

**LOS ANGELES COUNTY
DEPARTMENT OF PUBLIC WORKS**

HYDROLOGIC REPORT

1989 - 90

**PREPARED BY THE
HYDRAULIC/WATER CONSERVATION DIVISION
JUNE 1991**

TABLE OF CONTENTS

Credits 1
About This Report 2
Introduction 3
The Los Angeles County 4
Flood Control and Water Conservation 8

PRECIPITATION

General Discussion A1
Location Map of Rain Gages PA1
Active Rainfall Stations A3
Isohyetal Map PA2

EVAPORATION

General Discussions/Evaporation Station List B1
Summary of Monthly Evaporation Amounts at Selected Stations B2
Location Map of Evaporation Stations PB1

RUNOFF

General Discussion C1
Location Map of Streamflow Recording Stations PC1
Index of Stream Gaging Stations C3

Summary of Monthly Discharge Records at Selected Stations

STATION
NO.

STATION NAME

L1 - R LITTLE ROCK CREEK above Little Rock Dam C5

<u>STATION NO.</u>	<u>STATION NAME</u>	
F2B - R	BROWNS CREEK at Variel Avenue	C6
P3 - R	SAN GABRIEL West Fork above Forks	C7
P4B - R	SAN GABRIEL RIVER East Fork above Forks	C8
U7-R	FISH CREEK above Mouth of Canyon	C9
U8-R	SAN GABRIEL RIVER below Morris Dam	C10
F34D-R	LOS ANGELES RIVER below Firestone Boulevard	C11
F37B-R	COMPTON CREEK near Greenleaf Drive	C12
F38C-R	BALLONA CREEK above Sawtelle Boulevard	C13
F42B-R	SAN GABRIEL RIVER above Spring Street	C14
F45B-R	RIO HONDO above Stewart and Gray Road	C15
F53-R	DUME CREEK at Pacific Coast Highway	C16
F54B-R	TOPANGA CREEK above Mouth of Canyon	C17
F64-R	RIO HONDO above Mission Bridge	C18
F81D-R	ALHAMBRA WASH near Klingerman Street	C19
F82C-R	RUBIO WASH at Glendon Wash	C20
F83-R	MISSION CREEK at San Gabriel Boulevard	C21
F92-R	SANTA CLARA RIVER below Highway 5	C22
F122-R	PALLETT CREEK at Valyermo Highway	C23
F125-R	SANTIAGO CREEK above Little Rock Creek	C24
F130-R	MALIBU CREEK below Cold Creek	C25
F181-R	MONTEBELLO STORM DRAIN above Rio Hondo	C26
F190-R	SAN GABRIEL RIVER at Foothill Boulevard	C27

<u>STATION NO.</u>	<u>STATION NAME</u>	
F192B-R	RIO HONDO below Lower Azusa Road	C28
F193B-R	SANTA ANITA WASH at Longden Avenue	C29
F194B-R	SAWPIT WASH below Live Oak Avenue	C30
F250-R	SAN GABRIEL- AZUSA CONDUIT at 25 feet Weir below San Gabriel Dam	C31
F252-R	VERDUGO WASH at Estelle Avenue	C32
F261C-R	SAN GABRIEL RIVER below Valley Boulevard	C33
F262B-R	SAN GABRIEL RIVER above Florence Avenue	C34
F263C-R	SAN GABRIEL RIVER below San Gabriel River Parkway	C35
F267B-R	SIERRA MADRE WASH at Highland Oaks Avenue	C36
F274B-R	DALTON WASH at Merced Avenue	C37
F279C-R	LOS CERRITOS CHANNEL at Stearns Street	C38
F280-R	SANTA FE CHANNEL below Santa Fe Dam	C39
E285-R	BURBANK - WESTERN STORM DRAIN at Riverside Drive	C40
F300-R	LOS ANGELES RIVER at Tujunga Avenue	C41
F301-R	SAWTELLE - WESTWOOD CHANNEL above Culver Boulevard	C42
F304-R	WALNUT CREEK above Puente Avenue	C43
F312-R	SAN JOSE CHANNEL above Workman Mill Road	C44
F317-R	ARCADIA WASH below Grand Avenue	C45
F318-R	EATON WASH at Loftus Drive	C46
F319-R	LOS ANGELES RIVER below Wardlow Road	C47
F328-R	MINT CANYON CREEK at Fitch Avenue	C48

<u>STATION NO.</u>	<u>STATION NAME</u>	
F329-R	BRADBURY CHANNEL below Central Avenue	C49
F338-R	RUBIO DIVERSION CHANNEL below Gooseberry Canyon Inlet	C50
F342-R	BRANFORD STREET CHANNEL below Sharp Avenue	C51
F350-R	LIMEKILN CREEK above Aliso Creek	C52
F354-R	COYOTE CREEK below Spring Street	C53
F377-R	BOUQUET CANYON CREEK at Urbandale Avenue	C54
F378-R	DOMINGUEZ CHANNEL at Vermont Avenue	C55

RESERVOIR

General Discussion	D1
Location Map of District Reservoirs	PD1

Dam Operations Record

PACOIMA	D3
BIG TUJUNGA	D5
DEVIL'S GATE	D7
EATON WASH	D9
SANTA ANITA	D11
SAWPIT	D13
COGSWELL	D15
SAN GABRIEL	D17
BIG DALTON	D19
SAN DIMAS	D21

Dam Operations Record (Cont.)

PUDDINGSTONE DIVERSION	D23
PUDDINGSTONE	D25
LIVE OAK	D27
THOMPSON CREEK	D29

EROSION CONTROL

General Discussion	E1
Location Map of Debris Basins	PE1
Debris Basin-Design Data	E3
Debris Basin-Debris Production History	E7
Location Map of Major Burned Areas	PE2

WATER QUALITY

General Discussion	F1
Total Dissolved Solids at Selected Surface Stations	F5
Monthly Monitoring - Los Angeles River at Wardlow Road	F6

Groundwater Quality Well Locations

San Fernando Valley	PF1
San Gabriel Valley	PF2
Coastal Plain	PF3
Santa Clara Valley	PF4
Antelope Valley	PF5

Surface Water Quality Monitoring Locations

Monitor Group 1	PF6
-----------------------	-----

Surface Water Quality Monitoring Locations (Cont.)

Monitor Group 2 PF7

WATER CONSERVATION

General Discussion G1

Data on Spreading Facilities owned by the Department G9

Data on Spreading Facilities owned by Others G11

Water Conserved in all Department Facilities G12

Imported and Reclaimed Water Spread Amounts G13

Key Well Hydrographs (Listing and Locations) G14

Location Map G15

West Coast G16

Central Basin G16/17

Main San Gabriel G18/19

San Gabriel Canyon G19

Pomona G20

Claremont Heights G21

Raymond Basin G21

Santa Clara Valley G22

Antelope Valley G22/23

Main San Fernando G23/24

Location Map of Water Conservation Facilities PG1

Santa Clarita Valley Groundwater Basin PG2

Groundwater Contour Maps

San Fernando Valley (Upper Los Angeles River Area)	PG3
San Gabriel Valley	PG4
Coastal Plain	PG5
Santa Clarita Valley	PG6

This report was prepared in the Hydraulic/Water Conservation Division under the direction of Donald F. Nichols, Assistant Deputy Director. The following people contributed to the completion of this report:

General Supervision and Coordination

G. J. Pederson

Supervision

A. Gribnau
A. Bentley
T. Su

Coordination

J. Keith
G. Farag

Investigation and Computation

L. Amandy	H. Khachikian
R. Brown	J. Mitchell
D. Carpenter	M. Cheung
J. Doughly	S. Morrison
P. Gonda	G. Mundo
W. Ward	A. Rodriguez
F. Benson	K. Smith
P. Imaa	I. Wong
D. Potter	P. Wood

Graphic Design, Layout, Art Production

T. Conger
D. Sackley
R. Gist

ABOUT THIS REPORT

The 1989-90 Hydrologic Report represents a significant departure in terms of data content and format from reports published previously by the Department of Public Works and its predecessor, the Los Angeles County Flood Control District. The changes primarily entail the reporting of less detailed hydrologic data than were previously published, such as monthly and annual summaries instead of daily data. We apologize for any inconvenience this may cause our users.

With the rapid development of computing technology, there appears to be less demand for hydrologic data in written form, and it is our intention at some future time to phase out the published book reports and make the data available on computer diskettes. In the meantime, any user who desires more detailed information about any of the types of hydrologic data which we manage can write the Custodian of Hydrologic Records at:

**Los Angeles County Department of Public Works
Hydraulic/Water Conservation Division
P.O. Box 1460
Alhambra, CA 91802-1460**

or telephone: **(818) 458-6112**

INTRODUCTION

This report contains hydrologic data relative to Los Angeles County for the period beginning October 1, 1989 and ending September 30, 1990. The data are presented in seven sections.

Precipitation - lists 353 active rainfall stations and presents corresponding seasonal rainfall amounts.

Evaporation - lists all locations for which evaporation data is on file and provides monthly evaporation amounts at 14 locations.

Runoff - presents the maximum, minimum, and mean of the daily flow rates for each month and the monthly volumes for 50 streamflow stations.

Dam Operation - presents the maximum and minimum of the daily inflow and outflow rates for each month, the instantaneous peak inflow and outflow rates and storage volumes for 14 dams and reservoirs.

Erosion Control - lists debris basins and debris production amounts and displays maps of major watershed burns.

Water Quality Monitoring - presents maps of surface and groundwater sampling locations, and data at selected locations.

Conservation and Groundwater - presents records of water conserved at various facilities, water injected at seawater barrier projects, well hydrographs, and groundwater basins.

Where practical, data which would satisfy immediate needs and serve as useful reference are published in these reports. Several tables appear listing locations where unpublished data are available. Additional information may be obtained by writing to:

**Los Angeles County Department of Public Works
Hydraulic/Water Conservation Division
P.O. Box 1460
Alhambra, CA. 91802-1460**

or telephone: **(818) 458-6112**

LOS ANGELES COUNTY

TOPOGRAPHY

The County of Los Angeles covers an area of 4,083 square miles and measures approximately 66 miles in the east - west and 73 miles in the north - south directions.

The terrain within the County can be classified in broad terms as being 25 percent mountainous, 10 percent coastal plain; and 65 percent hills, valleys, or deserts. Relief of the terrain ranges from sea level to a maximum elevation of 10,000 feet. The coastal plain is generally of mild slope and contains relatively few depressions or natural ponding areas. The slopes of main river systems crossing the coastal plain, such as the San Gabriel River, Los Angeles River, and Ballona Creek, range from 4 to 14 feet per mile.

Topography in the mountainous area is generally rugged with deep, V-shaped canyons separated by sharp dividing ridges. Steepwalled canyons with side slopes of 70 percent or more are common. The gradient of principal canyons in the San Gabriel Mountains ranges from 150 to 850 feet per mile. Mountain ranges are aligned in a general east-west direction, the major range being the San Gabriel Mountains. The majority of mountain ridges lie below Elevation 5,000 feet, the total area above this level being approximately 210 square miles.

GEOLOGY - SOILS

Igneous, sedimentary, and metamorphic rock groups are all represented within the County. The San Gabriel Mountains and Verdugo Hills are composed primarily of highly fractured igneous rock, with large areas of granitic rock formation being exposed above soils which are coarse and porous. Faulting and deep weathering have produced porous zones in the rock formation; however, rock masses have produced a comparatively shallow soil mantle due to the steepness of slopes which accelerates erosion of the fine material.

LAND USE

The principal vegetative cover of upper mountain areas consists of various species of brush and shrubs known as chaparral. Most trees found on mountain slopes are oak, with alder, willow, and sycamore found along streambeds at lower elevations. Pine, cedar, and juniper are found in ravines at higher elevations and along high mountain summits.

The chaparral is extremely flammable, and extensive burns of the mountain vegetation frequently occur during dry, low-humidity weather accompanied by high winds. Chaparral has the ability to sprout following fire and grows rapidly to re-establish the watershed cover within a period of 5 to 10 years.

Grasses are the principal natural vegetation on the hills. Much of the hill land and nearly all of the valley land in the densely populated portion of the County south of the San Gabriel Mountains has been converted to urban and suburban use. Development of the Santa Clarita Valley and desert areas to the north of the San Gabriel Mountains is sparse at present but is proceeding at an accelerated rate.

Other mountains and hilly reaches within the Department are composed primarily of folded and faulted sedimentary rocks, including shale, sandstone, and conglomerate. Residual soils in these areas are shallow and are generally less pervious than those of the San Gabriel Mountain range.

Valley and desert soils are alluvial and vary from coarse sand and gravel near canyon mouths to silty clay and gravel or clay in lower valleys and the coastal plain. The alluvial fill has been built up by repeated deposition of debris to depths as great as 2,000 feet in places. This fill is quite porous in areas of relatively low clay content. Impervious layers and irregularities in the underlying bedrock divide the alluvium into several County groundwater basins. Valley soils are generally well drained and relatively few perched water or artesian areas are present.

CLIMATE

The climate within the County varies between subtropical on the Pacific Ocean side of the San Gabriel mountain range to arid in the Mojave Desert. Nearly all precipitation occurs during the months of December through March. Precipitation during summer months is infrequent, and rainless periods of several months are common. Snowfall at elevations above 5,000 feet is frequently experienced during the winter storms, but the snow melts rapidly except on higher peaks and the northern slopes. Snow is rarely experienced on the coastal plain.

January and July are the coldest and warmest months of the year, respectively. At Los Angeles, the 30-year average daily minimum temperature for January is 48 degrees above zero. The average daily maximum temperature for July is 84 degrees. At Mount Wilson (Elevation 5,850 feet), the 30-year average daily minimum temperature for January is 35 degrees above zero and the average daily maximum temperature for July is 80 degrees.

HYDROMETEOROLOGIC CHARACTERISTICS

Coastal and Mountain Areas

Precipitation in the Los Angeles area occurs primarily in the form of winter orographic rainfall associated with extratropical cyclones of North Pacific origin. Major storms consists of one or more frontal systems and occasionally last four days or longer. Air masses and frontal systems associated with major storms commonly extend for 500 to 1,000 miles in length and produce rainfall simultaneously throughout the County. Major storms approach Southern California from the west or southwest with southerly winds which continue until frontal passage. The mountain ranges lie directly across the path of the inflow of warm, moist air, and orographic effects cause precipitation to be greatly intensified.

The effect of snowmelt upon flood runoff is of significance in the few cases when warm spring rains from southerly storms fall on a snowpack. During major storms, temperatures throughout the County may remain above freezing.

Average individual storm rainfall amounts and intensities conform to a fairly definite aerial pattern which reflects general effects of topographic differences.

FLOOD CONTROL AND WATER CONSERVATION

FLOODS. . .AN OLD STORY

Floods in Los Angeles County have been recorded as far back as the days of the Mission Padres. For centuries waters have swept out of the San Gabriel Mountains causing extensive property damage and taking a great toll of lives.

Such a flood occurred in 1914 causing over \$10 million in property damage and taking many lives. As a result, the State legislature passed an act creating the Los Angeles County Flood Control District.

The Department was assigned two tasks. . .control the floods and conserve the water.

CONTROLLING THE WATERS

Successful early bond issues financed construction of the 14 dams which the Department built in the San Gabriel Mountains and foothills to impound storm waters until they could be released in an orderly fashion. Debris basins were constructed to trap eroded materials which had caused terrible damage in the past. Flood channel improvements were undertaken to confine the waters.

Department engineers prepared a Comprehensive Plan in the early 1930's which provided for the control of flooding and the saving of as much of the water as practicable.

Federal legislation in 1936 brought the United States Army Corps of Engineers into the local flood control picture. Since that time, the two agencies have been jointly pursuing construction of the Comprehensive Plan. The Department also cooperates with the United States Soil Conservation Service and Forestry Service in erosion control.

CONSERVING THE WATERS

In addition to its flood control program, the Department has the equally important task of conserving as much of the storm and other waste waters as practicable. The use of water conservation facilities in or adjacent to river channels and their tributaries permits water to be percolated into underground reservoirs for later pumping and supply to consumers. These water conservation facilities are located in areas where the underlying soils are composed of porous sands and gravel formations. Some resemble rice paddies, while others are deep basins which were once gravel pits.

The importance of this activity is apparent when it is realized that about 35 to 40 percent of the water used in the County is pumped from ground supplies. The growth of the County, combined with periodic droughts, seriously depleted these supplies on numerous occasions down through the years.

Other major conservation efforts by the Department include combatting the serious intrusion by salt water to underground fresh well supplies inland from the Pacific Ocean and the utilization of imported water and reclaimed sewage waters in spreading operations.

ORGANIZED TO DO THE JOB

Day-to-day administration of Department affairs is vested in the Director of Public Works who is appointed by and responsible to the Los Angeles County Board of Supervisors. A part of the Department's activities involve the planning, design and construction of flood control and water conservation facilities, and the operation and maintenance of dams, debris basins, spreading grounds, channels, and storm drains.

PRECIPITATION

PRECIPITATION

This section contains annual precipitation data collected by the Department for the period beginning October 1, 1989 and ending September 30, 1990. Although the Department operates and maintains 353 rainfall stations, including standard and automatic gages which record amounts for durations ranging from 5 minutes to 24 hours, only annual amounts for the report period are listed herein. Additional data can be obtained by contacting the custodian of hydrologic records at the location shown in the front of the report.

ALERT SYSTEM (AUTOMATIC LOCAL EVALUATION IN REAL TIME)

The Department of Public Works has installed a state-of-the-art ALERT computer system to monitor meteorological conditions in the County and Southern California in real time, i.e., as they occur. The system includes a network of field sensors that monitor precipitation amounts, river stages, and reservoir levels. The system can forecast peak flows in the Los Angeles, Rio Hondo, and San Gabriel Rivers.

During the report period, the Department has continued to install and expand its ALERT System. The Department's ALERT system is also now automatically receiving rainfall data from the Corps of Engineers' Los Angeles Telemetry System.

COOPERATION

The cooperation of observers in furnishing rainfall data to the Department as a public service is appreciated. The effort of the many agencies and individuals who have so freely cooperated with us in the collection of this data have resulted in the large number of complete records for the period covered by this report.

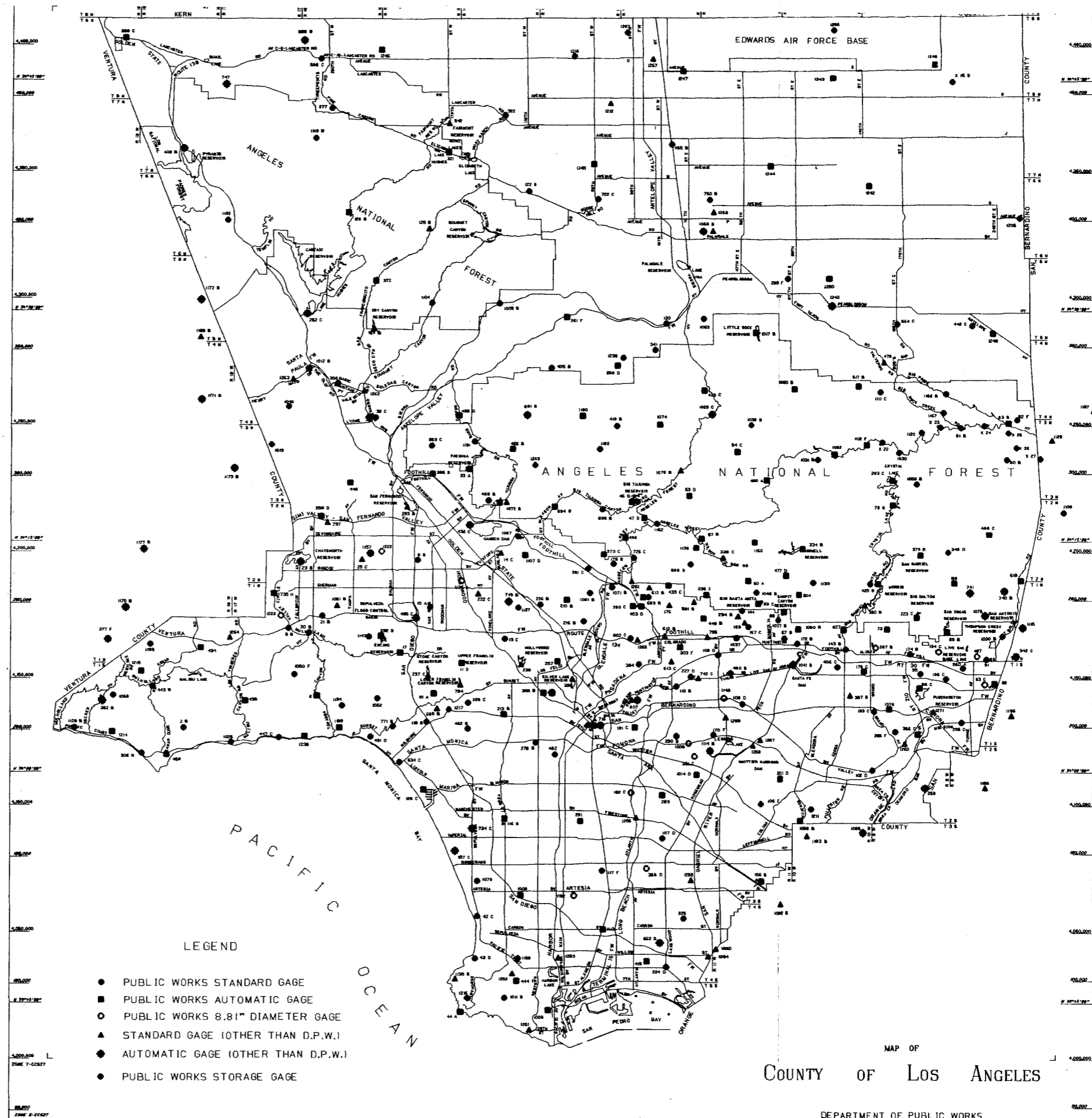

4,400,000
 4,350,000
 4,300,000
 4,250,000
 4,200,000
 4,150,000
 4,100,000
 4,050,000
 4,000,000
 3,950,000
 3,900,000
 3,850,000
 3,800,000
 3,750,000
 3,700,000
 3,650,000
 3,600,000
 3,550,000
 3,500,000
 3,450,000
 3,400,000
 3,350,000
 3,300,000
 3,250,000
 3,200,000
 3,150,000
 3,100,000
 3,050,000
 3,000,000
 2,950,000
 2,900,000
 2,850,000
 2,800,000
 2,750,000
 2,700,000
 2,650,000
 2,600,000
 2,550,000
 2,500,000
 2,450,000
 2,400,000
 2,350,000
 2,300,000
 2,250,000
 2,200,000
 2,150,000
 2,100,000
 2,050,000
 2,000,000
 1,950,000
 1,900,000
 1,850,000
 1,800,000
 1,750,000
 1,700,000
 1,650,000
 1,600,000
 1,550,000
 1,500,000
 1,450,000
 1,400,000
 1,350,000
 1,300,000
 1,250,000
 1,200,000
 1,150,000
 1,100,000
 1,050,000
 1,000,000
 950,000
 900,000
 850,000
 800,000
 750,000
 700,000
 650,000
 600,000
 550,000
 500,000
 450,000
 400,000
 350,000
 300,000
 250,000
 200,000
 150,000
 100,000
 50,000
 0
 -50,000
 -100,000
 -150,000
 -200,000
 -250,000
 -300,000
 -350,000
 -400,000
 -450,000
 -500,000
 -550,000
 -600,000
 -650,000
 -700,000
 -750,000
 -800,000
 -850,000
 -900,000
 -950,000
 -1,000,000

- LEGEND
- PUBLIC WORKS STANDARD GAGE
 - PUBLIC WORKS AUTOMATIC GAGE
 - PUBLIC WORKS 8.81" DIAMETER GAGE
 - ▲ STANDARD GAGE (OTHER THAN D.P.W.)
 - ◆ AUTOMATIC GAGE (OTHER THAN D.P.W.)
 - PUBLIC WORKS STORAGE GAGE

MAP OF
 COUNTY OF LOS ANGELES

DEPARTMENT OF PUBLIC WORKS
 RAINFALL STATION LOCATIONS

ACTIVE RAINFALL STATIONS 1989-1990

STATION NO.	STATION NAME	TYPE OF GAGE	THOMAS GUIDE PAGE	NORTH LATITUDE	WEST LONGITUDE	GAGE ELEV. (feet)	SEASONAL TOTAL (inches)
2B	ESCONDIDO CANYON	S	112 E3	34-02-55	118-46-25	1050	9.0*
5B	CALABASAS	S	100 F3	34-09-24	118-38-14	924	6.7
6	TOPANGA PATROL STATION	A	109 C5	34-05-03	118-35-57	745	12.4
9B	SEPULVEDA AND RAYEN	S	8 C6	34-13-52	118-28-04	828	7.5
10A	BEL AIR HOTEL	A	32 E5	34-05-11	118-26-45	540	9.7
11D	UPPER FRANKLIN CYN RES.	SP A	33 B1	34-07-10	118-24-35	867	8.6
13C	NORTH HOLLYWOOD-LAKESIDE	S	23 F4	34-08-46	118-21-13	550	7.8
14C	ROSCOE-MERRILL	S	9 F5	34-14-19	118-21-32	1050	7.3
15A	VAN NUYS	S	15 D6	34-10-48	118-27-03	695	8.5
17	SEPULVEDA CYN AT MULHOLLAND	A	22 A5	34-07-51	118-29-26	1425	11.2
20B	GIRARD RESERVOIR	S	13 B3	34-09-07	118-36-36	986	7.9
21B	WOODLAND HILLS	S	13 C1	34-10-14	118-35-33	875	7.4
23B	CHATSWORTH RESERVOIR	SP AP	6 A6	34-13-44	118-37-18	900	6.1
25C	NORTHRIDGE-L.A.D.W.P.	SP	7 B6	34-13-52	118-32-28	810	7.6
29F	GRANADA HILLS	S	7 D2	34-15-03	118-31-08	1035	N.R.
32C	NEWHALL-SOLEIDAD DIV. HDQTRS	S AP	127 C3	34-23-07	118-31-54	1243	7.7
33A	PACOIMA DAM	S A	128 F9	34-19-48	118-23-59	1500	9.8
42C	REDONDO BEACH-CITY HALL	S	67 D3	33-50-43	118-23-20	70	5.0
43D	PALOS VERDES ESTATES	S	72 C2	33-47-58	118-23-29	216	7.7
44A	POINT VICENTE LIGHTHOUSE	A	77 B3	33-44-30	118-24-38	125	5.4
46D	BIG TUJUNGA DAM	S A	M C2	34-17-40	118-11-14	2315	13.6
47D	CLEAR CREEK-CITY SCHOOL	A	M D3	34-16-38	118-10-12	3150	14.0*
53D	COLBY'S	A	M F2	34-18-05	118-06-39	3620	11.1
54C	LOOMIS RANCH-ALDER CREEK	S A	(197)	34-20-55	118-02-54	4325	9.1
57B	CAMP HI HILL (OPIDS)	A	M F3	34-15-18	118-05-41	4250	19.6*
60A	HOEGEE'S	A	20A D1	34-12-32	118-02-02	2412	N.R.
63C	SANTA ANITA DAM	S A	20A F2	34-11-03	118-01-12	1400	17.9
67G	MONROVIA-MOUNTAIN AVENUE	S	29 C4	34-08-46	117-59-05	602	11.3
68C	SAWPIT DAM	S A	20B C6	34-10-30	117-59-07	1375	16.3
73	GLENDORA-ENGLEWILD RANCH	A	87 C3	34-09-22	117-50-57	1165	13.2
78B	COLDBROOK RANGER STATION	A	P A2	34-17-26	117-50-26	3280	17.5*
80B	PRAIRIE FORKS	ST	P F1	34-20-20	117-41-30	5640	N.R.
81B	VINCENT GAP	ST	(200)	34-22-26	117-45-05	6590	N.R.
82F	TABLE MOUNTAIN	S	(201)	34-22-56	117-40-39	7420	10.9
83B	BIG PINES RECREATION PARK	A	(201)	34-22-44	117-41-20	6860	9.3
89B	SAN DIMAS DAM	S A	95A C3	34-09-10	117-46-17	1350	13.6
91	CLAREMONT-INDIAN HILL	S	91 B1	34-07-22	117-43-11	1403	12.3
92	CLAREMONT-POMONA COLLEGE	S A	91 C4	34-05-48	117-42-33	1185	12.4
93C	CLAREMONT-POLICE STATION	8.81	91 B4	34-05-45	117-43-18	1170	12.1
95	SAN DIMAS-FIRE WARDEN	S	89 F3	34-06-26	117-48-19	955	12.0

ACTIVE RAINFALL STATIONS 1989-1990

STATION NO.	STATION NAME	TYPE OF GAGE	THOMAS GUIDE PAGE	NORTH LATITUDE	WEST LONGITUDE	GAGE ELEV. (feet)	SEASONAL TOTAL (inches)
96C	PUDDINGSTONE DAM	S A	89 F4	34-05-31	117-48-24	1030	12.1
102D	WALNUT-N.I. INDUSTRIES	S	97 B2	34-00-11	117-52-10	500	14.3
106F	WHITTIER CITY YARD	S	55 D4	33-58-57	118-02-50	300	6.5
107D	DOWNEY-FIRE DEPARTMENT	S	60 A5	33-55-48	118-08-47	110	7.9
108D	EL MONTE FIRE STATION	S	38 D6	34-04-30	118-02-30	275	11.4
109D	WEST ARCADIA	S	28 A6	34-07-42	118-04-22	547	11.0
110B	ALHAMBRA	S	37 B3	34-05-40	118-07-41	533	11.5
116G	INGLEWOOD COURTHOUSE	A	57 A1	33-57-05	118-21-13		8.2
117F	COMPTON FIRE STATION	S	64 F3	33-53-42	118-13-34	78	N.R.
119G	SAWTELLE-SOLDIERS HOME	S	41 D2	34-03-21	118-27-20	345	11.1
120	VINCENT PATROL STATION	S	183 A9	34-29-17	118-08-27	3135	1.7*
122G	LEONA VALLEY-RACKETT RANCH	S	171 G3	34-37-52	118-19-22	3300	8.8
125B	SAN FRANCISQUITO CYN P.H. 1	SP	(169)	34-35-25	118-27-15	2105	9.9
126C	BOONE OLIVE PUMP PLANT	A	49 D4	33-58-58	118-27-33	30	5.0
127B	DRY CANYON RESERVOIR	SP	124 D1	34-28-55	118-31-32	1511	N.R.
128B	ELIZABETH LAKE	A	(168)	34-36-28	118-33-40	2075	10.6
134C	PUDDINGSTONE DIVERSION	8.81	95A C5	34-07-52	117-46-55	1160	13.7
143B	AZUSA-CITY PARK	S	86 D5	34-08-03	117-54-17	610	10.3*
144	SIERRA MADRE DAM	S	20A D3	34-10-34	118-02-32	1100	14.9
156B	LA MIRADA-STANDARD OIL CO.	A	83 A4	33-52-59	118-01-00	75	7.1
157C	EL SEGUNDO-CHEVRON OIL CO.	S AP	56 A6	33-54-57	118-25-05	150	3.2
158	TANBARK FLATS	A AP	P D5	34-12-20	117-45-40	2750	14.3
167C	ARCADIA PUMPING PLANT #1	S	28 E2	34-09-31	118-02-02	611	12.4
169	SIERRA MADRE PUMPING PLANT	SP	28 D2	34-09-47	118-02-21	700	13.6
170F	POTRERO HEIGHTS	S	47 A4	34-02-32	118-04-44	285	12.3
172B	DUARTE	S	29 E4	34-08-26	117-58-02	548	8.0
174B	GLENORA	S	87 E6	34-07-43	117-49-08	930	12.8
175B	LA CANADA IRRIGATION DIS.	S	19 A1	34-13-39	118-12-40	2020	12.8
176	ALTADENA-RUBIO CANYON	SP	20 B6	34-10-55	118-08-15	1125	13.7
178C	AZUSA VALLEY WATER CO.	A	88 F2	34-06-38	117-52-50	620	10.4
191C	L.A.C.D.P.W. WAREHOUSE	A	45 B1	34-03-48	118-11-58	400	8.7*
192C	BELL-FIRE STATION	8.81	53 C5	33-58-45	118-11-16	145	7.8*
193C	COVINA-NIGG	S	89 A5	34-04-55	117-52-25	575	12.0
196C	LA VERNE-FIRE STATION	S	90 D3	34-06-06	117-46-20	1050	11.7
200	SAUGUS-S. C. EDISON CO.	S	123 H8	34-25-21	118-34-26	1096	5.3
201D	HACIENDA HEIGHTS	A	85 C3	33-59-40	117-59-28	875	11.0
210B	BRAND PARK	A	18 B5	34-11-18	118-16-20	1250	10.5
213G	LOS ANGELES-HANCOCK PARK	A	42 F1	34-03-52	118-21-17	200	9.5
216B	GLENDALE-ANDREE	S	25 D2	34-09-54	118-15-01	615	9.0
222C	NORTH HOLLYWOOD P. P.	SP	16 C4	34-11-39	118-23-17	717	8.0

ACTIVE RAINFALL STATIONS 1989-1990

STATION NO.	STATION NAME	TYPE OF GAGE	THOMAS GUIDE PAGE	NORTH LATITUDE	WEST LONGITUDE	GAGE ELEV. (feet)	SEASONAL TOTAL (inches)
223C	BIG DALTON DAM	S A	87 F2	34-10-06	117-48-36	1587	16.0
224D	LONG BEACH-ALAMITOS LAND CO.	S	76 B3	34-47-	118-08-		5.5
225	MONTANA RANCH	S	71 C3	33-50-35	118-07-09	47	5.7
226B	BURBANK-FIRE STATION	S	17 E6	34-10-58	118-18-23	680	8.4
227D	SAN GABRIEL-BRUNGTON-ORTON	S	37 D2	34-06-18	118-06-32	472	11.8
228C	BEVERLY HILLS CITY HALL	S AP	33 C6	34-06-00	118-23-40		9.7*
235C	HENNIGER FLATS	A 8.81	20 F4	34-11-38	118-05-17	2550	15.8
237C	STONE CANYON RESERVOIR	SP	32 D2	34-06-21	118-27-13	865	10.8
238	HOLLYWOOD DAM	SP	34 C1	34-07-04	118-19-55	750	8.4
250D	ACTON CAMP	A	189 E5	34-27-02	118-11-55	2625	4.2
251C	LA CRESCENTA	S	18 D1	34-13-20	118-14-40	1440	12.4
252C	CASTAIC DAM	SP AP	(178)	34-29-53	118-36-53	1150	6.4
255F	MT. SAN ANTONIO COLLEGE	S	93 D4	34-02-41	117-50-19	720	9.3
256C	POMONA-FIRE STATION	S	94 E3	34-03-16	117-45-10	844	9.9
257	GRIFFITH PARK NURSERY	S	35 A1	34-07-18	118-17-04	850	8.9*
259D	CHATSWORTH-TWIN LAKES	S A	1A D6	34-16-43	118-35-41	1275	6.3
261F	ACTON-ESCONDIDO CANYON	A	181 H9	34-29-42	118-16-22	2960	4.1*
269D	DIAMOND BAR FIRE STATION	SP AP	97 F2	33-59-50	117-48-55	870	9.8
274B	ACTON-LEE	SP	182 B5	34-31-31	118-13-58	3490	N.R
277	SAWMILL MOUNTAIN	S	(155)	34-43-15	118-35-00	3700	9.6
278B	L.A. CLARK MEMORIAL LIBRARY	S	43 D5	34-02-00	118-18-46	203	7.9*
280C	FLINTRIDGE-SACRED HEART	A	19 D6	34-10-54	118-11-08	1600	11.8
283C	CRYSTAL LAKE-EAST PINE FLAT	A	P B1	34-19-02	117-50-28	5370	21.7
287B	GLENDORA-CITY HALL	8.81	87 B5	34-08-09	117-51-52	785	12.9
289	LAGUNA-BELL-S.C.E. CO.	SP	54 A5	33-58-37	118-08-48	140	9.7
290B	MONTEREY PARK-FIRE STATION	S	46 B4	34-02-27	118-07-42	305	10.0
291	LOS ANGELES-96th AND CENTRAL	A	58 C3	33-56-56	118-15-17	121	8.1
292D	ENCINO RESERVOIR	S A	21 D3	34-08-56	118-30-57	1075	8.6
293B	LAKE LOS ANGELES	SP	2 A4	34-17-18	118-28-54	1150	8.3
294B	SIERRA MADRE-MIRA MONTE P.P.	SP	28 C1	34-10-11	118-02-51	985	14.9
298C	GORMAN - SHERIFF	A	(141)	34-47-47	118-51-27	3835	4.0
299F	LITTLE ROCK - SCHWAB	S	184 F5	34-32-12	117-58-43	2800	2.9
303F	PASADENA - CALTECH	A	27 C5	34-08-14	118-07-25	800	11.7
304	SAWPIT CANYON-DEER PARK	A	20B E4	34-11-38	117-57-52	2690	19.5*
306H	ZUMA BEACH	S	111 F6	34-01-15	118-49-42	15	5.1
321	PINE CANYON PATROL STATION	A	157 D7	34-40-24	118-25-45	3286	8.9*
322	MUNZ VALLEY RANCH	S	158 A2	34-42-50	118-21-15	2600	4.2
334B	COGSWELL DAM	S A	N D4	34-14-37	117-57-35	2300	17.1
336	SILVER LAKE RESERVOIR	SP	35 B3	34-06-08	118-15-54	445	9.6
338C	MT. WILSON-OBSERVATORY	SP	20A C1	34-14-07	118-04-28	5709	19.7

ACTIVE RAINFALL STATIONS 1989-1990

STATION NO.	STATION NAME	TYPE OF GAGE	THOMAS GUIDE PAGE	NORTH LATITUDE	WEST LONGITUDE	GAGE ELEV. (feet)	SEASONAL TOTAL (inches)
341	ALISO CANYON-BLUM RANCH	S	189 J4	34-27-33	118-09-20	2900	INC.
342C	UPLAND-EUCLID PUMP PLANT	AP	96 E6	34-07-33	117-40-52	1610	11.5
348D	EAST FORK RANGER STATION	ST	P D4	34-14-20	117-46-09	2075	N.R.
352B	LECHUZA PATROL STATION	S AP	105 B6	34-04-38	118-52-47	1620	9.7
355B	LOS ANGELES CITY COLLEGE	S AP	34 F4	34-05-14	118-17-28	310	8.7*
356C	SPADRA-LANTERMAN HOSPITAL	S A	93 F4	34-02-31	117-48-35	690	9.6
363C	WILSON CANYON	ST	128 A7	34-21-17	118-27-00	3175	12.0*
372	SAN FRANCISQUITO P. H. NO.2	SP A	(179)	34-32-02	118-31-27	1580	10.7
373C	BRIGGS TERRACE	S A	11 F5	34-14-17	118-13-27	2200	13.4
377F	LAKE SHERWOOD ESTATES	SP AP	102A C4	34-08-26	118-52-31	960	10.3
379B	SAN GABRIEL-EAST FORK	A	P C4	34-14-09	117-48-18	1600	13.6
387B	COVINA CITY YARD	SP	88 E5	34-05-02	117-53-57	508	11.1
388D	PARAMOUNT-COUNTY FIRE DEPT.	8.81	65 E3	33-53-50	118-10-02	80	6.9*
390B	MORRIS DAM	SP	P A6	34-10-53	117-52-43	1210	12.9
391C	MONTEBELLO-FIRE DEPARTMENT	8.81	54 E1	34-01-08	118-06-15	250	10.8
394	HIGHLAND PARK	S	36 D1	34-07-06	118-10-39	620	10.2
395B	OLIVE VIEW SANITARIUM	A	2 D1	34-19-29	118-26-55	1425	10.9
402F	CEDAR SPRINGS	A	(199)	34-21-21	117-52-34	6780	17.8*
405B	SOLEDA CANYON	S	188 F6	34-26-23	118-17-33	2150	6.9
406C	WEST AZUSA	S	88 C2	34-06-53	117-54-56	505	10.7
409B	PYRAMID RESERVOIR	SP AP	(154)	34-40-34	118-46-47	2505	4.5
415	SIGNAL HILL-CITY HALL	S A	75 E2	33-47-49	118-10-03	140	5.8
419B	SANTA CLARA RIDGE-MT GLEASON	ST	(196)	34-22-36	118-12-23	5420	11.7*
423C	ANGELES FOREST-ALISO CYN	A	(190A)	34-24-57	118-05-26	3920	6.2*
425B	SAN GABRIEL DAM	S A	P A5	34-12-19	117-51-38	1481	15.4
433C	FAIR OAKS DEBRIS BASIN	A	20 B3	34-12-15	118-08-18	1585	9.3
434	AGOURA	A	100A A5	34-08-08	118-45-08	800	7.0
435	MONTE NIDO	A	108 A6	34-04-41	118-41-35	600	11.0
436C	HANSEN DAM	AP	9 C2	34-16-08	118-23-59	1110	8.8
442C	MESCAL CREEK	S	(194)	34-29-05	117-44-10	3570	4.4
443B	LATIGO CANYON-BEACH RANCH	S	106 B4	34-05-35	118-48-52	1700	12.0
444F	ROLLING HILLS-BOTANICAL GDNS	A	73 B4	33-47-00	118-20-35	400	6.3
446	ALISO CANYON-OAT MOUNTAIN	A	1 A2	34-18-53	118-33-25	2367	8.5
447C	CARBON CANYON	S	114 E4	34-02-18	118-38-56	50	4.7
449B	EATON WASH DAM	S A	27 E1	34-10-06	118-05-33	880	11.5
453D	DEVILS GATE DAM	A	19 D6	34-10-53	118-10-27	980	INC.
455B	LANCASTER-HWY MAINTENANCE	S	160 B6	34-40-57	118-08-02	2395	1.9
458	ZUMA CANYON PATROL STATION	A	112 C6	34-01-10	118-47-46	115	6.8
462B	HILLCREST COUNTRY CLUB	S	42 B3	34-02-54	118-24-06	185	9.4
465C	SEPULVEDA DAM	AP	22 B1	34-10-06	118-28-11	683	7.8

ACTIVE RAINFALL STATIONS 1989-1990

STATION NO.	STATION NAME	TYPE OF GAGE	THOMAS GUIDE PAGE	NORTH LATITUDE	WEST LONGITUDE	GAGE ELEV. (feet)	SEASONAL TOTAL (inches)
466B	PACOIMA CANYON-DUTCH LOUIE	A	(195)	34-21-07	118-20-38	3220	10.7
477D	SANTA ANITA-SPRING CAMP	A	20B C2	34-12-52	117-58-56	4655	19.6*
478	VALYERMO-U.S.F.S.	SP	192 H5	34-26-44	117-51-10	3710	INC.
480B	TEMPLE CITY FIRE STATION	S	38 C2	34-06-31	118-03-25	404	12.0
482	LOS ANGELES-U.S.C.	S	43 F6	34-01-14	118-17-15	208	7.5*
486C	WALKER RANCH	A	P E3	34-15-30	117-42-57	3720	14.7*
488B	KAGEL CANYON PATROL STATION	S	3 E4	34-17-45	118-22-30	1450	9.5
491D	PACIFIC PALISADES	S	40 C4	34-02-22	118-31-43	293	6.8
492A	CHILAO-HWY MAINTENANCE STA.	A	N C1	34-19-05	118-00-30	5275	12.3*
493D	SAND CANYON-MACMILLAN RANCH	A	128 D3	34-23-17	118-24-50	1805	12.7*
497	CLAREMONT-SLAUGHTER	8.81	91 A1	34-07-35	117-43-55	1350	12.8
498	DARK CYN-ANGELES CREST HWY	A	M C3	34-15-21	118-11-45	2800	16.2
517B	LEWIS RANCH	A	(192A)	34-25-12	117-53-11	4615	5.0
542	FAIRMONT	SP	(145)	34-42-15	118-25-40	3050	7.2
560A	LA VERNE HEIGHTS	S	90 E2	34-06-48	117-45-02	1210	12.5
564C	LLANO	S	185 J9	34-29-13	117-50-02	3390	2.6
588D	MT. LOWE	ST	20 D1	34-13-37	118-06-33	4435	N.R.
591B	SANTA ANITA RESERVOIR	SP	20 E5	34-11-08	118-06-16	1205	14.1
598C	NEENACH-ERSTAD	S	(143)	34-46-28	118-35-55	3062	2.7
598D	NEENACH-CHECK 43-D.W.R.	SP	(143)	34-47-40	118-37-15	2965	2.8
610B	PASADENA-CITY HALL	SP	27 A4	34-08-54	118-08-36	864	11.6
612B	PASADENA-CHLORINE PLANT	SP	19 E3	34-12-04	118-09-49	1160	13.7
613C	PASADENA FIRE STATION	SP	27 B5	34-07-15	118-08-05	779	11.4
619	SAN ANTONIO CYN-SIERRA P. H.	A	P F5	34-12-29	117-40-26	3110	16.3
627	SAN GABRIEL CANYON-P. H.	SP A	86 D3	34-09-20	117-54-28	744	12.9
634C	SANTA MONICA	S	49 A1	34-00-43	118-29-27	94	5.8
662D	LONG BEACH AIRPORT	SP	71 A6	33-49-	118-09-	34	6.1
680B	WESTWOOD (U.C.L.A.)	SP	41 E1	34-04-10	118-26-30	430	10.2
683B	SUNSET RIDGE	S A	19 E4	34-12-53	118-08-47	2110	13.4
694G	BIG TUJUNGA CANYON-CAMP 15	A	M D6	34-17-22	118-17-17	1525	8.2
695B	TUJUNGA CANYON-VOGEL FLAT	S	M B2	34-17-12	118-13-32	1850	15.9
716	LOS ANGELES-DUCOMMUN ST.	SP A AP	44 E3	34-03-09	118-14-13	306	8.3
722C	BELLEVIEW	S	171 B3	34-37-23	118-13-55	2880	4.1*
726C	ANGELES CREST GUARD STATION	S	M D4	34-14-01	118-11-04	2300	16.4
734C	L. A. INTERNATIONAL AIRPORT	SP AP	56 C3	33-56-25	118-23-44	105	5.8
735H	BELL CANYON	A	5 D4	34-11-40	118-39-23	895	6.7*
740B	SAN DIMAS CANYON-FERN NO.2	AP	P F6	34-11-48	117-41-45	5200	15.3*
741	SAN DIMAS CYN	AP	P E6	34-11-41	117-44-26	2675	14.7*
742C	SAN GABRIEL FIRE DEPARTMENT	SP	37 E3	34-06-11	118-05-56	445	11.3*
747	SANDBERG-AIRWAYS STATION	SP AP	(142)	34-44-47	118-43-29	4517	2.2

ACTIVE RAINFALL STATIONS 1989-1990

STATION NO.	STATION NAME	TYPE OF GAGE	THOMAS GUIDE PAGE	NORTH LATITUDE	WEST LONGITUDE	GAGE ELEV. (feet)	SEASONAL TOTAL (inches)
749B	BURBANK VALLEY PUMP PLANT	SP AP	17 A5	34-11-11	118-20-54	655	8.2
750B	PALMDALE GEGIONAL AIRPORT	S	172 F6	34-37-20	118-05-00	2528	2.6
771B	PACIFIC PALISADES-RIVIERA	S	40 F3	34-03-03	118-29-58	315	10.1*
794	LOWER FRANKLIN RESERVOIR	SP	33 B4	34-05-43	118-24-40	585	8.1
795	PASADENA	SP	27 F4	34-08-52	118-05-14		12.5
797	DE SOTO RESERVOIR	SP	6 D1	34-16-17	118-35-12	1127	8.5
801B	MAGIC MOUNTAIN	AP	(195)	34-23-18	118-19-27	4720	13.8
802C	EAGLE ROCK RESERVOIR	SP	26 C4	34-08-47	118-11-20	970	9.1
807	ASCOT RESERVOIR	SP AP	36 C5	34-04-46	118-11-14	620	10.2
1005B	MINT CANYON FIRE STATION	S	(180)	34-30-35	118-21-40	2300	4.8
1006	SAN PEDRO-CITY RESERVOIR	SP A	78 F2	33-44-37	118-17-47	150	5.6
1008	LA FRESA-S.C.E.CO.	S A	63 C6	33-52-07	118-19-55	65	5.7
1011B	PALOS VERDES FIRE STATION	S	78 A1	33-45-25	118-21-11	1275	6.1
1012B	CASTAIC JUNCTION	S A	123 E6	34-26-18	118-36-43	1005	4.7
1014F	RIO HONDO SPREADING GROUNDS	A	54 E3	33-59-57	118-06-04	170	8.7
1017B	LITTLE ROCK CREEK ABOVE DAM	A	(191)	34-28-41	118-01-24	3280	3.8
1019	SANTA SUSANA MTS-SALT CYN	ST	126 A6	34-21-24	118-39-42	2850	8.5*
1020B	PADUA HILLS PATROL STATION	S	96 D4	34-08-52	117-41-55	1800	13.4
1025	MALIBU BEACH-DUNNE	S	113 E5	34-02-00	118-42-42	160	7.2
1029C	TUJUNGA-MILL CREEK SUMMIT	S AP	(197)	34-23-22	118-04-49	4990	7.8
1030	MOUNT ISLIP	ST	(200)	34-20-50	117-49-57	7520	21.7*
1031B	MOUNT WATERMAN	ST	(199)	34-20-23	117-56-21	7960	N.R.
1037	ARCADIA-ARBORETUM	S	28 C4	34-08-48	118-02-59	565	11.6
1038B	PACIFICO MOUNTAIN	ST	(198)	34-22-40	118-01-44	6880	N.R.
1040	POTRERO CYN-SUNRAY OIL CO.	S	126 C2	34-23-50	118-38-18	1150	7.1
1041B	SANTA FE DAM	AP	39 D1	34-07-04	117-58-24	427	9.4
1046B	SANTA ANITA CYN-CHANTRY FLAT	S	20A F1	34-11-46	118-01-20	2175	20.8
1050F	OLD TOPANGA CANYON	S	108 F3	34-06-24	118-37-43	1000	10.5*
1051B	CANOGA PARK-PIERCE COLLEGE	SP	12 E5	34-10-51	118-34-23	800	7.6
1052	CAMP JOSEPHO	S	30 D5	34-04-51	118-31-10	660	13.1*
1058B	PALMDALE	SP AP	172 E7	34-35-17	118-05-31	2595	2.3
1059B	SOUTH MT. HAWKINS	ST	P B1	34-18-46	117-48-32	7700	18.0*
1060B	LITTLE ROCK-SYCAMORE CAMP	A	(191)	34-25-02	117-58-13	4000	6.3*
1062	BUCKHORN FLAT	A	(199)	34-20-44	117-55-08	6760	15.9*
1063	SOLEDAD PASS	S	183 E9	34-29-35	118-05-28	3520	3.7*
1068	RATTLESNAKE CANYON	S	105 C5	34-05-00	118-51-55	1290	13.3
1070	MANHATTAN BEACH	S	62 D4	33-53-00	118-23-19	182	5.3
1071B	DESCANSO GARDENS	S	19 B2	34-12-07	118-12-46	1325	11.6
1072B	LITTLE TUJUNGA RANGER STA.	SP A	3 F5	34-17-37	118-21-38	1275	10.6
1074	LITTLE GLEASON	A	(197)	34-22-43	118-08-57	5600	11.0*

ACTIVE RAINFALL STATIONS 1989-1990

STATION NO.	STATION NAME	TYPE OF GAGE	THOMAS GUIDE PAGE	NORTH LATITUDE	WEST LONGITUDE	GAGE ELEV. (feet)	SEASONAL TOTAL (inches)
1075	UPPER WOLFSKILL	AP	96 B2	34-10-13	117-43-16	3625	15.1*
1076B	MONTE CRISTO RANGER STATION	SP	M E1	34-19-42	118-07-20	3360	10.7
1077B	MONROVIA-FIVE POINTS	S	29 B1	34-09-58	117-59-37	962	14.4
1078	COVINA	A	93 C1	34-04-10	117-50-47	975	9.8*
1080B	BRADBURY DEBRIS BASIN	A	29 E3	34-09-23	117-57-58	935	13.0*
1081B	GLENDALE-GREGG	SP	18 D4	34-11-45	118-14-30	1350	12.6
1087	GREEN-VERDUGO PUMPING PLANT	S	10 B3	34-15-25	118-20-11	1340	8.2
1088B	LA HABRA HEIGHTS	S A	84 E2	33-56-55	117-57-51	445	9.8
1090	LOS ALAMITOS	SP	81 B6	33-48-35	118-04-35	25	5.7*
1092B	BUENA PARK	3" P	OC10 C1	33-51-28	117-59-29	80	N.R.
1095	ORANGE COUNTY RESERVOIR	SP AP	OC 2 F4	33-56-07	117-52-58	660	10.1
1104	BOUQUET CANYON AT TEXAS CYN	S	(180)	34-30-35	118-27-00	1760	6.0*
1107D	LA TUNA DEBRIS BASIN	A	10 C5	34-14-13	118-19-37	1160	8.7
1109	MT. BALDY	ST	S.B.CO.	34-16-53	117-37-00	8650	16.3*
1111C	DEVILS PUNCHBOWL	S	(192A)	34-24-48	117-51-25	4760	6.9
1113	DOMINGUEZ WATER CO.	A	69 F4	33-49-54	118-13-30	30	5.6
1114B	WHITTIER NARROWS DAM	AP	47 A6	34-01-29	118-05-02	239	10.0
1115	SAN ANTONIO DAM	AP SP	96 F3	34-09-24	117-40-20	2120	14.1
1119B	ATMORE MEADOW	ST	(155)	34-41-18	118-36-16	4325	10.0*
1120	DAWSON SADDLE	ST	(200)	34-22-08	117-48-10	7900	18.0*
1126A	LOS ANGELES-EAST VALLEY	8.81	16 B3	34-12-30	118-24-35	780	7.1*
1127	WEST BURBANK	S	17 B6	34-10-47	118-20-07	615	8.1*
1128	WRIGHTWOOD FIRE DEPARTMENT	SP	S.B.CO.	34-21-34	117-37-57	5960	9.9
1129B	NICHOLAS CANYON	S	110 D3	34-02-52	118-54-57	340	6.7
1132	OAK FLAT GUARD STATION	S	(166)	34-35-56	118-43-15	2800	9.8
1135B	LUNADA BAY	SP	72 A4	33-46-37	118-25-01	250	5.3*
1138	MOUNT DISAPPOINTMENT	A	M F4	34-14-42	118-06-07	5725	19.3*
1140	ROSEMEAD	8.81	38 B5	34-04-53	118-03-55	305	10.4
1147	EL CABALLERO COUNTRY CLUB	S	21 C4	34-08-52	118-31-53	1000	7.5
1152	CLEAR CREEK RANGER STATION	S	M D3	34-16-15	118-09-11	3625	13.1
1157	CAL STATE UNIV. NORTHRIDGE	SP AP	7 C5	34-14-17	118-31-48	890	8.2*
1158	TORRANCE MUNICIPAL AIRPORT	S	73 B2	33-47-59	118-20-08	102	6.3
1160	SAN GABRIEL CYN-WEST FORK	A	N B4	34-15-02	118-01-30	3200	20.6*
1162	IRON MOUNTAIN	ST	(196)	34-21-06	118-13-46	5320	15.4*
1166B	MILE HIGH RANCH	S	(193)	34-24-40	117-46-15	5280	7.8*
1167	FENNER CANYON	S	(200)	34-23-25	117-46-27	5380	12.0*
1169B	PIRU-TEMESCAL GUARD STATION	SP	V.CO.	34-28-22	118-45-21	1150	9.7
1170B	THOUSAND OAKS WEATHER STA.	AP	V.CO.	34-10-44	118-51-01	805	6.6
1171B	CAMULOS RANCH	SP AP	V.CO.	34-24-22	118-45-21	725	6.7
1172B	PIRU CANYON ABOVE PIRU LAKE	AP	(177)	34-30-48	118-45-24	1120	6.9

ACTIVE RAINFALL STATIONS 1989-1990

STATION NO.	STATION NAME	TYPE OF GAGE	THOMAS GUIDE PAGE	NORTH LATITUDE	WEST LONGITUDE	GAGE ELEV. (feet)	SEASONAL TOTAL (inches)
1173B	TAPO CANYON	AP	V.CO.	34-19-54	118-42-39	1525	8.6
1177B	BARD RESERVOIR	AP	V.CO.	34-14-32	118-49-41	1010	7.1
1183B	LA HABRA FIRE STATION	3"P	84 F4	33-55-53	117-57-17	315	N.R.
1190	PACOIMA CYN-NORTH FORK	S A	(195)	34-23-17	118-15-06	4180	13.0
1191	BEAR DIVIDE	S	128 F6	34-21-35	118-23-37	2700	11.8
1192	CARSON FIRE STATION	8.81	64 C6	33-52-04	118-15-45	92	5.0
1193	WESTLAKE VILLAGE	S	102 A5	34-08-19	118-49-05	885	6.9
1194	SANTA YNEZ RESERVOIR	S	109 F6	34-04-23	118-33-59	735	11.0*
1195	CHINO FIRE STATION NO. 2	SP	S.B.CO.	33-59-00	117-43-20	655	7.5
1196	MONTCLAIR FIRE DEPARTMENT	SP	95 E2	34-03-41	117-41-16	965	11.2
1197	CAJON WEST SUMMIT	SP	S.B.CO.	34-23-30	117-34-35	4838	N.R.
1198	PHELAN FIRE CONTROL	SP	S.B.CO.	34-25-30	117-34-00	4160	1.9*
1199	CLOUDCROFT DEBRIS BASIN	A	115 F3	34-02-58	118-34-12	350	6.6*
1203	LITTLE TUJUNGA-ALDER CREEK	ST	(195)	34-20-03	118-18-50	2625	N.R.
1205	MOODY SPRING	ST	(176)	34-36-04	117-40-23	2915	1.6
1206	MUROC	ST	(138)	34-48-26	117-55-03	2310	N.R.
1207	ROSAMOND	ST	147 F1	34-48-14	118-11-35	2340	1.5*
1209	SAN JOSE CHANNEL	8.81	47 F4	34-01-55	118-06-39	275	8.6
1210	NEENACH	ST	146 H4	34-46-42	118-15-48	2413	1.7*
1211	HACIENDA GOLF CLUB	S	98A A1	33-57-40	117-56-57	750	10.9
1212	LANCASTER FSS/FAA	SP	147 C9	34-44-00	118-13-00	2340	1.7
1214	ENCINAL CANYON-FIRE STATION	A	111 B4	34-02-52	118-52-07	175	7.0*
1215	SANTA MONICA MTS-KILPATRICK	A	105 F4	34-06-45	118-49-52	1775	12.3*
1216	RANCHO PALOS VERDES	S	77 C1	33-45-10	118-23-32	780	5.3*
1217	LOS ANGELES COUNTRY CLUB	S	42 A1	34-04-10	118-25-17	380	9.9*
1222	NORTHRIDGE-GARLAND	8.81	7 E3	34-14-	118-30-		8.7
1223	WOODLAND HILLS-SHERMAN	8.81	100 E1	34-10-06	118-38-57	1035	6.6
1225	REDONDO BEACH-LACDPW YARD	S	67 D1	33-51-	118-23-		N.R
1238	ACTON-MEARNS	S	189 G2	34-27-05	118-12-50		4.1*
1239	MALIBU-BIG ROCK MESA	A	115 A4	34-02-34	118-37-16	725	7.2*
1240	PEARBLOSSOM-CALIF.D.W.R.	SP AP	185 B7	34-30-32	117-55-15	3050	2.8
1242	ROCKY BUTTES	A	(162)	34-39-00	117-51-48	2540	1.7*
1243	REDMAN	A	(150)	34-45-52	117-55-30	2360	1.4*
1244	LANCASTER-ROPER	A	161 C6	34-40-27	118-00-37	2450	1.9*
1245	QUARTZ HILL-HALL	A	159 B7	34-40-28	118-14-40	2395	2.8
1246	SCOTT RANCH	A	(145)	34-46-59	118-28-10	2710	3.0*
1247	NORTH LANCASTER	A	148 D6	34-45-41	118-07-30	2310	INC.
1248	MESCAL-SMITH	A	(194)	34-28-03	117-42-40	3810	2.8
1249	RELAY	A	(150)	34-45-43	117-47-55	3140	1.3*
1250	AVEK	A	185 B5	34-32-21	117-55-23	2825	2.7*

ACTIVE RAINFALL STATIONS 1989-1990

STATION NO.	STATION NAME	TYPE OF GAGE	THOMAS GUIDE PAGE	NORTH LATITUDE	WEST LONGITUDE	GAGE ELEV. (feet)	SEASONAL TOTAL (inches)
1251	PALOS VERDES-WHITES POINT	SP	78 D6	33-42-50	118-19-02	100	5.4
1252	PALOS VERDES LANDFILL	SP	73 A4	33-45-40	118-20-03	400	5.9
1253	CARSON-COUNTY SANITATION	SP	74 A2	33-48-07	118-16-58	40	5.9
1254	LONG BEACH RECLAMATION PLANT	SP	76 F1	33-48-11	118-05-20	20	6.2
1255	LOS COYOTES RECLAMATION	SP	66 E4	33-53-05	118-06-24	70	7.0
1256	SOUTH GATE TRANSFER STATION	SP	59 E3	33-56-40	118-09-56	100	6.6
1257	SAN JOSE CREEK RECLAMATION	SP	47 F4	34-01-55	118-01-16	275	8.9
1258	PUENTE HILLS LANDFILL	SP	47 E5	34-01-35	118-01-49	300	9.1
1259	WHITTIER NARROWS RECLAMATION	SP	47 B1	34-03-59	118-03-54	225	10.2
1260	SPADRA LANDFILL	SP	93 E4	34-02-36	117-49-50	700	10.4
1261	LA CANADA RECLAMATION PLANT	SP	19 D2	34-13-00	118-11-14	1800	9.7
1262	SAUGUS RECLAMATION PLANT	SP	124 B9	34-24-48	118-32-23	1150	5.8
1263	VALENCIA RECLAMATION PLANT	SP	123 D7	34-25-55	118-37-13	1000	5.0
1264	CALABASAS LANDFILL	SP	100A E3	34-08-25	118-42-35	800	6.9
1265	SCHOLL CANYON LANDFILL	SP	26 C4	34-08-38	118-11-07	1000	10.1
1266	MISSION CANYON LANDFILL	SP	22 B6	34-08-40	118-28-45	1150	8.1
1267	LANCASTER RECLAMATION PLANT	SP	147 H4	34-46-38	118-09-11	2302	1.5
1268	PALMDALE RECLAMATION PLANT	SP	172 G6	34-35-30	118-05-10	2565	1.3
1271	POMONA WASTE RECLAMATION	SP	94 B3	34-03-18	117-47-34		9.1
X15D	HI VISTA	S	(151)	34-44-31	117-46-43	3087	1.3*
X22	ISLIP SADDLE	ST	(199)	34-21-27	117-51-05	6680	18.1*
X23	DORR CANYON	ST	(200)	34-22-16	117-46-51	7280	17.0*
X24	GRASSY HOLLOW	ST	(201)	34-22-30	117-43-05	7360	15.0*
X25	BEAR GULCH	ST	(201)	34-21-58	117-41-27	7880	11.5*
X26	BLUE RIDGE CAMP	ST	(201)	34-20-57	117-40-23	8450	11.0*
X27	GUFFY'S CAMP	ST	(201)	34-20-20	117-38-55	8080	11.5*

LEGEND:

- S Standard 8 inch diameter non-recording gage owned by the Department of Public Works
- 8.81 8.81 inch diameter non-recording gage owned by the Department of Public Works
- A Automatic recording gage owned by the Department of Public Works
- ST Storage type gage owned by the Department of Public Works
- SP Standard 8 inch diameter non-recording gage owned by outside interest
- AP Automatic recording gage owned by outside interest
- () Thomas Guide future page
- O.CO. Orange County Thomas Guide page
- V.CO. Ventura County Thomas Guide page
- S.B.CO. San Bernardino County Thomas Guide page
- DSC. Discontinued
- INC. Incomplete records
- * Estimated Seasonal Total

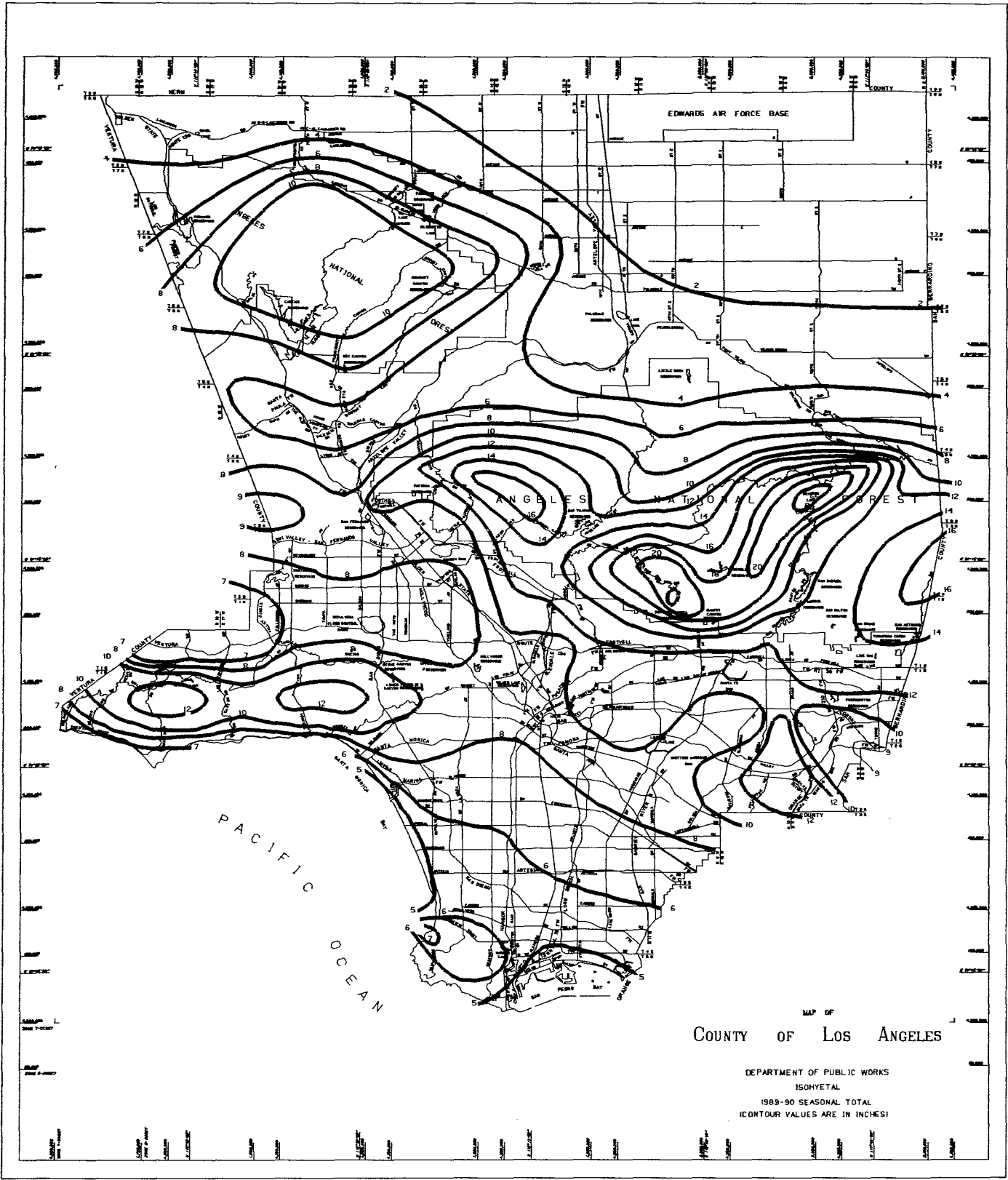

MAP OF
 COUNTY OF LOS ANGELES

DEPARTMENT OF PUBLIC WORKS
 ISOHYETAL
 1989-90 SEASONAL TOTAL
 (CONTOUR VALUES ARE IN INCHES)

EVAPORATION

EVAPORATION

Data for 14 active evaporation stations were reported to the Department during the 1989-90 water year. Daily records of active and inactive Department stations, as well as some stations of other agencies, are available in the Department's files. Monthly and seasonal evaporation has been published in the Department's Annual or Biennial Reports on Hydrologic Data since the 1931-32 season.

COOPERATION

The Department receives evaporation data from The Metropolitan Water District, Palmdale Water District, California Department of Water Resources, and Descanso Gardens.

LENGTH OF RECORD

The first land pan installed by this Department was at Santa Anita Dam in March of 1929. There are 30 evaporation stations which have records of 15 seasons or more in the Department's files.

EVAPORATION STATION LIST 1989 - 90

STA. NO.	STATION NAME	EQUIPMENT	ELEVATION OF PAN	THOMAS GUIDE	NORTH LATITUDE	WEST LONGITUDE
33 A	Pacoima Dam	24X36 S	1500 ft.	145 F9	34-19-48	118-23-59
46 D	Big Tujunga Dam	24X36 S	2315 ft.	F C2	34-17-40	118-11-14
63 C3	Santa Anita Dam	24X36 S	1400 ft.	99 F2	34-11-03	118-01-12
89 B	San Dimas Dam	24X36 S	1350 ft.	95A C3	34-09-10	117-46-17
96 C	Puddingstone Dam	24X36 S	1030 ft.	89 F4	34-05-31	117-48-24
223 B	Big Dalton Dam	24X36 S	1587 ft.	87 F1	34-10-06	117-48-36
252 C	Castaic Reservoir	48X10 S	1150 ft.	(178)	34-29-53	118-36-53
334 B	Cogswell Dam	24X36 S	2300 ft.	G D4	34-14-37	117-57-35
390 B	Morris Dam	72X36 US	1210 ft.	86 F1	34-10-53	117-52-43
409 B	Pyramid Reservoir	48X10 S	2505 ft.	(154)	34-40-34	118-46-47
425 B	San Gabriel Dam	24X36 S	1481 ft.	H A5	34-12-19	117-51-38
1014 F	Rio Hondo S. G.	24X36 S	170 ft.	54 D3	33-59-57	118-06-04
1058 B	Palmdale	24X36 S	2595 ft.	172 F7	34-35-17	118-05-31
1071 B	Descanso Gardens	24X36 S	1325 ft.	19 B3	34-12-07	118-12-46

LEGEND

- 24X36 S** = Screened land pan, 24 inches in diameter by 36 inches deep.
48X10 S = Screened land pan, 48 inches in diameter by 10 inches deep.
72X36 US = Unscreened land pan, 72 inches in diameter by 36 inches deep.
() = Thomas Guide future page assignment.

MONTHLY EVAPORATION SUMMARY FOR WATER YEAR 1989-90 (inches)

STA. NO	STATION NAME	OCT.	NOV.	DEC.	JAN.	FEB.	MAR.	APR.	MAY	JUN.	JUL.	AUG.	SEP.	TOTAL
33	A Pacoima Dam	7.99	9.41	8.39	6.35	5.12	5.30	4.76	6.90	9.75	10.22	8.48	9.49	92.14
46	D Big Tujunga Dam	8.17	6.61	6.25	4.04	6.59	5.44	5.84	7.80	9.72	12.29	10.04	10.59	93.36
63	D Santa Anita Dam	4.59	4.79	4.29	3.03	2.79	3.04	2.93	4.19	5.09	7.06	5.86	6.06	53.69
89	B San Dimas Dam	3.98	2.93	2.44	1.82	1.77	2.55	3.34	5.31	6.81	8.76	7.10	6.29	53.07
96	C Puddingstone Dam	5.06	4.20	3.37	2.70	3.59	4.14	4.65	7.23	8.96	10.90	9.36	8.46	72.61
223	B Dig Dalton Dam	4.17	3.32	2.54	2.44	2.26	2.84	3.18	5.44	7.13	10.15	7.93	8.41	52.65
252	C Castaic Reservoir	6.05	5.55	4.61	3.41	3.05	3.00	4.24	6.09	8.35	9.25	6.39	10.98	70.97
334	B Cogswell Dam	4.16	2.56	1.90	1.61	1.33	2.56	3.20	5.58	7.20	9.39	7.95	6.40	53.81
390	B Morris Dam	6.67	5.89	4.92	3.70	3.49	4.87	5.41	7.61	10.20	12.61	10.09	9.79	85.26
409	B Pyramid Reservoir	5.55	4.80	4.01	2.89	2.17	3.45	4.84	6.25	9.78	10.08	8.78	8.12	70.72
425	B San Gabriel Dam	6.31	5.35	4.37	3.20	3.38	4.10	5.07	6.41	8.59	10.48	8.74	8.22	74.18
1014	F Rio Hondo S.G.	3.92	3.14	2.56	1.63	2.50	2.86	4.03	5.66	4.18	7.44	7.05	6.37	51.32
1058	B Palmdale	3.98	2.69	1.48	1.71	1.77	3.90	4.66	6.15	8.92	9.78	7.36	INC	INC
1071	B Descanso Gardens	3.70	2.61	1.99	1.69	1.87	2.54	2.59	4.65	6.31	7.78	6.29	6.59	48.59



RUNOFF

RUNOFF

The Department operated or received data from 81 water-stage recording stations during the 1989-90 water year. Data from 51 of those stations are summarized and published in this volume.

RECORDS OF STREAMFLOW

Records published give the following information:

1. Station description which presents location, drainage area, type of channel, control, regulations, diversions, and available records.
2. Discharge tabulation which summarizes the maximum, minimum, and mean of the daily flow rates in second-feet for each month and the total monthly volumes in acre-feet.

ALERT SYSTEM (AUTOMATIC LOCAL EVALUATION IN REAL TIME)

The Department of Public Works has installed a state-of-the-art ALERT computer system to monitor meteorological conditions at 27 locations in the County. The system includes a network of field sensors that monitor precipitation amounts, river stages, and reservoir levels, and which forecast peak flows in the Los Angeles and San Gabriel Rivers and the Rio Hondo Channel.

During the report period, the Department has continued to install and expand its ALERT System. The Department's ALERT system is also now automatically receiving rainfall data from the Corps of Engineers' Los Angeles Telemetry System.

COOPERATION

The Department receives streamflow data from other agencies, or has access to the records for local stations. Data from 7 of the Department's stations are published in the United States Geological Survey's annual water supply papers.

Agencies with which the Department exchanges data are:

United States Geological Survey, Water Resources Division
United States Corps of Engineers
State Department of Water Resources
The Metropolitan Water District
San Gabriel River Water Committee

LEGEND

Stations are designated by letters and numbers which indicate ownership, operation agency, and type of station. The letters used have the following connotations:

Prefix F - Indicates a station owned and operated by the Los Angeles County Department of Public Works.

Prefix E - Indicates a station owned and operated by the Corps of Engineers, Department of the Army but operated and maintained by the United States Geological Survey.

Prefix U - Indicates a station originally constructed and operated by the United States Geological Survey, Water Resources Division, now operated by the Department.

Prefix P - Indicates a station owned and operated by the Department, formerly operated by the Pasadena Water Department.

Prefix L - Indicates a station owned and operated by the Department, formerly operated in cooperation with the Little Rock - Palmdale Irrigation District.

Suffix R - Indicates a recorder station.

Suffix B - Indicates that the station has been moved. B represents second location, C a third location, etc.

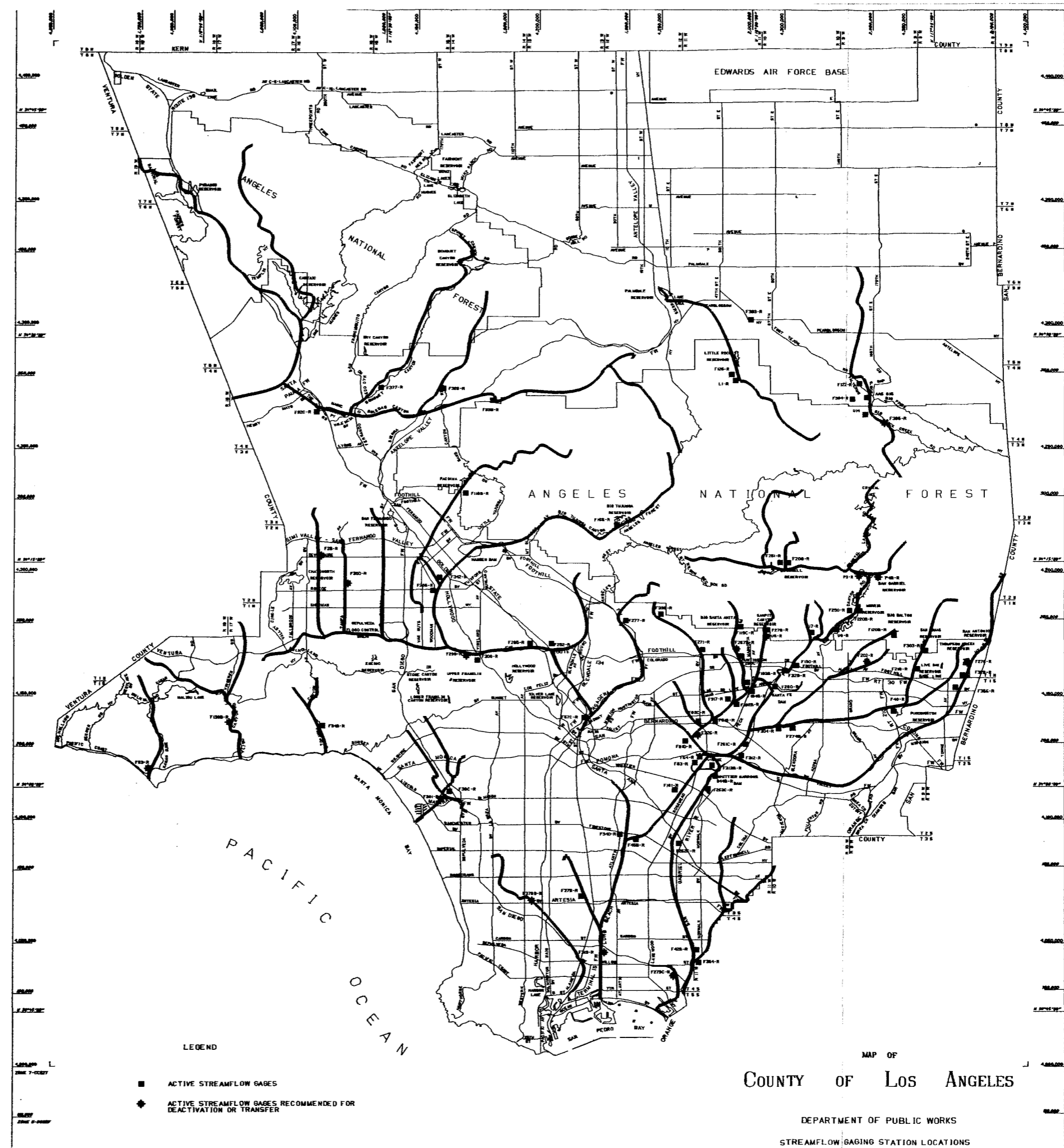

LEGEND

- ACTIVE STREAMFLOW GAGES
- ◆ ACTIVE STREAMFLOW GAGES RECOMMENDED FOR DEACTIVATION OR TRANSFER

MAP OF
COUNTY OF LOS ANGELES

DEPARTMENT OF PUBLIC WORKS
STREAMFLOW GAGING STATION LOCATIONS

INDEX OF STREAM GAGING STATIONS

STATION	NAME	THOMAS GUIDE PG.	ALERT NO.	REGU- LATED	DRAINAGE AREA *
L1-R	LITTLE ROCK CREEK ABOVE LITTLE ROCK DAM	J		NO	49.20
F2B-R	BROWNS CREEK AT VARIEL AVENUE	6 / D - 2		NO	13.50
P3-R	SAN GABRIEL RIVER - WEST FORKS ABOVE FORKS	P / A - 4		YES	102.00
P4B-R	SAN GABRIEL - EAST FORK	P / D - 4		NO	88.20
U5-R	SAWPIT CREEK BELOW MONROVIA CREEK	29 / C - 1		YES	5.30
U7-R	FISH CREEK ABOVE MOUTH OF CANYON	86 / B - 2		NO	6.36
U8-R	SAN GABRIEL RIVER BELOW MORRIS DAM	86 / F - 1	415	YES	212.40
U14-R	BIG ROCK CREEK ABOVE MOUTH OF CANYON	J		NO	23.00
AA5(015)	VALYERMO S. G., BIG ROCK CK. D/S VALYERMO RD.	192 / H - 5			
F32B-R	THOMPSON CREEK BELOW THOMPSON CREEK DAM	96 / C - 5	433	YES	3.70
F34D-R	LOS ANGELES RIVER BELOW FIRESTONE BLVD.	59 / E - 3	315	YES	596.00
F37B-R	COMPTON CREEK NEAR GREENLEAF DRIVE	64 / F - 4		NO	22.60
F38C-R	BALLONA CREEK ABOVE SAWTELLE BLVD.	50 / B - 3	369	YES	88.60
F40-R	PUDDINGSTONE CREEK BELOW PUDDINGSTONE DAM	89 / F - 4	427	YES	33.20
F42B-R	SAN GABRIEL RIVER ABOVE SPRING STREET	76 / F - 1	435	YES	231.00
F45B-R	RIO HONDO ABOVE STUART AND GRAY ROAD	59 / E - 3	307	YES	140.00
F53-R	DUME CREEK AT PACIFIC COAST HIGHWAY	110 / B - 4		NO	8.80
F54B-R	TOPANGA CREEK ABOVE MOUTH OF CANYON	109 / C - 4		NO	18.00
F64-R	RIO HONDO ABOVE MISSION BRIDGE	47 / B - 5		YES	115.00
F81D-R	ALHAMBRA WASH NEAR KLINGERMAN STREET	46 / F - 2	347	NO	15.20
F82C-R	RUBIO WASH AT GLENDON WAY	38 / A - 6	353	YES	10.90
F92C-R	SANTA CLARA RIVER AT OLD ROAD BRIDGE	123 / G - 7		YES	410.40
F93B-R	SANTA CLARA RIVER AT LANG RAILROAD BRIDGE	125 / J - 7		NO	157.30
F118B-R	PACOIMA CREEK FLUME BELOW PACOIMA DAM	3 / C - 1	330	YES	28.20
F119C-R	SANTA ANITA CREEK BELOW SANTA ANITA DAM	20A / F - 2	345	YES	10.80
F120B-R	BIG DALTON CREEK BELOW BIG DALTON DAM	87 / F - 2	418	YES	4.80
F122-R	PALLET CREEK AT VALYERMO HIGHWAY	199 / G - 4		NO	15.80
F125-R	SANTIAGO CREEK ABOVE LITTLE ROCK CREEK	J		NO	11.20
F130B-R	MALIBU CREEK BELOW COLD CREEK	107 / F - 6		YES	104.96
F168-R	BIG TUJUNGA CREEK BELOW BIG TUJUNGA DAM	M / C - 2	333	YES	82.30
F181-R	MONTEBELLO STORM DRAIN OUTLET TO RIO HONDO	54 / E - 3		NO	9.60
F190-R	SAN GABRIEL RIVER AT FOOTHILL BLVD.	86 / A - 5		YES	230.00
F192B-R	RIO HONDO BELOW LOWER AZUSA ROAD	38 / E - 4		YES	40.90
F193B-R	SANTA ANITA WASH AT LONGEN AVENUE	38 / F - 1		YES	18.80
F194B-R	SAWPIT WASH BELOW LIVE OAK AVENUE	39 / A - 2		YES	16.10
F202-R	BIG DALTON CREEK AT SIERRA MADRE AVENUE	87 / D - 4		YES	11.00
F209-R	SAN GABRIEL RIVER - W. FORK BELOW COGSWELL DAM	N / D - 4	410	YES	41.00
F218-R	SAN DIMAS WASH BELOW PUDD. DIVERSION DAM	95A / C - 5	424	YES	19.90
F220B-R	SAN GABRIEL - AZUSA CONDUIT 10FT WEIR BELOW DAM	P / A - 5		YES	0.00
F250-R	SAN GABRIEL - AZUSA CONDUIT 25FT WEIR BELOW DAM	P / A - 5		YES	202.70
F251-R	SAN GABRIEL W. FORK AT TOE OF COGSWELL DAM	N / D - 4		YES	39.20
F252-R	VERDUGO WASH AT ESTELLE AVENUE	25 / B - 3		YES	26.80
F260C-R	SANTA ANITA WASH BELOW FOOTHILL BLVD.	28 / E - 3		YES	17.20
F261C-R	SAN GABRIEL RIVER BELOW VALLEY BLVD.	48 / A - 2	351	YES	118.00
F262B-R	SAN GABRIEL RIVER ABOVE FLORENCE AVENUE	60 / E - 4		YES	215.80
F263C-R	SAN GABRIEL RIVER BELOW S. G. RIVER PKWY	55 / C - 1		YES	206.30
F267B-R	SIERRA MADRE WASH AT HIGHLAND OAKS AVENUE	28 / E - 3		YES	3.80
F271-R	EATON WASH BELOW EATON WASH DAM	27 / F - 1	342	YES	12.40
F274B-R	DALTON WASH AT MERCED AVENUE	48 / F - 1		YES	35.95
F276-R	THOMPSON CREEK S. G. INTAKE AT TSN CREEK	96 / C - 5		YES	3.70

INDEX OF STREAM GAGING STATIONS

STATION	NAME	THOMAS GUIDE PG.	ALERT NO.	REGU- LATED	DRAINAGE AREA *
F277-R	ARROYO SECO BELOW DEVILS GATE DAM	19 / D - 5	336	YES	32.50
F278-R	SAWPIT CREEK BELOW SAWPIT DAM	29 / C - 1	339	YES	3.30
F279C-R	LOS CERRITOS CHANNEL AT STEARNS STREET	76 / E - 3		NO	25.60
F280-R	SANTA FE DIVERSION CHANNEL BELOW SANTA FE DAM	39 / D - 2		YES	CONTROLLED
F285-R	URBANK WESTERN STORM DRAIN AT RIVERSIDE DR.	24 / E - 2		YES	25.00
F299-R	LOS ANGELES RIVER AT RADFORD	23 / C - 4			
F300-R	LOS ANGELES RIVER AT TUJUNGA AVE.	23 / D - 4		YES	401.00
F301-R	SAWTELLE-WESTWOOD CHANNEL ABOVE CULVER BLVD	50 / A - 3		YES	22.96
F303-R	SAN DIMAS CREEK BELOW SAN DIMAS DAM	95A / C - 3	421	YES	16.20
F304-R	WALNUT CREEK ABOVE PUENTE AVENUE	48 / D - 1		YES	57.60
F305-R	PACOIMA DIVERSION AT BRANFORD STREET	9 / A - 5		YES	48.80
F312-R	SAN JOSE CHANNEL ABOVE WORKMAN MILL ROAD	47 / F - 5	324	YES	83.40
F313B-R	RIO HONDO BYPASS CHANNEL ABOVE WHITTIER NAR.	47 / B - 5		YES	CONTROLLED
F317-R	ARCADIA WASH BELOW GRAND AVENUE	38 / E - 3	355	YES	8.50
F318-R	EATON WASH AT LOFTUS DRIVE	34 / C - 6		YES	22.80
F319-R	LOS ANGELES RIVER BELOW WARDLOW RIVER RD.	70 / B - 5	313	YES	815.00
E326-R	RIO HONDO BELOW GARVEY AVENUE	47 / B - 2		YES	91.20
F328-R	MINT CANYON CREEK AT FITCH AVENUE	125 / C - 5		NO	26.90
F329-R	BRADBURY CHANNEL BELOW CENTRAL AVENUE	29 / F - 5		YES	3.30
F338-R	RUBIO DIV. CHANNEL BEL. GOOSEBERRY CYN INLET	20 / C - 4		YES	2.10
F342-R	BRANFORD STREET CHANNEL BELOW SHARP AVE.	9 / B - 5		YES	5.01
F350-R	LIMEKILN CREEK ABOVE ALISO CREEK	7 / B - 6		YES	10.30
F354-R	COYOTE CREEK BELOW SPRING STREET	76 / F - 1	437	YES	185.00
F356-R	LIVE OAK CREEK BELOW LIVE OAK DAM	95A / F - 6	430	YES	2.28
F377-R	BOUQUET CANYON CREEK AT URBANDALE AVENUE	124 / F - 5		YES	51.90
F378D-R	DOMINGUEZ CHANNEL AT VERMONT AVENUE	63 / F - 5		NO	37.10
F393-R	LITTLE ROCK AT HIGHWAY 138	184 / D - 6		YES	70.00
F394-R	BIG ROCK CREEK UPSTREAM FROM PALLETT CREEK	192 / J - 4		NO	34.30
F395-R	MESCAL CREEK AT MOUTH	J		NO	5.71
G44B-R	SAN GABRIEL RIVER ABOVE WHITTIER NAR. DAM	47 / C - 6		NO	

* NOTE: All drainage areas in square miles.

LITTLE ROCK CREEK

above Little Rock Dam

STATION NO. L1-R

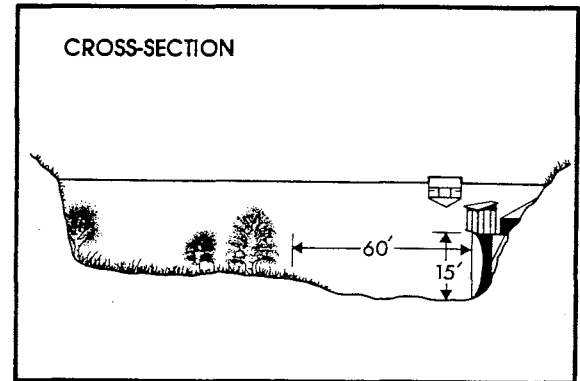
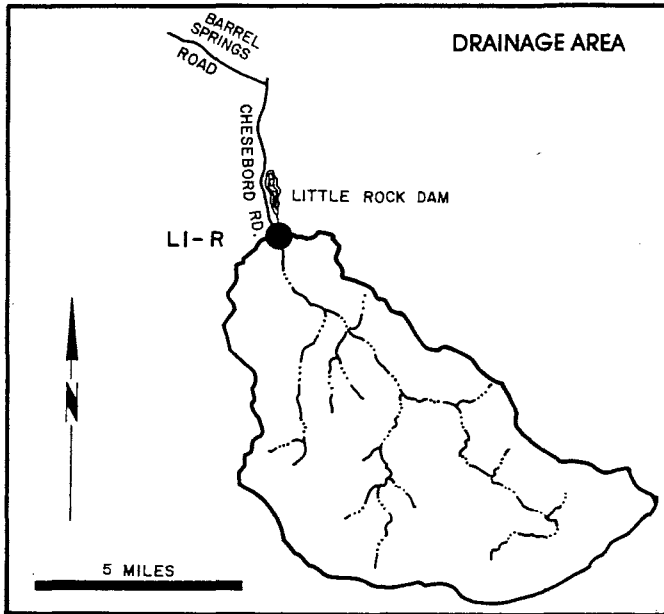
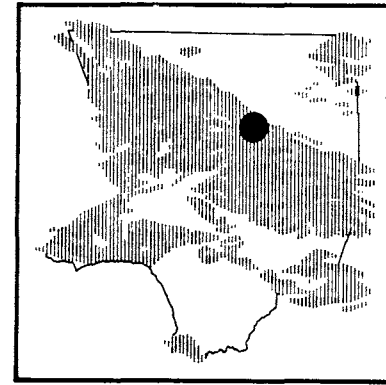

RECORDER- continuous water stage.
 METHOD OF MEASUREMENTS- wading or from cable car.
 DRAINAGE AREA- 49.2 square miles.
 LOCATION- 2.0 miles above Little Rock Dam, 5.0 miles south of Little Rock.
 REGULATION- none.
 CHANNEL- sand, gravel, and boulders, natural in section.
 CONTROL- channel forms control.
 LENGTH OF RECORD- October 1, 1930 to date.

WATER YEAR 1989 - 90
 (DISCHARGE IN SEC.-FT.)

STATION NO. : L1-R

DRAINAGE AREA : 49.20 SQ. MI.

		OCTOBER	NOVEMBER	DECEMBER	JANUARY	FEBRUARY	MARCH	APRIL	MAY	JUNE	JULY	AUGUST	SEPTEMBER
WATER YEAR 89-90	MEAN	0.0	0.0	0.3	10.1	5.4	7.6	4.2	2.4	1.5	0.0	0.0	0.0
	MAX.	0.0	0.1	2.0	40.3	11.4	13.2	5.9	3.6	2.5	0.0	0.0	0.0
	MIN.	0.0	0.0	0.0	0.6	2.2	4.2	3.0	2.1	0.0	0.0	0.0	0.0
TOTAL AF		0.0	0.2	17.7	623.0	302.0	468.0	247.0	145.0	86.9	0.0	0.0	0.0

BROWNS CREEK at Variel Avenue STATION NO. F2B-R

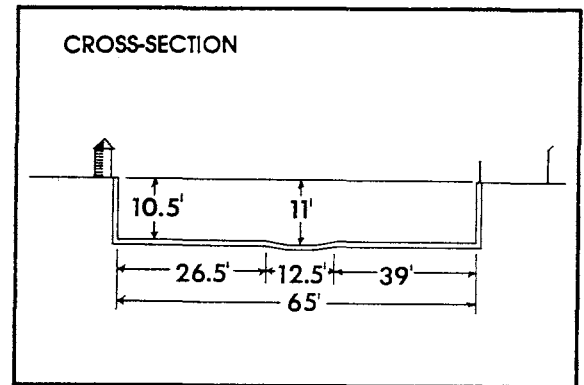
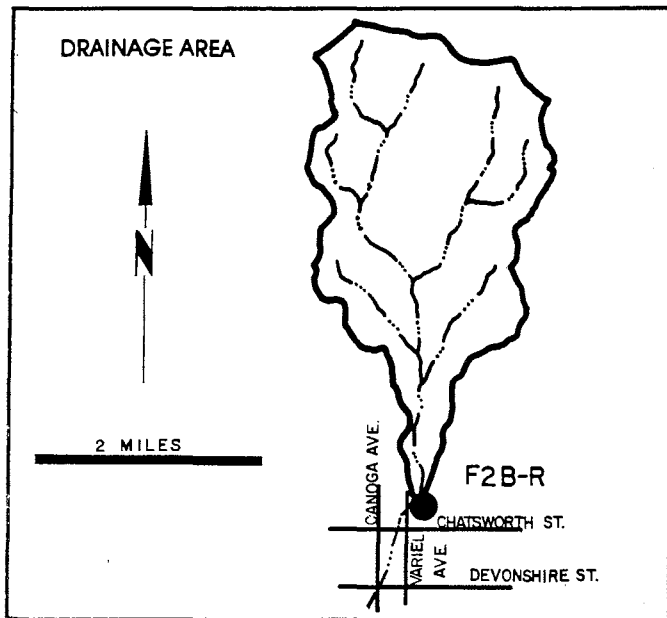
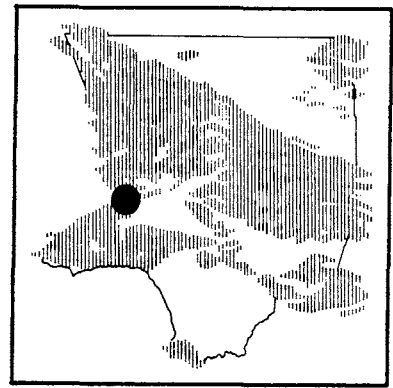

RECORDER- continuous water stage.
 METHOD OF MEASUREMENTS- wading.
 DRAINAGE AREA- 13.5 square miles.
 LOCATION- 100.0 feet upstream from Variel Avenue, 1.0 mile northeast of Chatsworth.
 REGULATION- none.
 CHANNEL- sand and gravel with pipe and wire revetments, temporarily improved section.
 CONTROL- concrete stabilizer.
 LENGTH OF RECORD- at Station F2-R, December 11, 1928, to August 27, 1932 and October 2, 1935, to October 31, 1939. at Station F2B-R, October 12, 1961, to date.

WATER YEAR 1989 - 90 (DISCHARGE IN SEC.-FT.)

STATION NO. : F2B-R

DRAINAGE AREA : 13.50 SQ. MI.

		OCTOBER	NOVEMBER	DECEMBER	JANUARY	FEBRUARY	MARCH	APRIL	MAY	JUNE	JULY	AUGUST	SEPTEMBER
WATER YEAR 89-90	MEAN	0.0	0.0	0.0	0.1	0.8	0.3	0.0	0.0	0.1	0.1	0.0	0.0
	MAX.	0.2	0.2	0.0	1.4	11.0	0.4	0.2	0.1	0.3	1.7	0.5	0.1
	MIN.	0.0	0.0	0.0	0.0	0.0	0.3	0.0	0.0	0.0	0.0	0.0	0.0
TOTAL AF		0.8	1.2	0.0	5.2	43.0	19.6	1.8	0.6	4.0	9.1	2.2	0.2

SAN GABRIEL RIVER

West Fork above Forks

STATION NO. P3-R

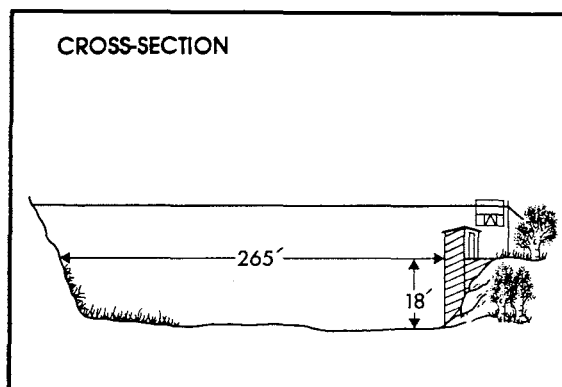
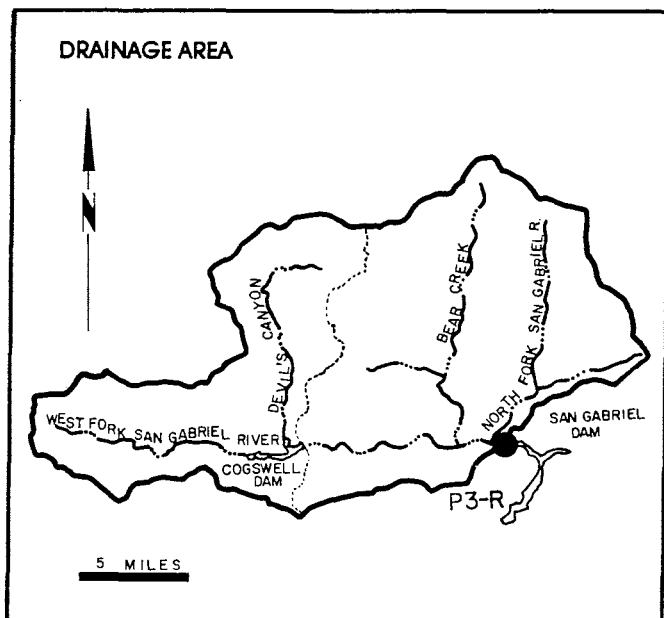
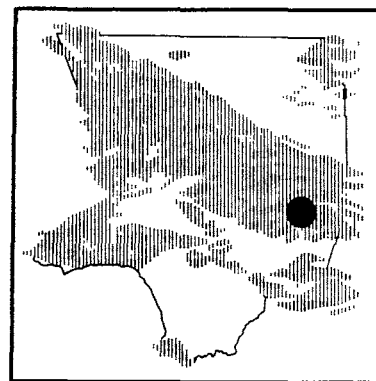

RECORDER- continuous water stage.

METHOD OF MEASUREMENTS- wading or from cable car.

DRAINAGE AREA- 102.0 square miles.

LOCATION- 1.5 miles above confluence with East Fork.

REGULATION- partially regulated by Cogswell Dam.

CHANNEL- natural, sand, gravel, and boulders.

CONTROL- subject to shifts in natural bottom.

LENGTH OF RECORD- at Station P3-R, December 3, 1930 to July 12, 1938 and September 27, 1938 to date. at Station P3B-R, July 12, 1938, to September 27, 1938.

REMARKS- for records prior to December 3, 1930 refer to Station P1-R.

WATER YEAR 1989 - 90
(DISCHARGE IN SEC.-FT.)

STATION NO. : P3-R

DRAINAGE AREA : 102.00 SQ. MI.

		OCTOBER	NOVEMBER	DECEMBER	JANUARY	FEBRUARY	MARCH	APRIL	MAY	JUNE	JULY	AUGUST	SEPTEMBER
WATER YEAR 89-90	MEAN	6.9	7.7	6.4	16.4	23.7	19.7	23.0	11.6	7.0	4.9	4.5	3.2
	MAX.	15.9	13.7	7.0	94.4	104.0	24.5	40.4	18.1	11.5	5.9	6.0	4.5
	MIN.	3.3	6.1	5.6	6.6	8.4	16.2	16.3	7.9	3.3	3.3	3.5	2.3
TOTAL AF		425.0	456.0	396.0	1005.0	1316.0	1209.0	1371.0	711.0	419.0	300.0	278.0	192.0

SAN GABRIEL RIVER

East Fork above Forks

STATION NO. P4B-R

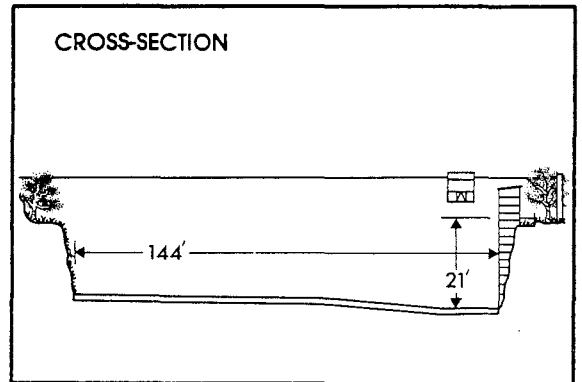
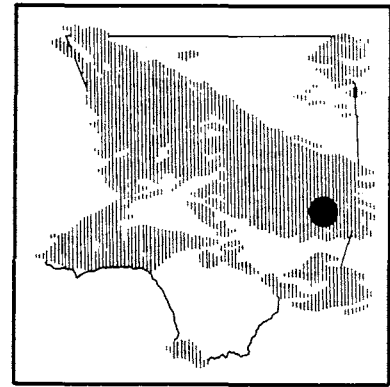
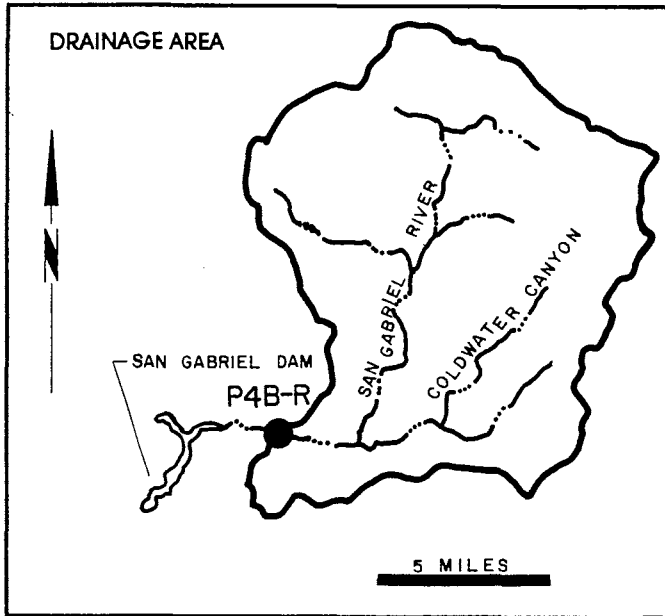

RECORDER- continuous water stage.
 METHOD OF MEASUREMENTS- wading or from cable car.
 DRAINAGE AREA- 88.2 square miles.
 LOCATION- 2.5 miles above the West Fork, 12.0 miles north of Azusa.
 REGULATION- none.
 CHANNEL- sand, gravel, and boulders, natural section.
 CONTROL- concrete, stabilizer with a 20-foot-wide low flow notch (constructed in November 1947).
 LENGTH OF RECORD- at Station P4-R, November 30, 1932 to December 10, 1938. at Station P4B-R, December 10, 1938 to date.
 REMARKS- the control height was increased 2.0 feet in September, 1955.

WATER YEAR 1989 - 90 (DISCHARGE IN SEC.-FT.)

STATION NO. : P4B-R

DRAINAGE AREA : 88.20 SQ. MI.

		OCTOBER	NOVEMBER	DECEMBER	JANUARY	FEBRUARY	MARCH	APRIL	MAY	JUNE	JULY	AUGUST	SEPTEMBER
WATER YEAR 89-90	MEAN	6.6	8.7	6.6	21.0	31.5	29.2	37.5	21.2	14.2	6.8	5.0	4.8
	MAX.	14.3	12.0	8.4	139.0	151.0	53.3	56.1	38.7	18.9	15.4	5.6	6.6
	MIN.	0.7	5.5	4.7	6.5	8.4	12.2	25.4	10.1	5.7	2.3	3.9	3.4
TOTAL AF		408.0	516.0	408.0	1293.0	1750.0	1798.0	2229.0	1305.0	843.0	416.0	305.0	284.0

FISH CREEK

above Mouth of Canyon
STATION NO. U7-R

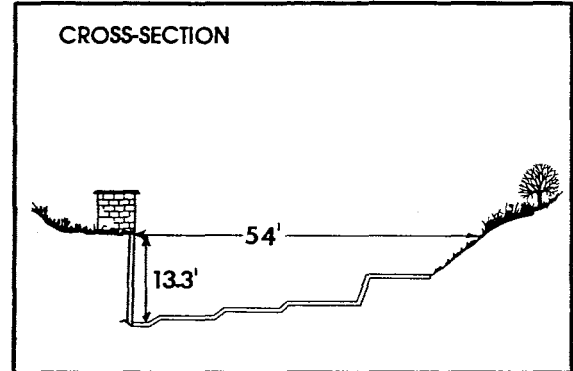
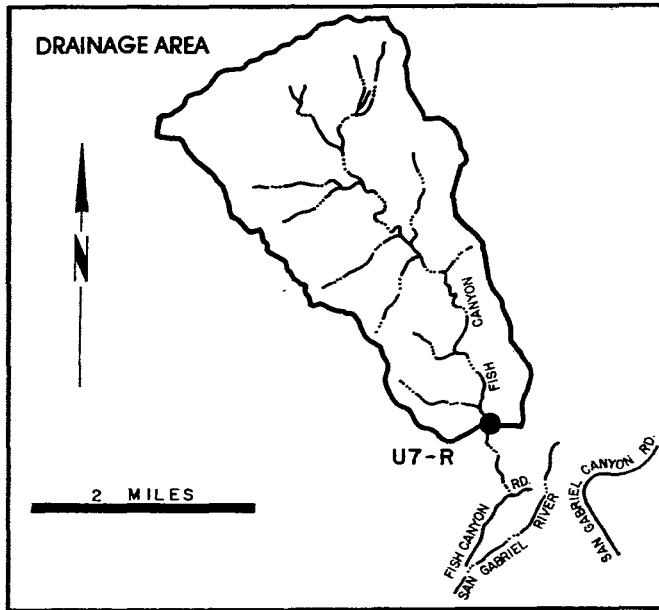
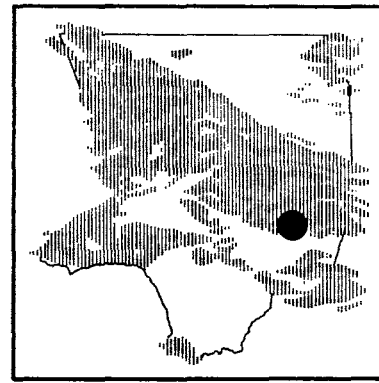

RECORDER- continuous water stage.
 METHOD OF MEASUREMENTS- wading.
 DRAINAGE AREA- 6.36 square miles.
 LOCATION - 0.8 miles upstream of mouth of canyon and 3.0 miles northeast of Duarte.
 REGULATION- none.
 CHANNEL- natural, rock and gravel.
 CONTROL- concrete control.
 LENGTH OF RECORD- July to September 1916. July 1917 to date.
 REMARKS- operated and maintained by USGS until October 1, 1971.

WATER YEAR 1989 - 90 (DISCHARGE IN SEC.-FT.)

STATION NO. : U7-R

DRAINAGE AREA : 6.36 SQ. MI.

		OCTOBER	NOVEMBER	DECEMBER	JANUARY	FEBRUARY	MARCH	APRIL	MAY	JUNE	JULY	AUGUST	SEPTEMBER
WATER YEAR 89-90	MEAN	0.1	0.3	0.2	1.3	3.1	0.8	0.8	0.9	0.5	0.0	0.0	0.0
	MAX.	0.3	1.0	0.4	7.4	35.4	1.2	2.3	3.3	2.0	0.0	0.0	0.0
	MIN.	0.0	0.1	0.2	0.4	0.8	0.6	0.4	0.5	0.0	0.0	0.0	0.0
	TOTAL AF	6.9	15.1	15.1	77.0	170.0	51.6	46.8	53.2	30.3	0.0	0.0	0.0

SAN GABRIEL RIVER

below Morris Dam

STATION NO.U8-R

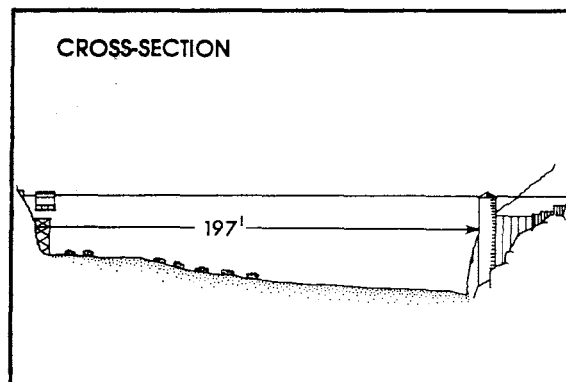
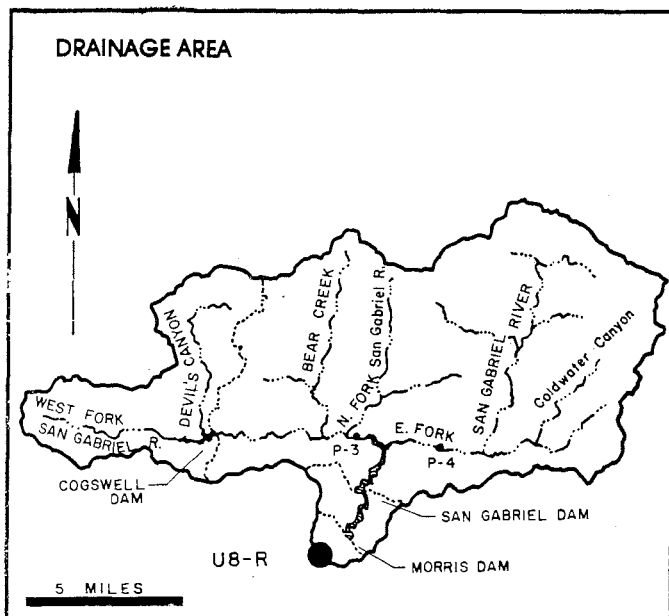
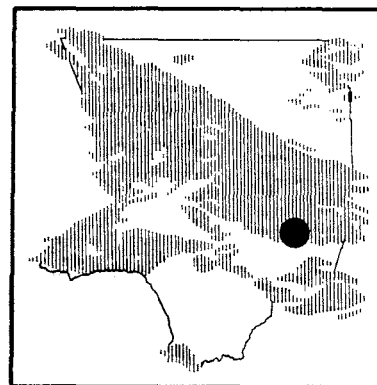

RECORDER- continuous water stage.
 METHOD OF MEASUREMENTS- wading or from cable car.
 DRAINAGE AREA- 212.4 square miles.
 LOCATION- 1.1 miles downstream of Morris Dam, 2.7 miles northeast of Azusa.
 REGULATION- all flows regulated by Cogswell, San Gabriel, and Morris Dams.
 CHANNEL- gravel and boulders, natural section.
 CONTROL- concrete control.
 LENGTH OF RECORD- May 1894 to date.
 REMARKS- flows up to 90 cfs are at times diverted past the station through the Azusa Conduit; flows at station may include imported water from the MWD outlet below Morris Dam.

WATER YEAR 1989 - 90 (DISCHARGE IN SEC.-FT.)

STATION NO.: U8-R

DRAINAGE AREA: 212.40 SQ. MI.

		OCTOBER	NOVEMBER	DECEMBER	JANUARY	FEBRUARY	MARCH	APRIL	MAY	JUNE	JULY	AUGUST	SEPTEMBER
WATER YEAR 89-90	MEAN	41.1	4.8	38.6	32.4	112.0	136.0	151.0	2.5	1.6	0.2	133.0	117.0
	MAX.	166.0	51.4	108.0	145.0	157.0	158.0	160.0	4.0	2.3	0.6	144.0	145.0
	MIN.	1.7	1.8	2.5	2.5	4.9	3.1	79.5	2.2	0.3	0.1	0.1	92.3
TOTAL AF		2530.0	285.0	2374.0	1993.0	6212.0	8348.0	8964.0	156.0	95.2	13.5	8165.0	6968.0

LOS ANGELES RIVER

below Firestone Boulevard

STATION NO. F34D-R

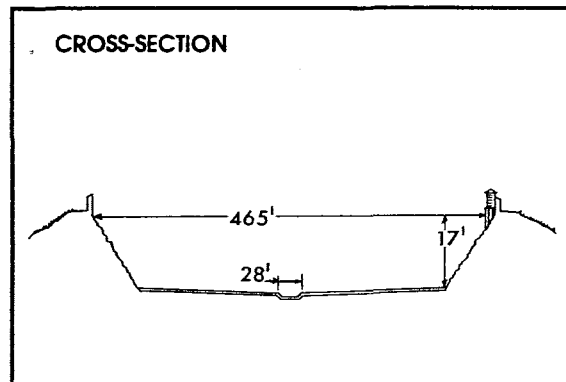
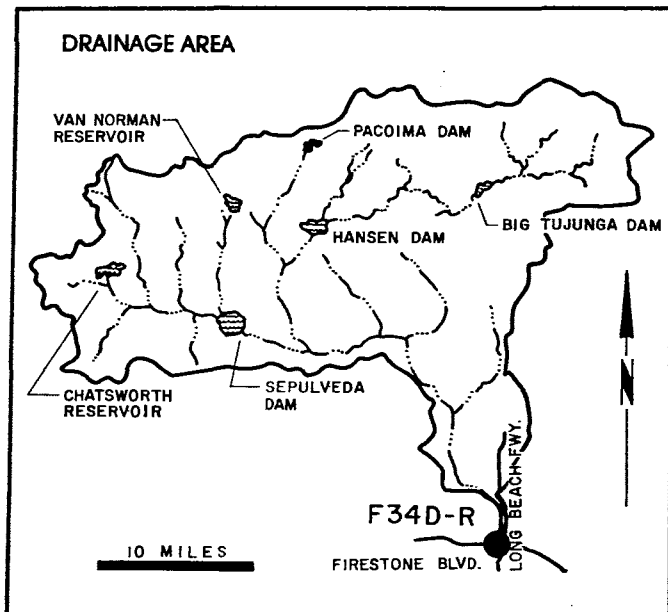
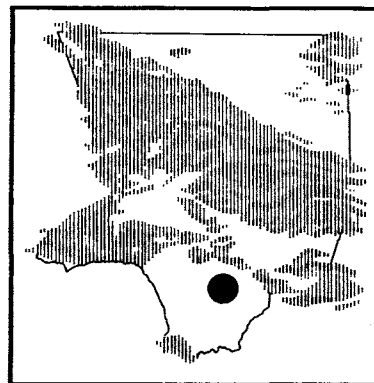

RECORDER- continuous water stage.

METHOD OF MEASUREMENTS- wading or from bridge.

DRAINAGE AREA- 596.0 square miles.

LOCATION- 472.0 feet downstream of Firestone Boulevard 3.0 miles west of Downey.

REGULATION- partially regulated by Sepulveda, Pacoima, Big Tujunga, Hansen, and Devil's Gate Dam; and by several spreading grounds, reservoirs, and debris basins.

CHANNEL- concrete, with rip-rap side slopes, trapezoidal in section, with trapezoidal low-flow channel.

CONTROL- channel forms control.

LENGTH OF RECORD- at Station F34-R. March 1, 1928 to April 11, 1938. at Station F34B-R, April 11, 1938 to November 3, 1949. at Station F34C-R November 4, 1949, to December 11, 1956. at Station F34D-R December 11, 1956 to date.

REMARKS- subject to diversions from Big Tujunga Creek, Arroyo Seco. and other domestic and irrigation diversions.

WATER YEAR 1989 - 90

(DISCHARGE IN SEC-FT.)

STATION NO. : F34D-R

DRAINAGE AREA : 596.00 SQ. MI.

		OCTOBER	NOVEMBER	DECEMBER	JANUARY	FEBRUARY	MARCH	APRIL	MAY	JUNE	JULY	AUGUST	SEPTEMBER
WATER YEAR 89-90	MEAN	145.0	133.0	111.0	208.0	340.0	124.0	133.0	152.0	122.0	118.0	114.0	117.0
	MAX.	493.0	604.0	119.0	1100.0	6060.0	129.0	139.0	1000.0	128.0	126.0	116.0	119.0
	MIN.	124.0	111.0	103.0	100.0	103.0	121.0	121.0	113.0	115.0	115.0	112.0	115.0
TOTAL AF		8898.0	7928.0	6823.0	12779.0	18857.0	7622.0	7910.0	9364.0	7283.0	7246.0	7033.0	6932.0

COMPTON CREEK

near Greenleaf Drive
STATION NO. F37B-R

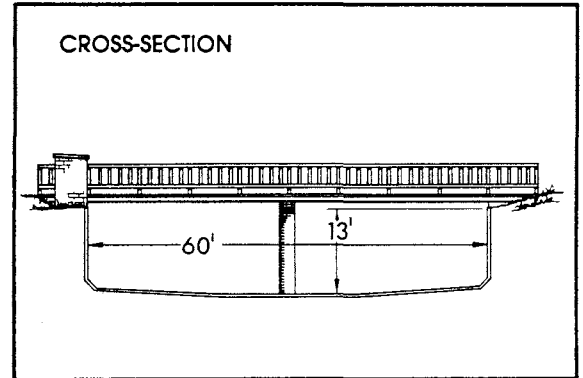
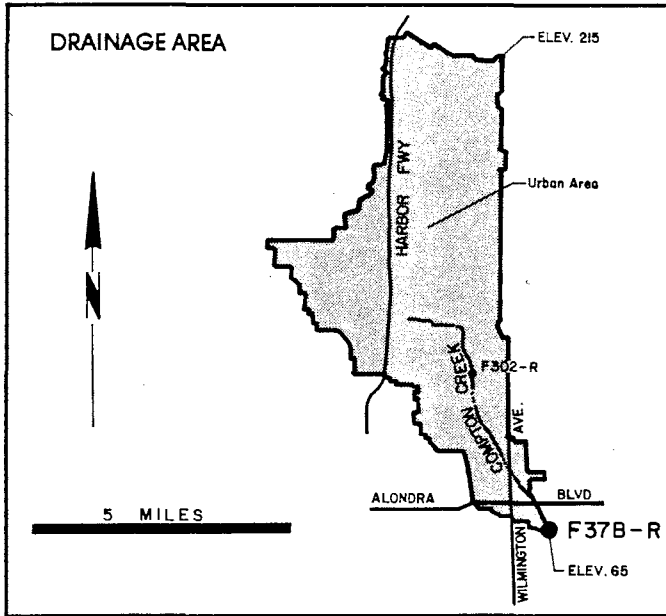
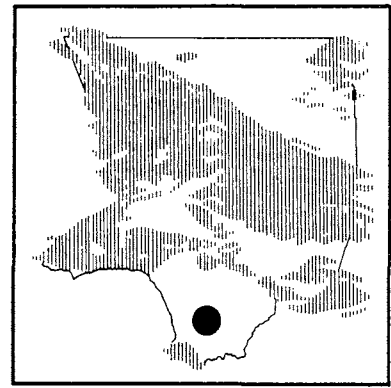

RECORDER- continuous water stage.
 METHOD OF MEASUREMENTS- wading or from bridge.
 DRAINAGE AREA- 22.6 square miles.
 LOCATION- 120.0 feet above Greenleaf Boulevard, 1.5 miles south west of Compton.
 REGULATION- none.
 CHANNEL- concrete, rectangular in section, 60 feet wide by 13 feet deep.
 CONTROL- channel forms control.
 LENGTH OF RECORD- at Station F37-R January 22, 1928 to June 9, 1938. at Station F37B-R October 3, 1938 to date

WATER YEAR 1989 - 90 (DISCHARGE IN SEC.-FT.)

STATION NO. : F37B-R

DRAINAGE AREA : 22.60 SQ. MI.

		OCTOBER	NOVEMBER	DECEMBER	JANUARY	FEBRUARY	MARCH	APRIL	MAY	JUNE	JULY	AUGUST	SEPTEMBER
WATER YEAR 89-90	MEAN	3.2	3.5	0.7	10.8	31.0	0.6	5.2	6.8	1.3	1.1	1.2	1.1
	MAX.	46.3	53.8	1.0	62.4	755.0	2.1	43.5	145.0	3.7	1.4	1.5	1.9
	MIN.	0.5	0.8	0.2	0.3	0.2	0.3	0.3	0.7	0.8	0.9	0.9	0.8
TOTAL AF		197.0	210.0	45.2	665.0	1719.0	33.9	312.0	419.0	79.7	69.2	71.2	65.9

BALLONA CREEK above Sawtelle Boulevard STATION NO. F38C-R

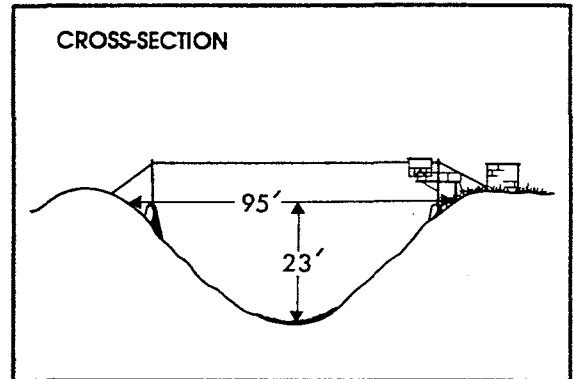
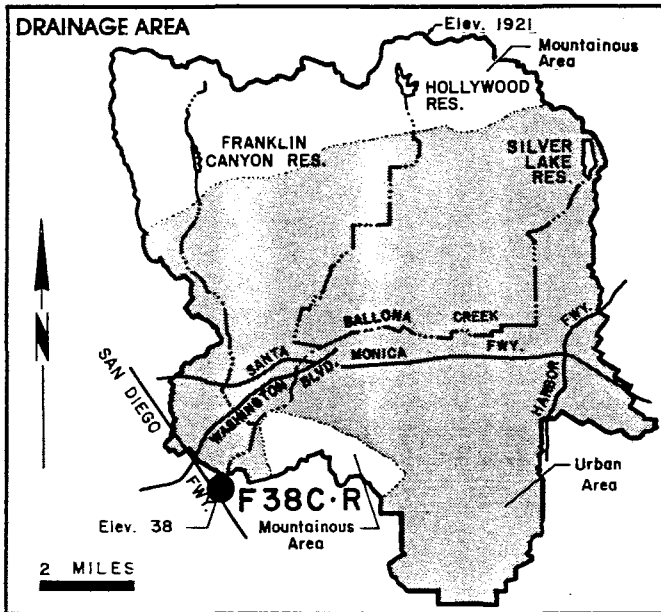
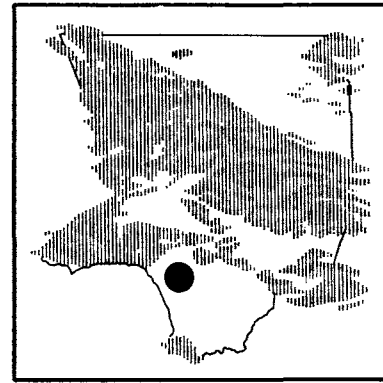

RECORDER- continuous water stage.

METHOD OF MEASUREMENTS- wading or from cable car.

DRAINAGE AREA- 88.6 square miles.

LOCATION- 530.0 feet above Sawtelle Boulevard, 1.5 miles southwest of Culver City.

REGULATION- Stone Canyon Reservoir prior to January, 1951. Upper and Lower Franklin Canyon Reservoir, Hollywood Reservoir, and Silverlake Reservoir.

CHANNEL- concrete rubble, trapezoidal in section.

CONTROL- channel forms control.

LENGTH OF RECORD- at Station F38-R February 27, 1928 to April 27, 1936. at Station F38B-R, May 14, 1936 to August 10, 1967. at Station F38C-R August 10, 1967, to date.

WATER YEAR 1989 - 90
(DISCHARGE IN SEC.-FT.)

STATION NO. : F38C-R

DRAINAGE AREA : 88.60 SQ. MI.

		OCTOBER	NOVEMBER	DECEMBER	JANUARY	FEBRUARY	MARCH	APRIL	MAY	JUNE	JULY	AUGUST	SEPTEMBER
WATER YEAR 89-90	MEAN	22.6	30.4	9.4	55.1	150.0	13.4	30.6	44.5	9.9	11.1	11.1	9.4
	MAX.	303.0	597.0	10.5	336.0	3140.0	72.6	288.0	958.0	11.7	14.6	32.5	11.7
	MIN.	9.9	9.3	8.2	7.6	8.7	9.3	10.5	9.9	7.8	9.3	8.2	8.2
TOTAL AF		1387.0	1807.0	577.0	3389.0	8308.0	823.0	1818.0	2736.0	591.0	685.0	682.0	562.0

SAN GABRIEL RIVER above Spring Street STATION NO. F42B-R

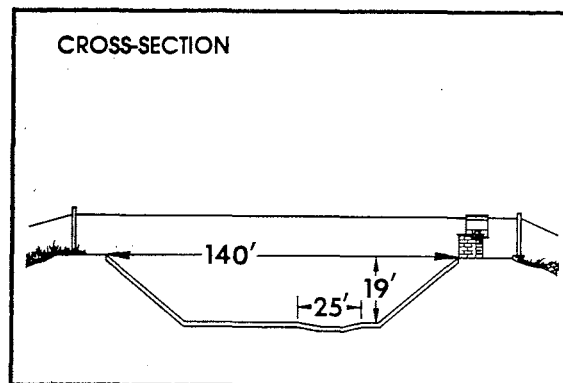
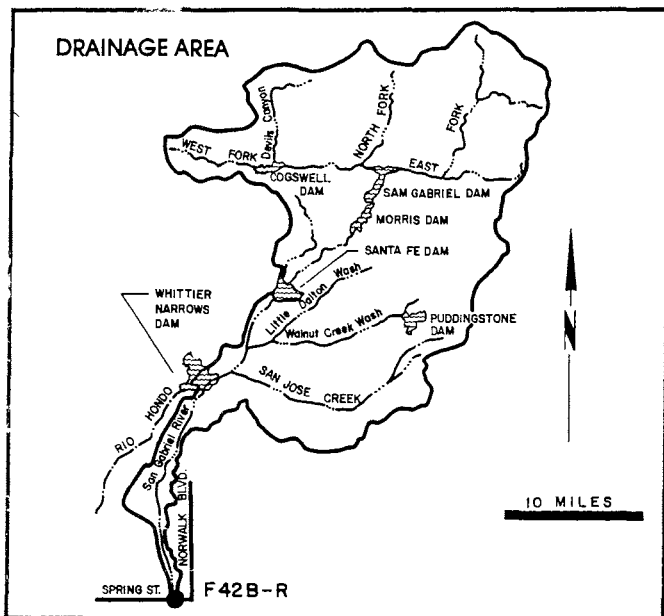
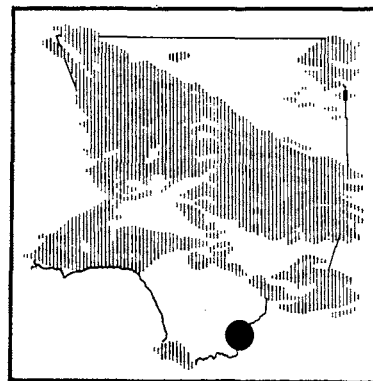

RECORDER- continuous water stage.

METHOD OF MEASUREMENTS- wading or from cable car.

DRAINAGE AREA- 231.0 square miles (excludes area above Santa Fe Dam).

LOCATION- 455.0 feet north of Spring Street, 4.0 miles east of Signal Hill, Long Beach.

REGULATION- partially regulated by Cogswell, San Gabriel, Morris, Santa Fe, Big Dalton, San Dimas, Puddingstone Diversion, Puddingstone, Live Oak, Thompson Creek, and Whittier Narrows Dams, several debris basins, MWD outlet, and several spreading grounds.

CHANNEL- concrete, trapezoidal section with a low-flow channel.

CONTROL- channel forms control.

LENGTH OF RECORD- at Station F42-R February 6, 1928 to May 26, 1964. at Station F42B-R, November 16, 1964 to date.

REMARKS- high flows into Whittier Narrows Reservoir are partially diverted to the Rio Hondo.

WATER YEAR 1989 - 90
(DISCHARGE IN SEC-FT.)

STATION NO. : F42B-R

DRAINAGE AREA : 231.00 SQ. MI.

		OCTOBER	NOVEMBER	DECEMBER	JANUARY	FEBRUARY	MARCH	APRIL	MAY	JUNE	JULY	AUGUST	SEPTEMBER
WATER YEAR 89-90	MEAN	97.7	55.2	53.9	110.0	167.0	115.0	111.0	58.8	35.5	36.4	65.5	73.0
	MAX.	151.0	141.0	109.0	229.0	880.0	151.0	187.0	217.0	62.8	56.0	91.2	135.0
	MIN.	37.1	35.5	45.8	45.0	63.3	41.2	45.1	40.5	4.3	20.1	26.7	35.0
TOTAL AF		6007.0	3285.0	3313.0	6759.0	9287.0	7058.0	6617.0	3618.0	2114.0	2235.0	4026.0	4344.0

RIO HONDO above Stewart and Gray Road STATION NO. F45B-R

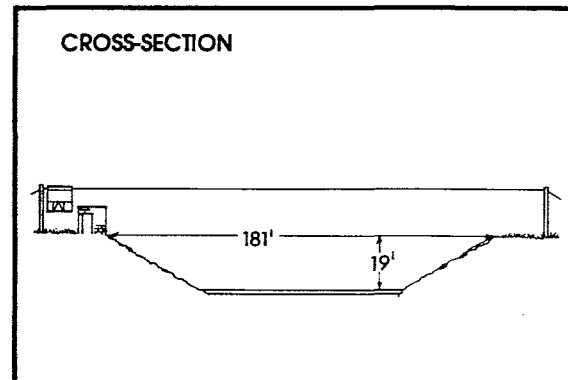
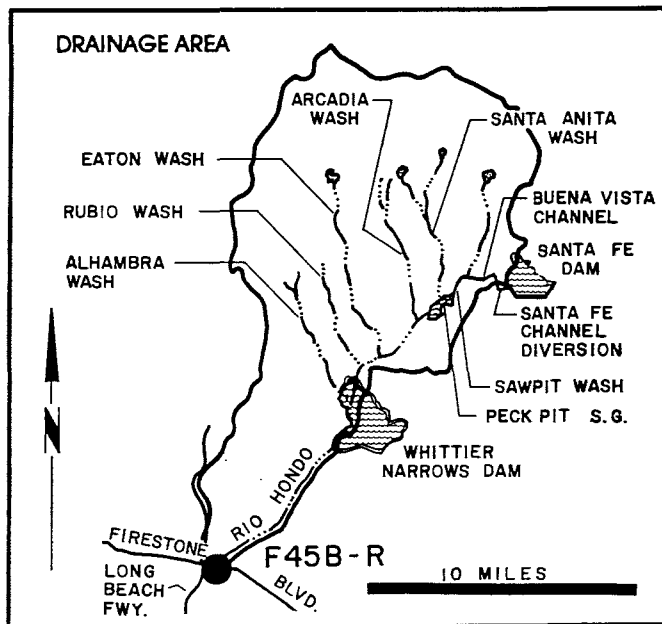
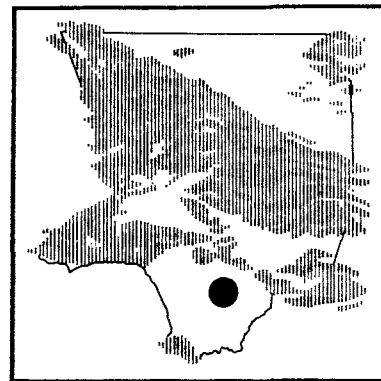

RECORDER- continuous water stage.

METHOD OF MEASUREMENTS- wading or from cable car.

DRAINAGE AREA- 140 square miles (excludes area above Santa Fe Dam).

LOCATION- 0.6 mile upstream of the confluence of Rio Hondo and Los Angeles River, 1.5 miles west of Downey.

REGULATION- partially regulated by Sierra Madre, Santa Anita, Sawpit, Eaton, Santa Fe, and Whittier Narrows Dams, several debris basins, and spreading grounds.

CHANNEL- concrete with rip-rap side slopes. trapezoidal in section.

CONTROL- channel forms control.

LENGTH OF RECORD- at Station F45-R March 1, 1928 to April 18, 1951. at Station F45B-R October 31, 1951 to date.

REMARKS- subject to diversions from Eaton Creek, Monrovia Creek, Sawpit Creek, Little Santa Anita Canyon and other locations for irrigation and spreading. High flows from San Gabriel River may flow into Rio Hondo above Whittier Narrows Dam.

WATER YEAR 1989 - 90 (DISCHARGE IN SEC.-FT.)

STATION NO. : F45B-R

DRAINAGE AREA : 140.00 SQ. MI.

		OCTOBER	NOVEMBER	DECEMBER	JANUARY	FEBRUARY	MARCH	APRIL	MAY	JUNE	JULY	AUGUST	SEPTEMBER
WATER YEAR 89-90	MEAN	2.9	2.3	0.6	8.2	184.0	1.0	2.3	11.8	0.2	0.4	0.3	0.9
	MAX.	42.0	29.5	1.2	64.8	5030.0	11.2	46.0	358.0	0.5	1.3	1.2	5.5
	MIN.	1.0	0.2	0.1	0.3	0.1	0.3	0.1	0.1	0.1	0.1	0.1	0.1
TOTAL AF		180.0	135.0	35.9	505.0	10202.0	63.9	138.0	725.0	11.3	26.8	20.8	56.3

DUME CREEK

at Pacific Coast Highway

STATION NO. F53-R

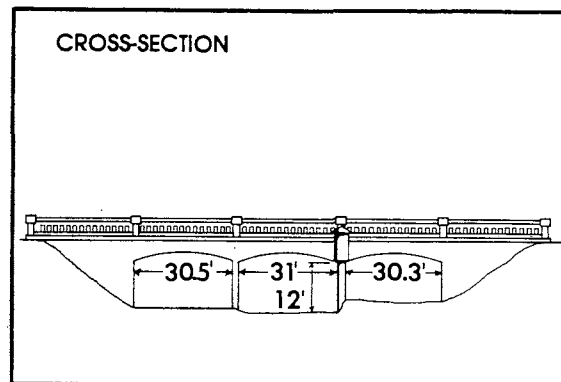
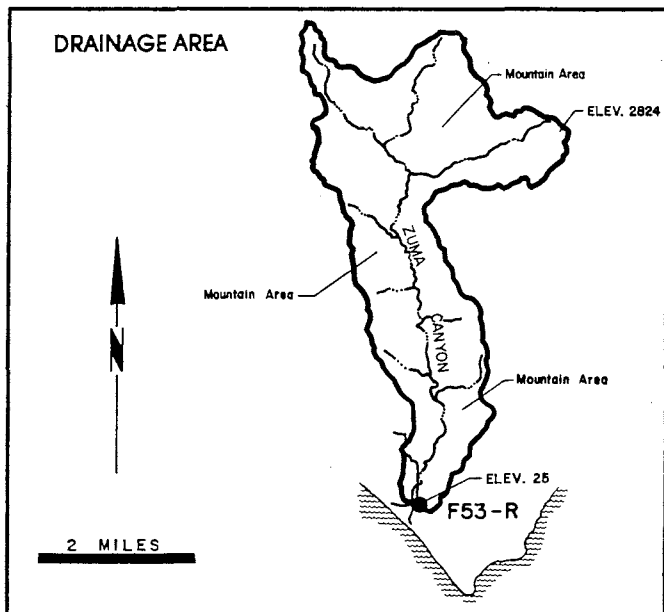
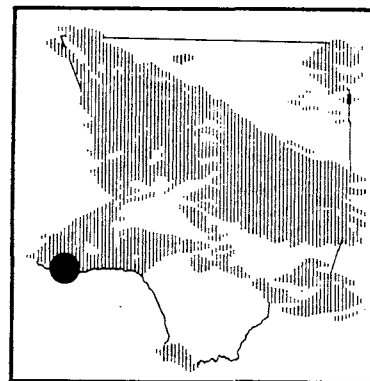

RECORDER- continuous water stage.
 METHOD OF MEASUREMENTS- low flows measured by wading. High flows measured from highway bridge.
 DRAINAGE AREA- 8.8 square miles.
 LOCATION- on the downstream side of Pacific Coast Highway bridge near Dume Point about 0.2 miles from Pacific Ocean.
 REGULATION- none.
 CHANNEL- sand and gravel.
 CONTROL- channel forms control.
 LENGTH OF RECORD- January 15, 1930 to November 26, 1937 and November 3, 1938 to date.

WATER YEAR 1989 - 90
 (DISCHARGE IN SEC.-FT.)

STATION NO. : F53-R

DRAINAGE AREA : 8.80 SQ. MI.

		OCTOBER	NOVEMBER	DECEMBER	JANUARY	FEBRUARY	MARCH	APRIL	MAY	JUNE	JULY	AUGUST	SEPTEMBER
WATER YEAR 89-90	MEAN	0.0	0.0	0.0	0.0	3.0	0.0	0.0	0.0	0.0	0.0	0.0	0.0
	MAX.	0.0	0.0	0.0	0.0	65.0	0.0	0.0	0.0	0.0	0.0	0.0	0.0
	MIN.	0.0	0.0	0.0	0.0	0.0	0.0	0.0	0.0	0.0	0.0	0.0	0.0
TOTAL AF		0.0	0.0	0.0	0.0	164.6	0.0	0.0	0.0	0.0	0.0	0.0	0.0

TOPANGA CREEK above Mouth of Canyon STATION NO. F54B-R

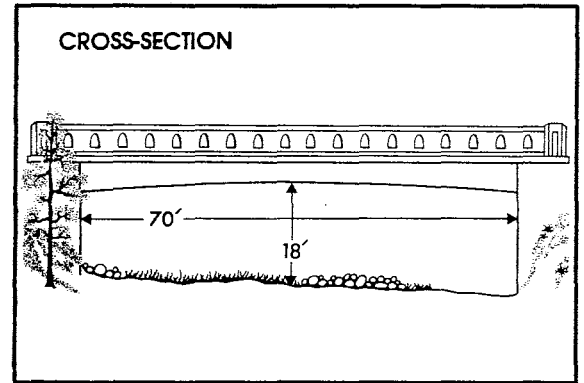
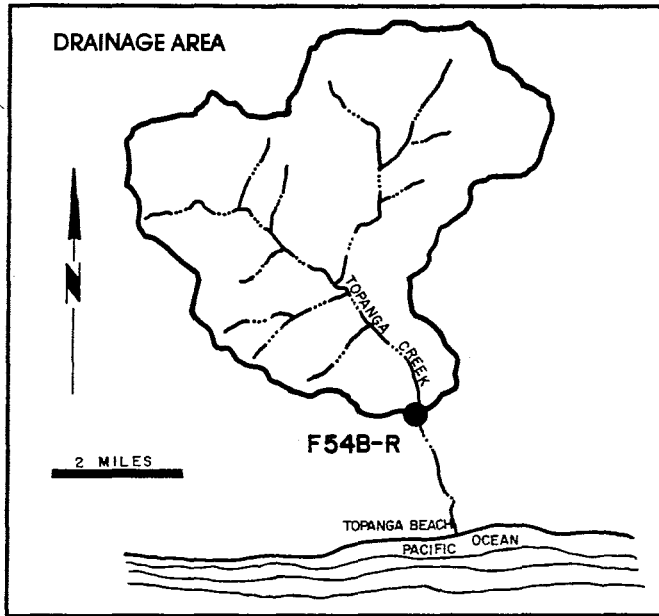
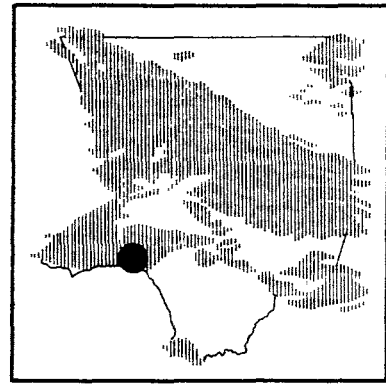

RECORDER- continuous water stage.
 METHOD OF MEASUREMENTS- wading.
 DRAINAGE AREA- 18.0 square miles.
 LOCATION- downstream side of Topanga Canyon Road bridge, 2.0 miles north of Topanga Beach.
 REGULATION- none.
 CHANNEL- rock and gravel, natural section.
 CONTROL- none.
 LENGTH OF RECORD- at Station F54-R January 1, 1930 to June 4, 1940. at Station F54B-R, June 5, 1940 to date.

WATER YEAR 1989 - 90 (DISCHARGE IN SEC.-FT.)

STATION NO. : F54B-R

DRAINAGE AREA : 18.00 SQ. MI.

		OCTOBER	NOVEMBER	DECEMBER	JANUARY	FEBRUARY	MARCH	APRIL	MAY	JUNE	JULY	AUGUST	SEPTEMBER
WATER YEAR 89-90	MEAN	0.2	0.1	0.3	0.3								
	MAX.	0.4	0.4	0.4	1.3				STATION	REMOVED			
	MIN.	0.1	0.1	0.2	0.2								
TOTAL AF		10.3	8.7	16.1	21.2								

RIO HONDO

above Mission Bridge

STATION NO. F64-R

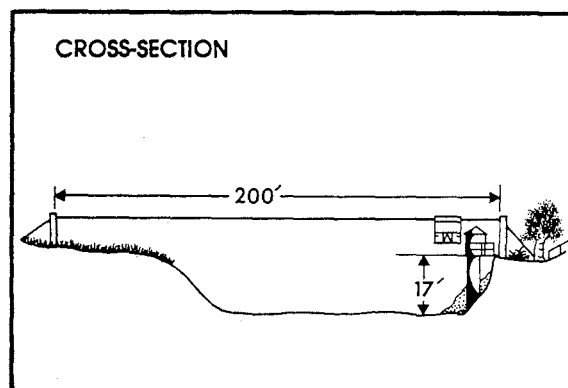
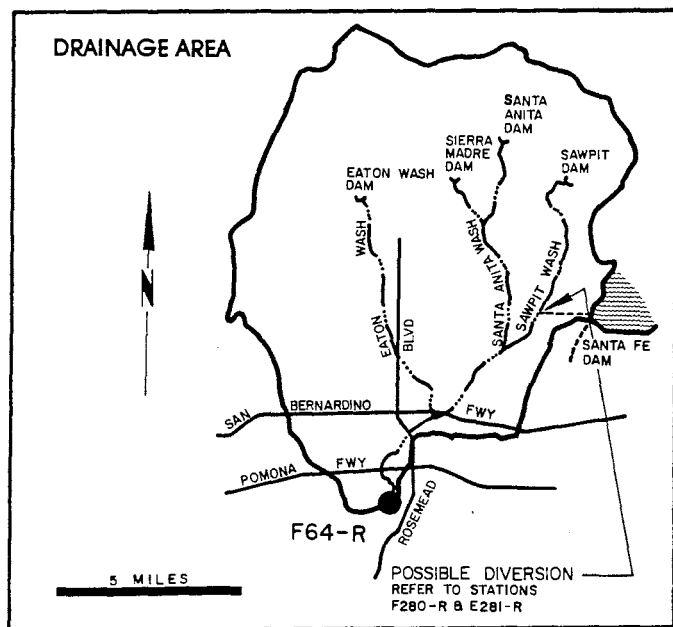
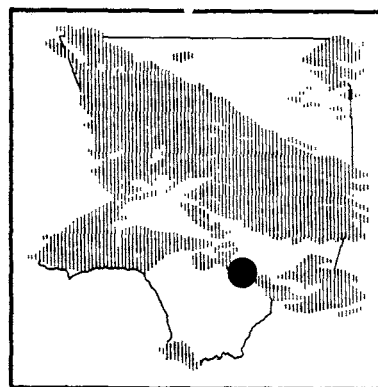

RECORDER- continuous water stage.
 METHOD OF MEASUREMENTS- wading or from cable car.
 DRAINAGE AREA- 115 square miles (excludes area above Santa Fe Dam).
 LOCATION- 1,000 feet above San Gabriel Boulevard, west of Rosemead Boulevard, 2.0 miles northeast of Montebello.
 REGULATION- partially regulated by Sierra Madre, Santa Anita, Sawpit, Eaton, and Santa Fe Dams and several debris basins.
 CHANNEL- sand and silt, natural in section.
 CONTROL- none.
 LENGTH OF RECORD- July 1, 1928 to date.
 REMARKS- subject to diversions; water purchased from the MWD passes this station for spreading in the coastal basin.

WATER YEAR 1989 - 90

(DISCHARGE IN SEC.-FT.)

STATION NO. : F64-R

DRAINAGE AREA : 115.00 SQ. MI.

		OCTOBER	NOVEMBER	DECEMBER	JANUARY	FEBRUARY	MARCH	APRIL	MAY	JUNE	JULY	AUGUST	SEPTEMBER
WATER YEAR 89-90	MEAN	7.3	7.3	1.8	60.5	73.8	4.3	27.5	31.7	20.4	40.1	39.0	44.7
	MAX.	136.0	170.0	2.9	782.0	1543.0	42.8	151.0	545.0	41.7	65.6	56.4	59.7
	MIN.	0.5	0.9	1.0	1.1	0.8	0.3	0.0	0.0	0.0	26.3	22.7	30.4
TOTAL AF		447.0	433.0	113.0	3720.0	4106.0	266.0	1636.0	1952.0	1216.0	2463.0	2398.0	2660.0

ALHAMBRA WASH near Klingerman Street STATION NO. F81D-R

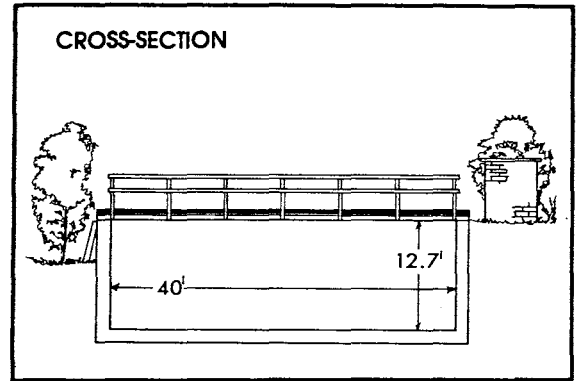
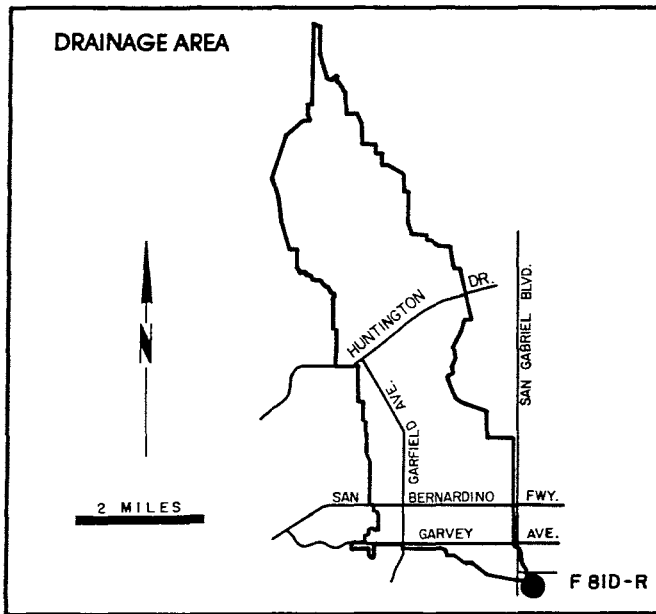
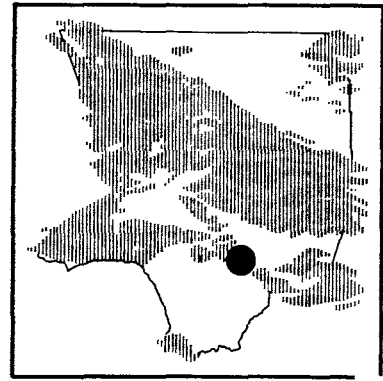

RECORDER- continuous water stage.

METHOD OF MEASUREMENTS- wading or from footbridge.

DRAINAGE AREA- 15.2 square miles.

LOCATION- 250± feet above Klingerman Street and 2,650.0 feet below Garvey Avenue, South San Gabriel.

REGULATION- none.

CHANNEL- concrete, rectangular in section, 40.0 feet wide by 12.7 feet deep.

CONTROL- channel forms control.

LENGTH OF RECORD- at Station F81-R January 14, 1930 to September 30, 1934. at Station F81B-R October 1, 1934 to February 25, 1935. at Station F81C-R February 25, 1935 to April 27, 1936. at Station F81B-R April 27, 1936 to May 22, 1936. at Station F81D-R September 2, 1936 to date.

WATER YEAR 1989 - 90 (DISCHARGE IN SEC.-FT.)

STATION NO. : F81D-R

DRAINAGE AREA : 15.20 SQ. MI.

		OCTOBER	NOVEMBER	DECEMBER	JANUARY	FEBRUARY	MARCH	APRIL	MAY	JUNE	JULY	AUGUST	SEPTEMBER
WATER YEAR 89-90	MEAN	1.8	2.5	1.2	12.3	24.4	1.9	4.1	5.9	1.2	1.3	1.5	1.4
	MAX.	9.1	40.6	1.4	159.0	530.0	12.9	28.5	146.0	1.5	1.6	2.8	1.7
	MIN.	0.9	1.0	1.0	0.9	0.9	1.0	1.1	1.1	0.9	0.9	1.2	1.2
TOTAL AF		108.0	150.0	73.2	758.0	1355.0	118.0	242.0	361.0	69.4	78.7	90.6	82.3

RUBIO WASH at Glendon Wash STATION NO. F82C-R

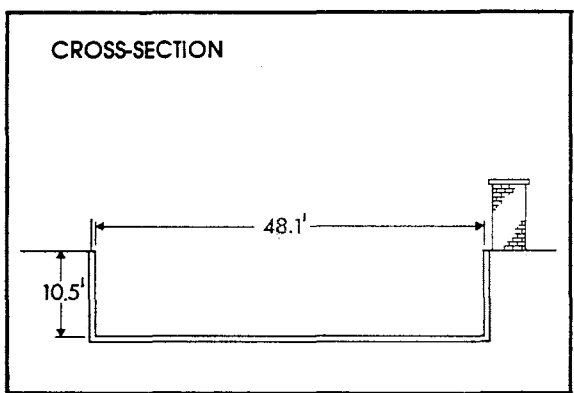
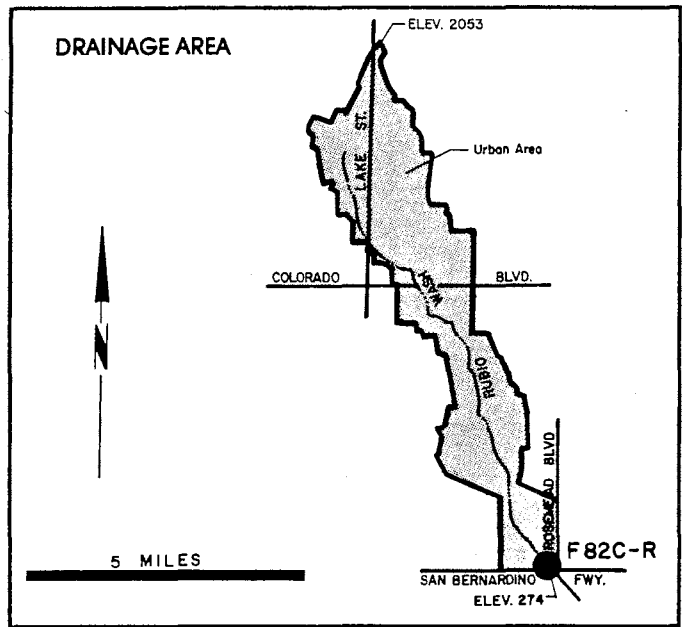
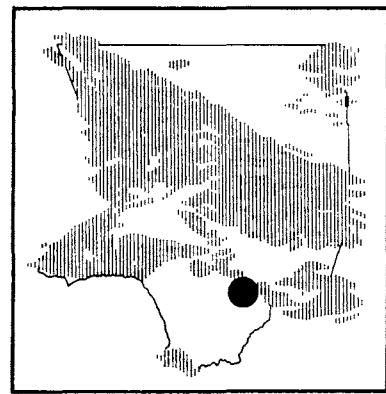

RECORDER- 15 minute punched tape.
 METHOD OF MEASUREMENTS- low flows measured by wading. High flows measured from footbridge at station.
 DRAINAGE AREA- 10.9 square miles.
 LOCATION- on the east side of channel, 10 feet south of the westerly extension of Glendon Way, Rosemead.
 REGULATION- flow partly regulated by Las Flores and Rubio debris basins.
 CHANNEL- rectangular concrete.
 CONTROL- channel forms control.
 LENGTH OF RECORD- see station summary.

WATER YEAR 1989 - 90 (DISCHARGE IN SEC-FT.)

STATION NO. : F82C-R

DRAINAGE AREA : 10.90 SQ. MI.

		OCTOBER	NOVEMBER	DECEMBER	JANUARY	FEBRUARY	MARCH	APRIL	MAY	JUNE	JULY	AUGUST	SEPTEMBER
WATER YEAR 89-90	MEAN	3.2	2.7	2.9	12.0	19.8	3.2	3.9	4.7	0.5	0.6	0.9	0.7
	MAX.	19.7	29.0	5.5	133.0	341.0	16.2	24.8	117.0	1.7	1.3	3.8	2.5
	MIN.	1.9	1.1	2.0	1.9	2.5	0.4	0.3	0.3	0.3	0.4	0.5	0.4
TOTAL AF		198.0	163.0	175.0	740.0	1099.0	194.0	230.0	286.0	30.9	39.1	53.6	40.5

MISSION CREEK at San Gabriel Boulevard STATION NO. F83-R

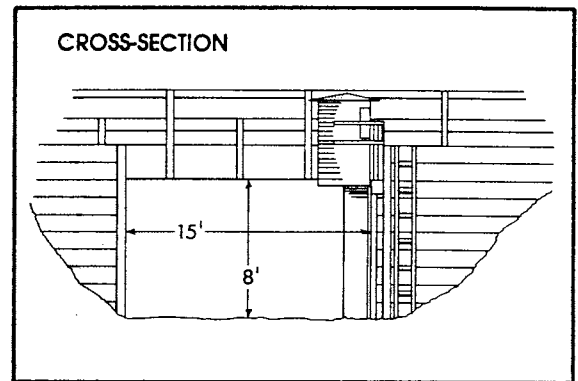
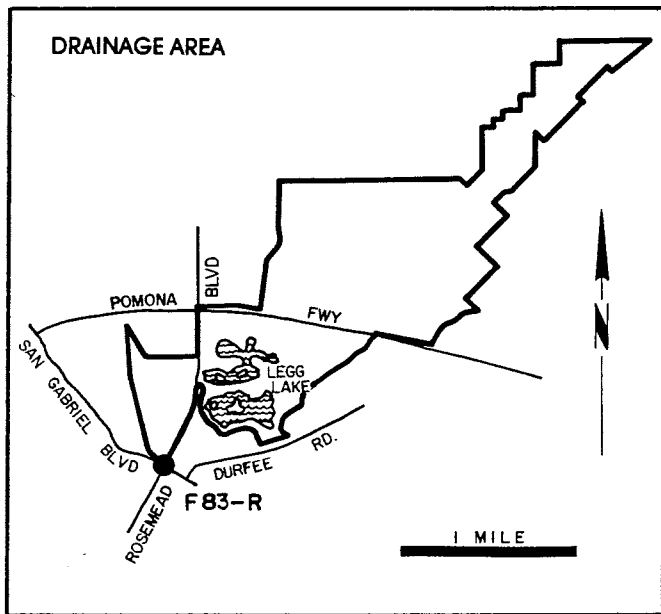
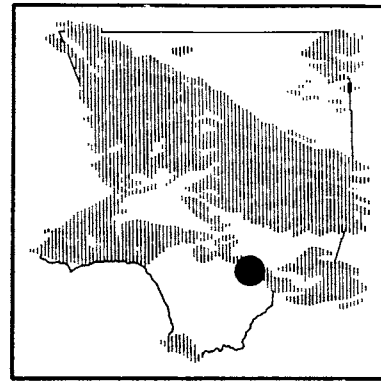

RECORDER- continuous water stage.
 METHOD MEASUREMENTS- wading or from bridge.
 DRAINAGE AREA- 4.2 square miles.
 LOCATION- upstream of San Gabriel Boulevard, 0.2 miles northeast of Montebello.
 REGULATION- partially regulated by outflow from Legg Lake.
 CHANNEL- sand with brush and fences, natural in section.
 CONTROL- channel forms control.
 LENGTH OF RECORD- June 14, 1930 to date.
 REMARKS- nearly all flows originate in rising water.

WATER YEAR 1989 - 90
 (DISCHARGE IN SEC-FT.)

STATION NO. : F83-R

DRAINAGE AREA : 4.20 SQ. MI.

		OCTOBER	NOVEMBER	DECEMBER	JANUARY	FEBRUARY	MARCH	APRIL	MAY	JUNE	JULY	AUGUST	SEPTEMBER
WATER YEAR 89-90	MEAN	0.0	0.0	0.0	0.0	0.0	0.0	0.0	0.0	0.0	0.0	0.0	0.0
	MAX.	0.0	0.0	0.0	0.0	0.0	0.0	0.0	0.0	0.0	0.0	0.0	0.0
	MIN.	0.0	0.0	0.0	0.0	0.0	0.0	0.0	0.0	0.0	0.0	0.0	0.0
TOTAL AF		0.0	0.0	0.0	0.0	0.0	0.0	0.0	0.0	0.0	0.0	0.0	0.0

SANTA CLARA RIVER below Highway 5 STATION NO. F92C-R

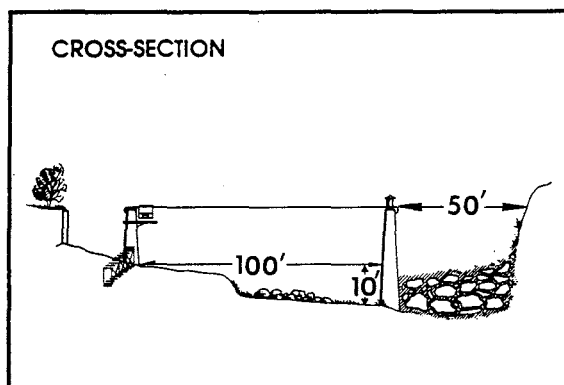
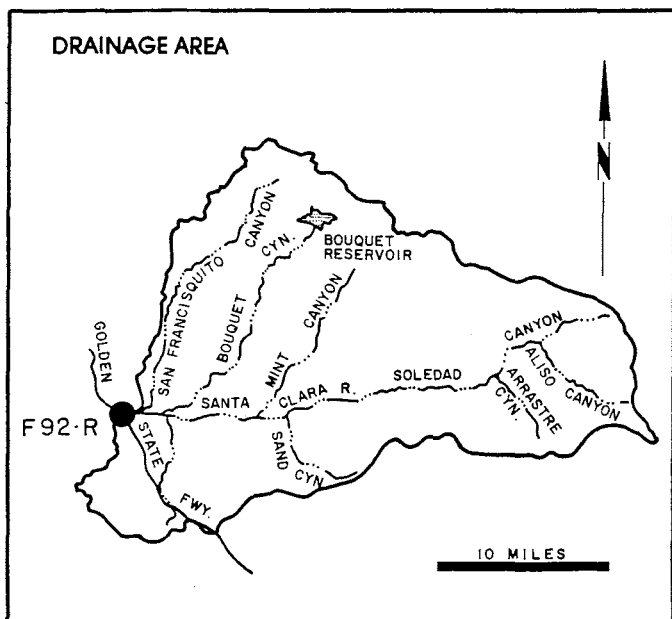
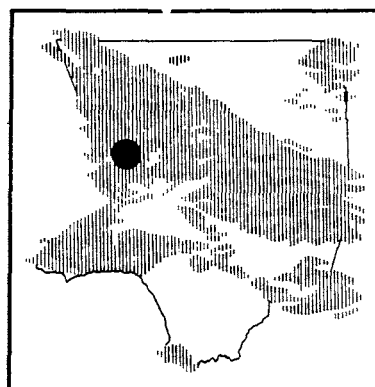

RECORDER- continuous water stage.

METHOD OF MEASUREMENTS- wading or from cable car.

DRAINAGE AREA- 410.4 square miles.

LOCATION- downstream side of Old Highway bridge, 3.0 miles west of Saugus.

REGULATION- partially regulated by Bouquet Canyon and Dry Canyon Reservoirs.

CHANNEL- sand and gravel with brush, natural section.

CONTROL- none.

LENGTH OF RECORD- at Station F92-R January 18, 1930 to March 28, 1938, and September 24, 1956 to date. at Station F92B-R, October 1, 1938 to September 24, 1956.

REMARKS- subject to diversions for irrigation.

WATER YEAR 1989 - 90 (DISCHARGE IN SEC.-FT.)

STATION NO.: F92C-R

DRAINAGE AREA: 410.40 SQ. MI.

		OCTOBER	NOVEMBER	DECEMBER	JANUARY	FEBRUARY	MARCH	APRIL	MAY	JUNE	JULY	AUGUST	SEPTEMBER
WATER YEAR 89-90	MEAN	10.6	11.4	12.5	12.8	12.0	13.3	12.5	10.8	10.1	7.5	16.9	16.5
	MAX.	11.2	12.4	12.7	13.1	12.6	14.8	15.0	10.9	11.2	12.5	18.0	17.0
	MIN.	10.1	10.1	12.4	12.7	11.7	12.0	10.7	10.7	7.8	4.9	13.0	16.2
TOTAL AF		652.0	676.0	770.0	789.0	667.0	820.0	744.0	661.0	601.0	462.0	1037.0	984.0

PALLETT CREEK at Valyermo Highway STATION NO. F122-R

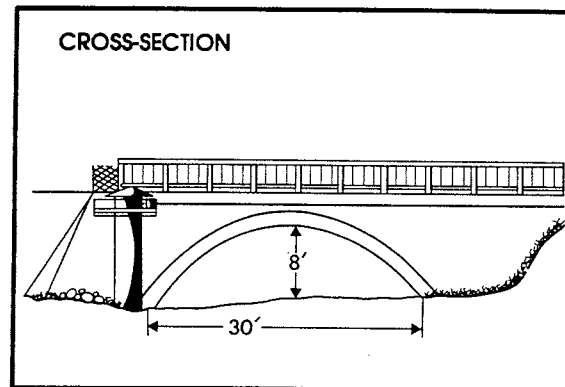
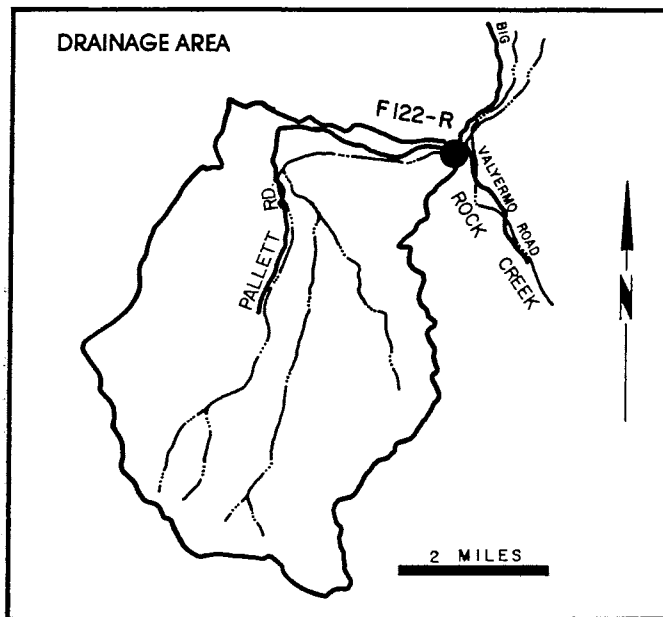
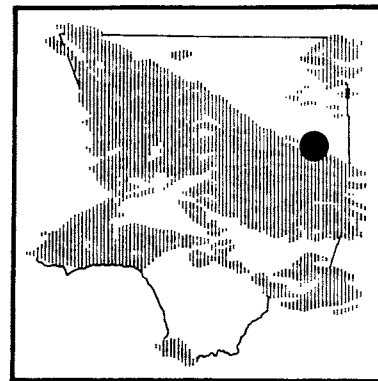

RECORDER- continuous water stage.

METHOD OF MEASUREMENTS- wading or from bridge.

DRAINAGE AREA- 15.8 square miles.

LOCATION- upstream side of Valyermo Highway bridge, 5.0 miles southeast of Pearblossom.

REGULATION- none.

CHANNEL- sand and gravel, natural section.

CONTROL- channel forms control for low flows; bridge culvert forms control for high flows.

LENGTH OF RECORD- at Station F122-S December 29, 1930 to October 31, 1961. at Station F122-R, October 31, 1961 to date.

WATER YEAR 1989 - 90 (DISCHARGE IN SEC.-FT.)

STATION NO. : F122-R

DRAINAGE AREA : 15.80 SQ. MI.

		OCTOBER	NOVEMBER	DECEMBER	JANUARY	FEBRUARY	MARCH	APRIL	MAY	JUNE	JULY	AUGUST	SEPTEMBER
WATER YEAR 89-90	MEAN	0.0	0.0	0.0	0.0	0.0	0.0	0.0	0.0	0.0	0.0	0.0	0.0
	MAX.	0.0	0.0	0.0	0.0	0.0	0.0	0.0	0.0	0.0	0.0	0.0	0.0
	MIN.	0.0	0.0	0.0	0.0	0.0	0.0	0.0	0.0	0.0	0.0	0.0	0.0
	TOTAL AF	0.0	0.0	0.0	0.0	0.0	0.0	0.0	0.0	0.0	0.0	0.0	0.0

SANTIAGO CREEK

above Little Rock Creek
STATION NO. F125-R

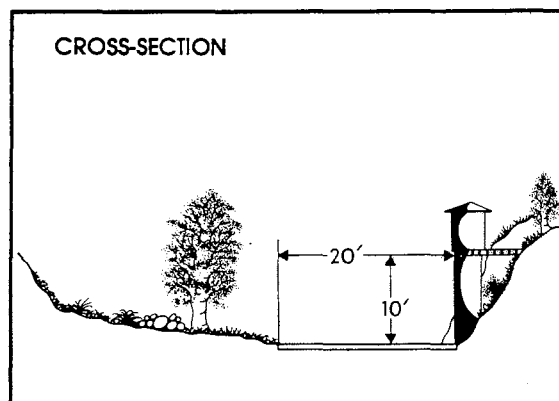
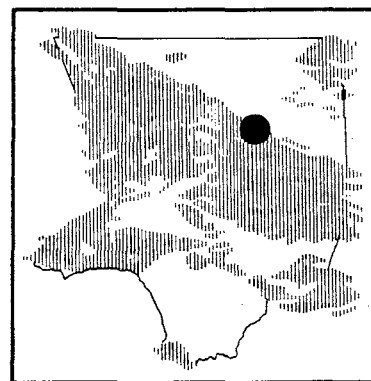
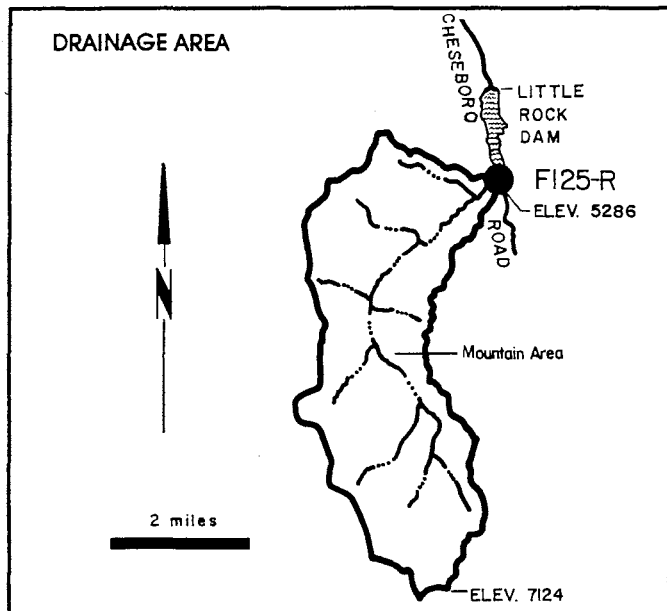

RECORDER- continuous water stage.
 METHOD OF MEASUREMENTS- wading.
 DRAINAGE AREA- 11.2 square miles.
 LOCATION- 1,000 feet above Little Creek and 4.5 miles south of Little Rock.
 REGULATION- none.
 CHANNEL- sand, gravel and boulders.
 CONTROL- concrete and rubble wall.
 LENGTH OF RECORD- September 29, 1953 to date.
 REMARKS- no high flow measurements.

WATER YEAR 1989 - 90
 (DISCHARGE IN SEC.-FT.)

STATION NO. : F125-R

DRAINAGE AREA : 11.20 sq. MI.

		OCTOBER	NOVEMBER	DECEMBER	JANUARY	FEBRUARY	MARCH	APRIL	MAY	JUNE	JULY	AUGUST	SEPTEMBER
WATER YEAR 89-90	MEAN	0.0	0.0	0.0	0.0	0.0	0.0	0.0	0.0	0.0	0.0	0.0	0.0
	MAX.	0.0	0.0	0.0	0.0	0.0	0.0	0.0	0.0	0.0	0.0	0.0	0.0
	MIN.	0.0	0.0	0.0	0.0	0.0	0.0	0.0	0.0	0.0	0.0	0.0	0.0
TOTAL AF		0.0	0.0	0.0	0.0	0.0	0.0	0.0	0.0	0.0	0.0	0.0	0.0

MALIBU CREEK

below Cold Creek

STATION NO. F130-R

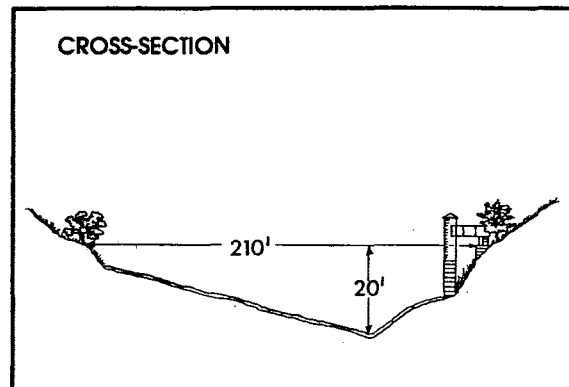
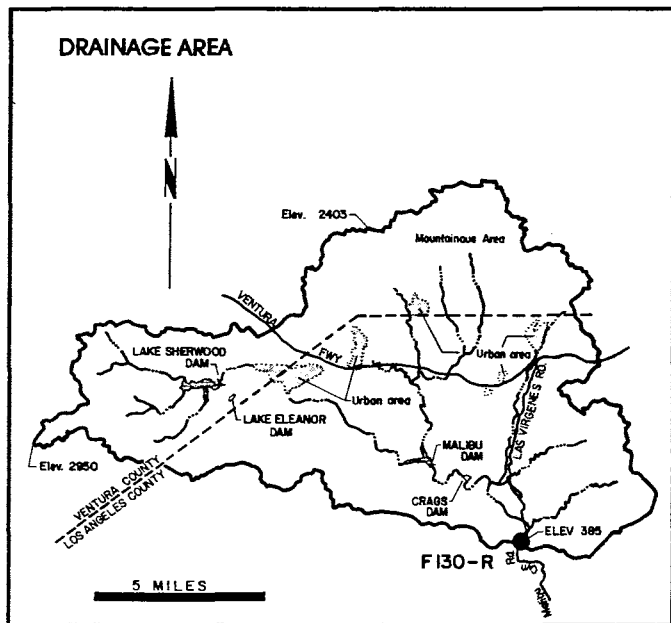
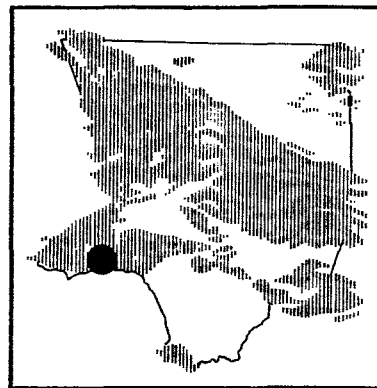

RECORDER- continuous water stage.

METHOD OF MEASUREMENTS- wading on from cable car.

DRAINAGE AREA- 104.96 square miles

LOCATION- 0.2± mile downstream of Cold Creek, 6.0 miles southwest of Calabasas.

REGULATION- Lake Sherwood Dam, Lake Eleanor Dam, Malibu Lake Dam, and Crag's Dam. Other small recreational dams affect low summer flows.

CHANNEL- coarse sand and gravel, lined with trees and brush, natural in section.

CONTROL- concrete stabilizer.

LENGTH OF RECORD- January 17, 1931 to date.

REMARKS- cableway washed out on January 25, 1969; no high flow measurements since that date.

WATER YEAR 1989 - 90
(DISCHARGE IN SEC-FT.)

STATION NO. : F130-R

DRAINAGE AREA : 104.96 SQ. MI.

		OCTOBER	NOVEMBER	DECEMBER	JANUARY	FEBRUARY	MARCH	APRIL	MAY	JUNE	JULY	AUGUST	SEPTEMBER
WATER YEAR 89-90	MEAN	8.6	8.1	6.4	25.4	30.5	8.5	8.9	4.4				1.6
	MAX.	13.0	31.2	7.8	140.0	360.0	12.6	19.5	9.2	DATA	NOT AVAILABLE		2.8
	MIN.	3.0	3.1	3.9	6.8	11.0	5.0	6.1	2.0				0.7
TOTAL AF		530.0	481.0	392.0	1562.0	1693.0	523.0	530.0	270.0				94.2

MONTEBELLO STORM DRAIN

above Rio Hondo

STATION NO. F181-R

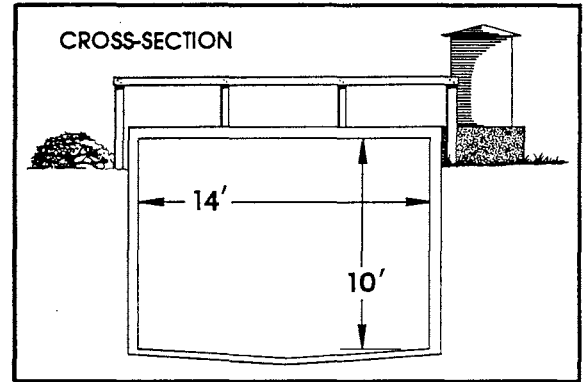
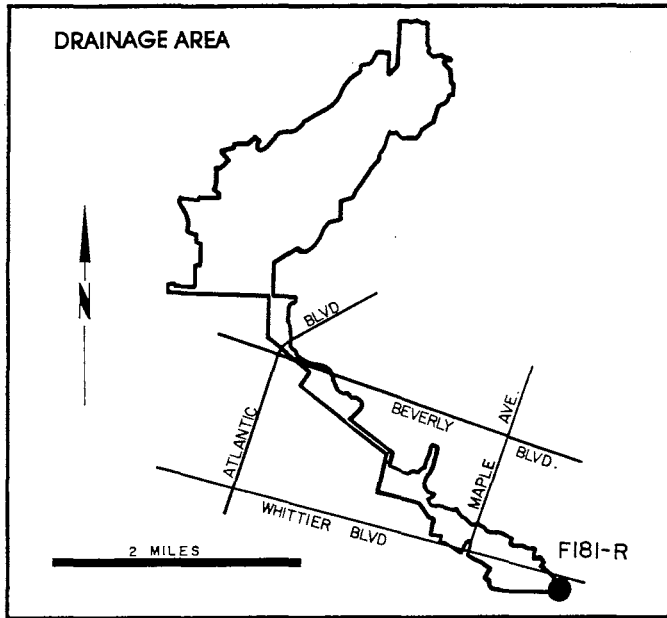
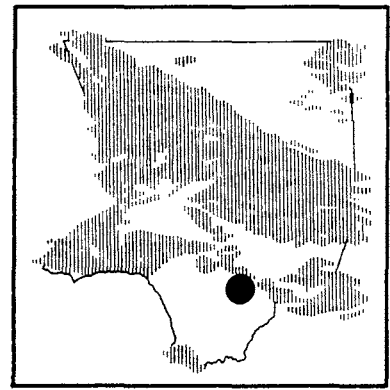

RECORDER- continuous water stage.
 METHOD OF MEASUREMENTS- wading or from footbridge.
 DRAINAGE AREA- 9.6 square miles.
 LOCATION- 150.0 feet east of Mines Avenue and 500.0 feet west of Rio Hondo.
 REGULATION- none.
 CHANNEL- 14.0-foot by 10.0-foot concrete, box section.
 CONTROL- channel forms control.
 LENGTH OF RECORD- January 12, 1932 to date.
 REMARKS- may be affected by backwater during flood flows.

WATER YEAR 1989 - 90
 (DISCHARGE IN SEC-FT.)

STATION NO. : F181-R

DRAINAGE AREA : 9.60 SQ. MI.

		OCTOBER	NOVEMBER	DECEMBER	JANUARY	FEBRUARY	MARCH	APRIL	MAY	JUNE	JULY	AUGUST	SEPTEMBER
WATER YEAR 89-90	MEAN	0.8	0.6	0.3	1.8	5.7	0.9	0.7	1.5	0.2	0.3	0.2	0.2
	MAX.	10.2	6.5	0.5	20.3	110.0	3.9	9.0	41.9	0.3	0.8	0.3	0.3
	MIN.	0.3	0.2	0.2	0.1	0.2	0.1	0.1	0.1	0.1	0.1	0.1	0.1
TOTAL AF		49.0	33.3	19.4	111.0	319.0	55.3	39.1	92.0	10.3	16.7	12.7	9.1

SAN GABRIEL RIVER at Foothill Boulevard STATION NO. F190-R

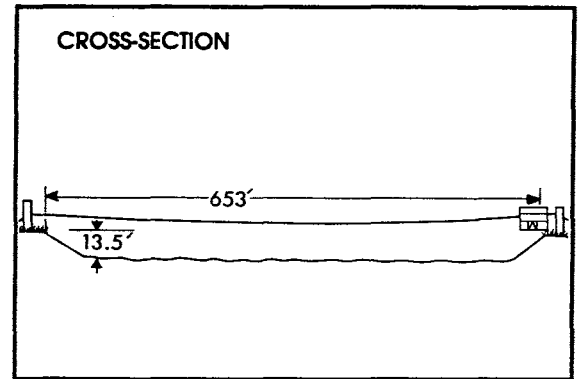
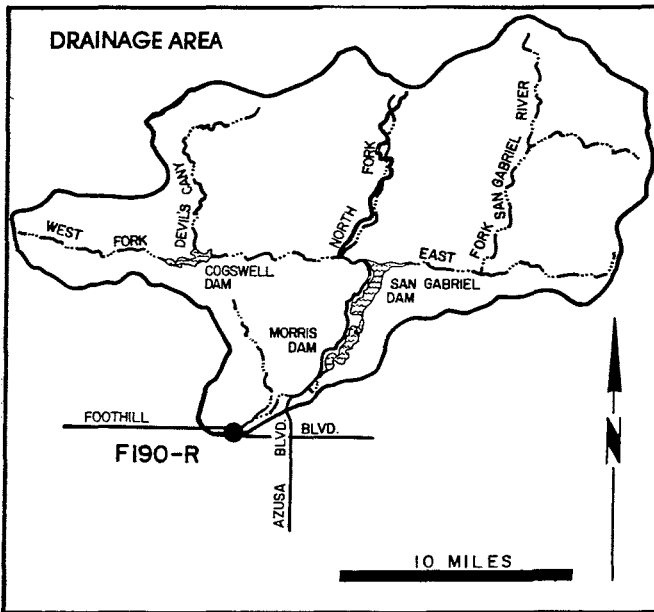
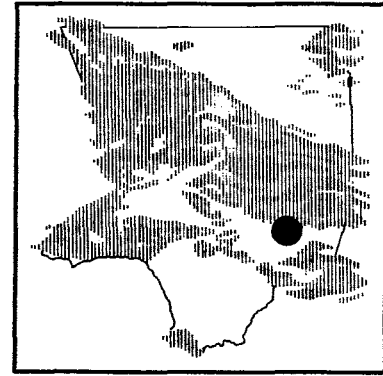

RECORDER- continuous water stage.
 METHOD OF MEASUREMENTS- wading or from cable car.
 DRAINAGE AREA- 230.0 square miles.
 LOCATION- downstream side of Foothill Boulevard bridge, 2.0 miles west of Azusa.
 REGULATION- partially regulated by Cogswell, San Gabriel, and Morris Dams.
 CHANNEL- sand, gravel and rock, trapezoidal section with soft bottom.
 CONTROL- gunited rock stabilizers.
 LENGTH OF RECORD- February 22, 1932 to date.
 REMARKS- flows may include imported water originating at the Metropolitan Water District outlet below Morris Dam.

WATER YEAR 1989 - 90 (DISCHARGE IN SEC.-FT.)

STATION NO. : F190-R

DRAINAGE AREA : 230.00 SQ. MI.

		OCTOBER	NOVEMBER	DECEMBER	JANUARY	FEBRUARY	MARCH	APRIL	MAY	JUNE	JULY	AUGUST	SEPTEMBER
WATER YEAR 89-90	MEAN	18.3	20.5	0.3	0.8	25.9	82.3	95.9	10.6	0.0	0.0	39.3	27.7
	MAX.	94.7	30.8	9.4	11.2	75.5	138.0	145.0	35.1	0.0	0.0	65.7	55.3
	MIN.	0.0	0.0	0.0	0.0	0.0	0.0	76.2	0.0	0.0	0.0	0.0	9.8
TOTAL AF		1124.0	1222.0	18.6	51.2	1440.0	5062.0	5704.0	651.0	0.0	0.0	2415.0	1649.0

RIO HONDO

below Lower Azusa Road
STATION NO. F192B-R

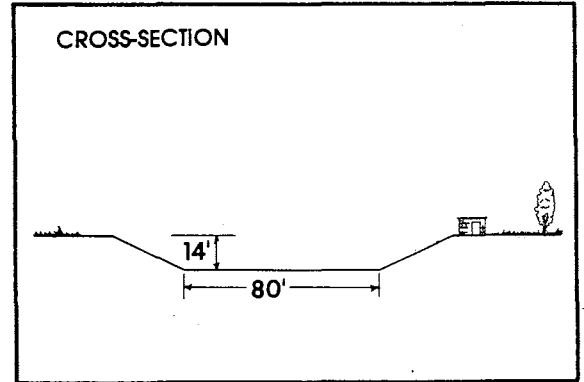
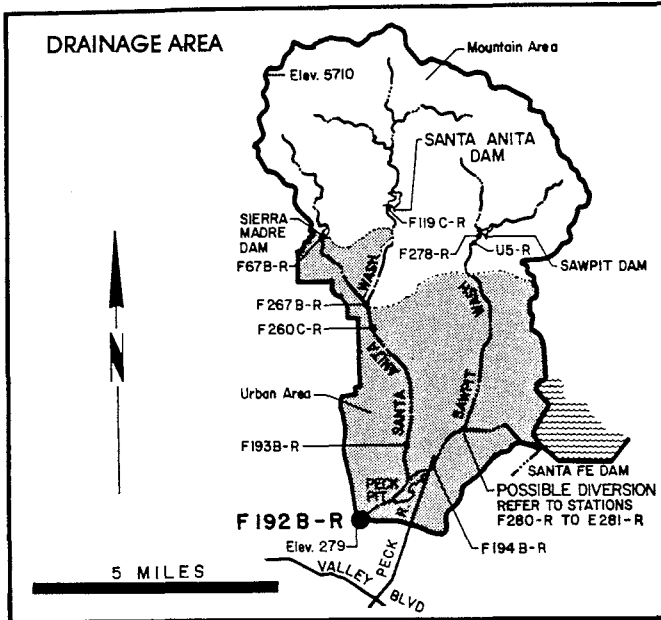
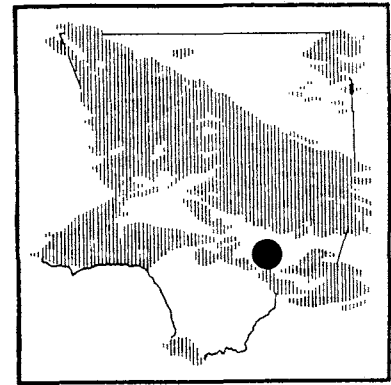

RECORDER- continuous water stage.
 METHOD OF MEASUREMENTS- wading.
 DRAINAGE AREA- 40.9 square miles (excludes area above Santa Fe Dam).
 LOCATION- 300.0 feet downstream from Lower Azusa Road, 1.5 miles north of El Monte.
 REGULATION- partially regulated by Sierra Madre Dam, Santa Anita Dam, Sawpit Dam, Santa Fe Dam, Peck Pit, Buena Vista Pit, and several debris basins.
 CHANNEL- concrete, trapezoidal in section.
 CONTROL- channel forms control.
 LENGTH OF RECORD- at Station F192-R February 22, 1932 to May 7, 1958. at Station F192B-R May 7, 1958 to date.
 REMARKS- subject to diversions from Monrovia, Sawpit, and Little Santa Anita Creeks. Also from the San Gabriel River below Santa Fe Dam; and for irrigation and spreading.

WATER YEAR 1989 - 90 (DISCHARGE IN SEC.-FT.)

STATION NO. : F192B-R

DRAINAGE AREA : 40.90 SQ. MI.

		OCTOBER	NOVEMBER	DECEMBER	JANUARY	FEBRUARY	MARCH	APRIL	MAY	JUNE	JULY	AUGUST	SEPTEMBER
WATER YEAR 89-90	MEAN	0.1	0.1	0.0	0.7	2.1	0.1	0.3	0.6	0.0	0.0	0.1	0.1
	MAX.	1.5	2.7	0.1	7.9	46.2	1.4	2.7	19.7	0.1	0.1	0.8	0.3
	MIN.	0.0	0.0	0.0	0.0	0.0	0.0	0.0	0.0	0.0	0.0	0.0	0.0
TOTAL AF		6.0	5.4	1.4	45.2	119.0	8.9	19.6	39.5	0.4	2.8	6.7	3.4

SANTA ANITA WASH

at Longden Avenue

STATION NO. F193B-R

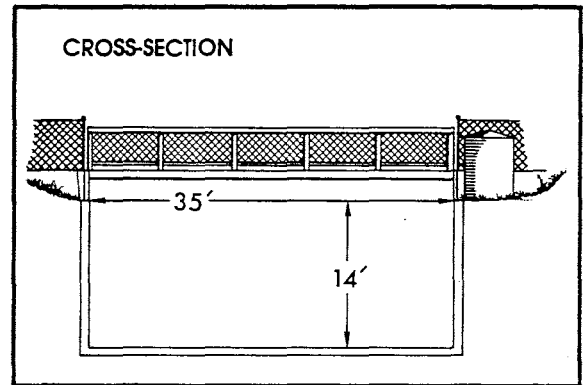
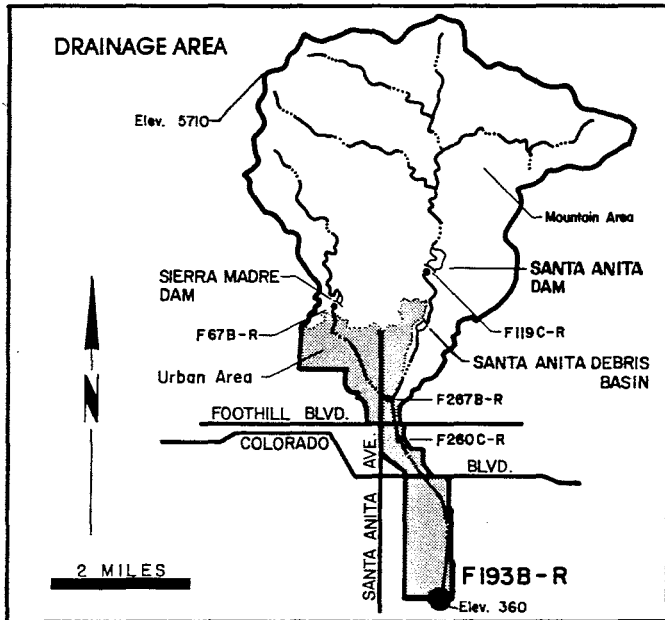
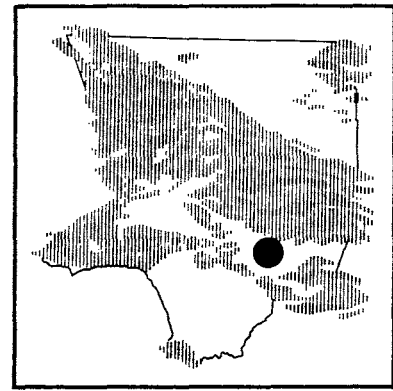

RECORDER - continuous water stage.

METHOD OF MEASUREMENTS- wading or from bridge.

DRAINAGE AREA- 18.8 square miles.

LOCATION - 30.0 feet above Longden Avenue, 1.5 miles south of Arcadia.

REGULATION - regulated by Santa Anita and Sierra Madre Dams, and Santa Anita Debris Basin.

CHANNEL - concrete rectangular section.

CONTROL- channel forms control.

LENGTH OF RECORD- at Station F193-R, April 25, 1932 to March 1, 1938. at Station F193B-R, January 5, 1960 to date.

WATER YEAR 1989 - 90

(DISCHARGE IN SEC.-FT.)

STATION NO. : F193B-R

DRAINAGE AREA : 18.80 SQ. MI.

		OCTOBER	NOVEMBER	DECEMBER	JANUARY	FEBRUARY	MARCH	APRIL	MAY	JUNE	JULY	AUGUST	SEPTEMBER
WATER YEAR 89-90	MEAN	0.3	0.4	0.1	2.7	4.2	0.3	1.0	1.5	0.0	0.0	0.0	0.0
	MAX.	3.6	8.0	0.2	42.5	76.6	3.5	12.0	33.7	0.2	0.0	0.3	0.3
	MIN.	0.0	0.0	0.0	0.0	0.0	0.0	0.0	0.0	0.0	0.0	0.0	0.0
TOTAL AF		20.2	22.0	6.5	163.0	232.0	21.4	58.1	90.8	0.8	0.0	0.8	1.2

SAWPIT WASH

below Live Oak Avenue
STATION NO. F194B-R

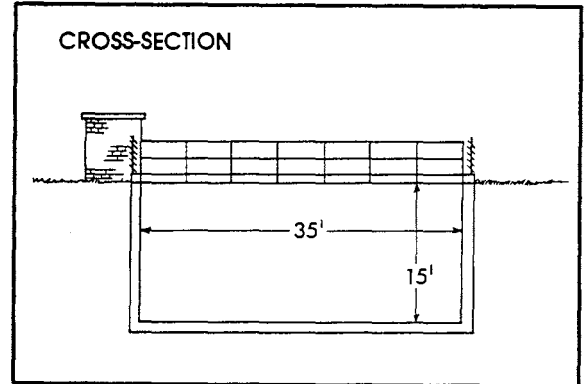
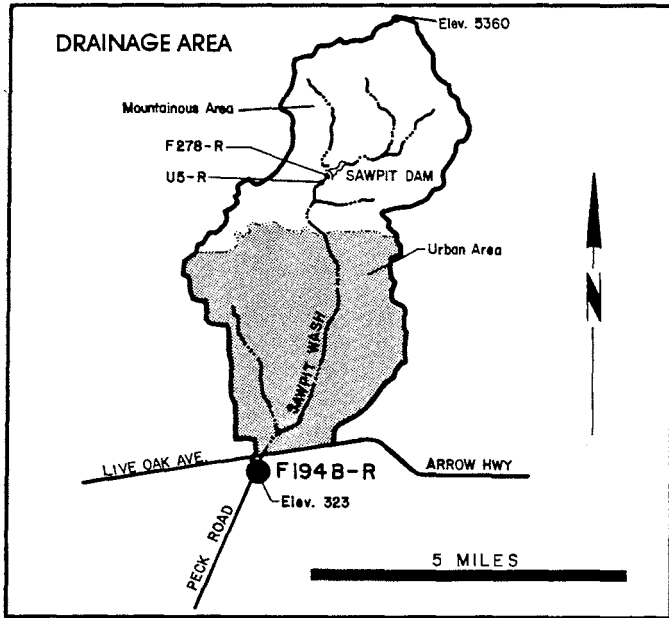
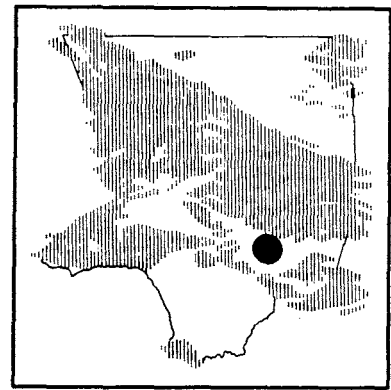

RECORDER- continuous water stage.
 METHOD OF MEASUREMENTS- wading or from footbridge.
 DRAINAGE AREA- 16.1 square miles.
 LOCATION- 1,500 feet below Arrow Highway, 3.0 miles south of Monrovia.
 REGULATION- partially regulated by Sawpit and Santa Fe Dams, and by several debris basins.
 CHANNEL- concrete, rectangular section.
 CONTROL- channel forms control.
 LENGTH OF RECORD- at Station F194-R February 22, 1932 to September 1, 1935. at Station F194B-R December 5, 1960 to date.

WATER YEAR 1989 - 90 (DISCHARGE IN SEC-FT.)

STATION NO. : F194B-R

DRAINAGE AREA : 16.10 SQ. MI.

		OCTOBER	NOVEMBER	DECEMBER	JANUARY	FEBRUARY	MARCH	APRIL	MAY	JUNE	JULY	AUGUST	SEPTEMBER
WATER YEAR 89-90	MEAN	0.3	0.5	0.0	4.2	7.0	0.3	0.9	2.0	0.1	0.0	0.1	0.1
	MAX.	3.9	15.4	0.2	56.7	147.0	5.3	7.9	59.0	0.5	0.1	0.5	0.2
	MIN.	0.0	0.0	0.0	0.0	0.0	0.0	0.0	0.0	0.0	0.0	0.0	0.1
TOTAL AF		20.2	32.3	1.0	260.0	388.0	16.1	50.6	126.0	3.6	0.8	5.6	6.3

SAN GABRIEL-AZUSA CONDUIT

at 25 ft. Weir below San Gabriel Dam

STATION NO. F250-R

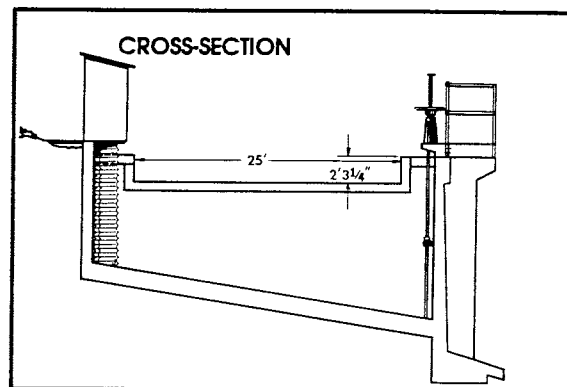
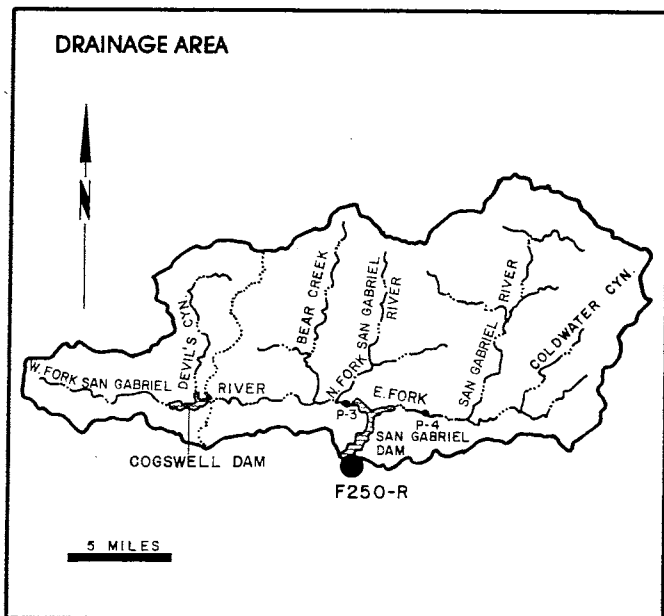
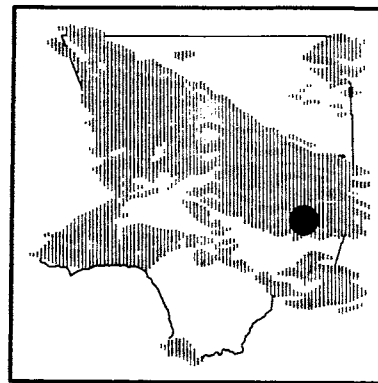

RECORDER- continuous water stage.

METHOD OF MEASUREMENTS- weir formula with gage height observation.

DRAINAGE AREA- none.

LOCATION- on the concrete conduit which diverts from San Gabriel Dam, 160 feet below the Dam.

REGULATION- regulated in section.

CONTROL- 25-foot concrete weir.

LENGTH OF RECORD- February 26, 1933, to date.

REMARKS- approximate capacity 95 second- feet.

WATER YEAR 1989 - 90
(DISCHARGE IN SEC-FT.)

STATION NO. : F250-R

DRAINAGE AREA : NONE

		OCTOBER	NOVEMBER	DECEMBER	JANUARY	FEBRUARY	MARCH	APRIL	MAY	JUNE	JULY	AUGUST	SEPTEMBER
WATER YEAR 89-90	MEAN	6.2	12.5	12.4	14.9	13.2	26.5	25.1	32.3	31.3	32.3	33.4	21.9
	MAX.	12.4	13.1	12.7	31.4	15.2	32.3	32.3	33.0	32.7	34.8	33.7	33.5
	MIN.	0.0	9.3	12.4	12.4	12.4	13.8	0.0	31.2	28.5	31.0	33.2	15.1
TOTAL AF		382.0	746.0	764.0	919.0	733.0	1628.0	1495.0	1985.0	1862.0	1986.0	2056.0	1303.0

VERDUGO WASH at Estelle Avenue STATION NO. F252-R

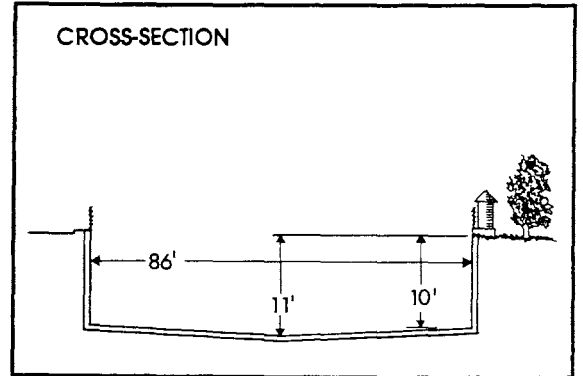
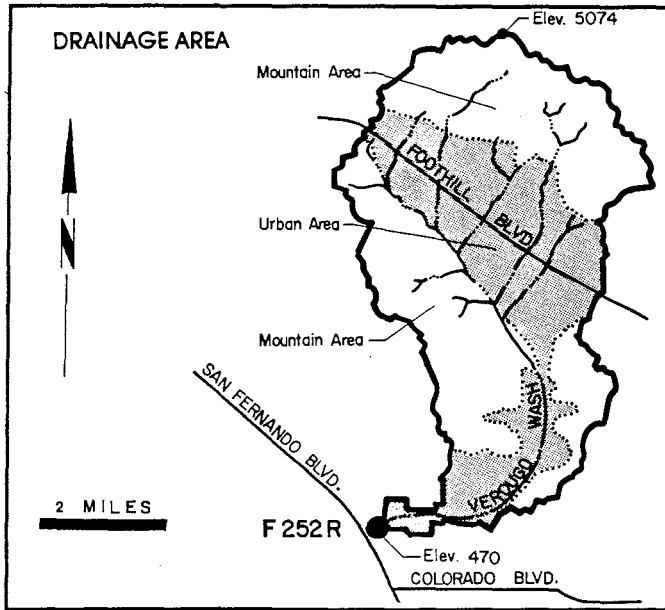
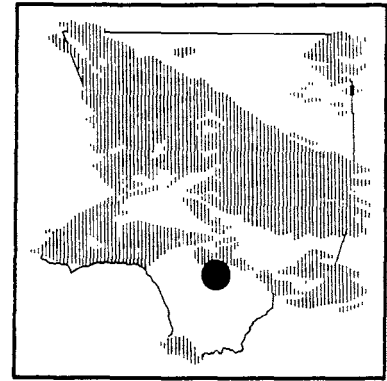

RECORD: continuous water stage.
METHOD OF MEASUREMENTS: wading or from Concord Street Bridge.
DRAINAGE AREA: 26.8 square miles.
LOCATION: 800.0 feet east of San Fernando Road, 2.0 miles northwest of Glendale.
REGULATION: partially regulated by several debris basins.
CHANNEL: concrete, rectangular in section.
CONTROL: channel forms control.
LENGTH OF RECORD: December 2, 1935 to date.

WATER YEAR 1989 - 90
(DISCHARGE IN SEC.-FT.)

STATION NO. : F252-R

DRAINAGE AREA : 26.80 SQ. MI.

		OCTOBER	NOVEMBER	DECEMBER	JANUARY	FEBRUARY	MARCH	APRIL	MAY	JUNE	JULY	AUGUST	SEPTEMBER
WATER YEAR 89-90	MEAN	3.2	6.6	2.5	20.3	23.1	1.5	3.4	5.1	0.8	1.2	0.8	1.2
	MAX.	29.0	113.0	3.6	212.0	474.0	4.5	24.0	130.0	1.6	2.2	1.6	1.7
	MIN.	1.5	1.7	1.7	1.5	1.0	1.0	1.0	0.0	0.1	0.7	0.4	0.7
TOTAL AF		197.0	390.0	156.0	1247.0	1284.0	89.7	203.0	315.0	47.4	71.0	48.4	71.8

SAN GABRIEL RIVER below Valley Boulevard STATION NO. F261C-R

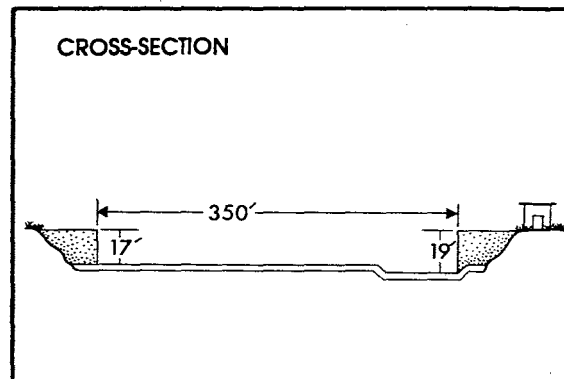
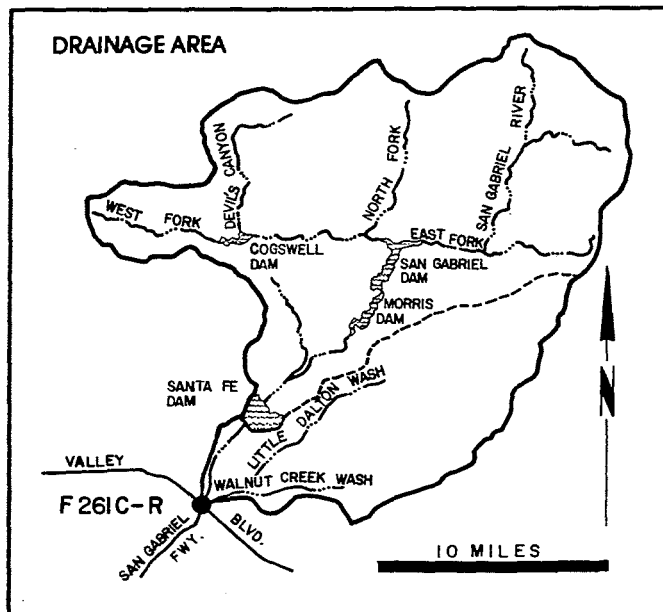
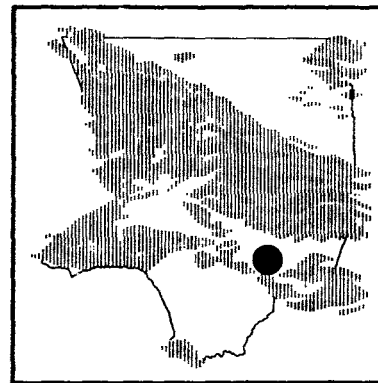

RECORDER- continuous water stage.
 METHOD OF MEASUREMENTS- wading.
 DRAINAGE AREA- 118.0 square miles (excludes area above Santa Fe Dam).
 LOCATION- 1,150.0 feet below Valley Boulevard, 2.5 miles east of El Monte.
 REGULATION- partly regulated by Santa Fe, Big Dalton, Puddingstone Dams.
 CHANNEL- sand and gravel bottom with rip-rap side slopes; trapezoidal section.
 CONTROL- concrete stabilizer with low-flow notch.
 LENGTH OF RECORD- at Station F261-R March 11, 1937 to September 30, 1941. at Station F261B-R October 1, 1941 to April 23, 1946. at Station F261C-R November 29, 1960 to date.
 REMARKS- flows may include imported water originating at Metropolitan Water District outlets at San Dimas Canyon and below San Bernardino Road.

WATER YEAR 1989 - 90 (DISCHARGE IN SEC.-FT.)

STATION NO. : F261C-R

DRAINAGE AREA : 118.00 SQ. MI.

		OCTOBER	NOVEMBER	DECEMBER	JANUARY	FEBRUARY	MARCH	APRIL	MAY	JUNE	JULY	AUGUST	SEPTEMBER
WATER YEAR 89-90	MEAN	80.0	99.9	2.1	4.6	128.0	123.0	155.0	28.4	21.0	22.8	22.0	6.8
	MAX.	161.0	226.0	57.5	46.5	1450.0	192.0	263.0	522.0	28.6	30.6	27.8	9.7
	MIN.	0.0	0.0	0.0	0.0	0.0	0.0	23.3	0.0	0.0	9.6	0.0	0.1
TOTAL AF		4920.0	5941.0	132.0	284.0	7086.0	7591.0	9202.0	1747.0	1250.0	1400.0	1356.0	402.0

SAN GABRIEL RIVER above Florence Avenue STATION NO. F262B-R

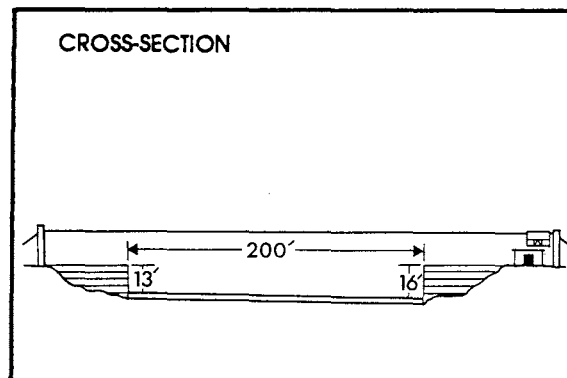
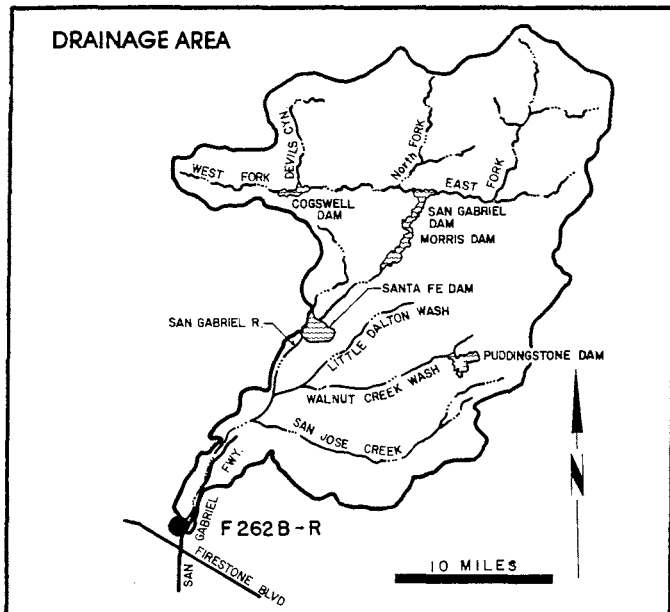
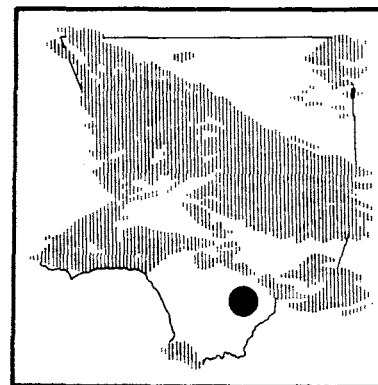

RECORDER- continuous water stage.

METHOD OF MEASUREMENTS- wading or from cable car.

DRAINAGE AREA- 215.8 square miles (excludes area above Santa Fe Dam).

LOCATION- 1,400 feet above Florence Avenue, 2.0 miles east of Downey.

REGULATION- partially regulated by Cogswell, San Gabriel, Morris, Santa Fe, Big Dalton, San Dimas, Puddingstone Diversion, Puddingstone, Live Oak, Thompson Creek and Whittier Narrows Dams, several debris basins, MWD outlets, and several spreading grounds.

CHANNEL- sand bottom with rip-rap slopes, trapezoidal section.

CONTROL- concrete stabilizer.

LENGTH OF RECORD- at Station F267-R February 27, 1937 to September 30, 1967. at Station F262B-R August 6, 1968 to date.

REMARKS- no record during 1967-1968 season due to channel construction.

WATER YEAR 1989 - 90
(DISCHARGE IN SEC-FT.)

STATION NO. : F262B-R

DRAINAGE AREA : 215.80 SQ. MI.

		OCTOBER	NOVEMBER	DECEMBER	JANUARY	FEBRUARY	MARCH	APRIL	MAY	JUNE	JULY	AUGUST	SEPTEMBER
WATER YEAR 89-90	MEAN	0.0	0.0	0.0	0.0	1.2	0.0	0.0	0.0	0.0	0.0	0.0	0.0
	MAX.	0.1	0.0	0.0	0.0	32.0	0.0	0.0	0.0	0.0	0.0	0.0	0.0
	MIN.	0.0	0.0	0.0	0.0	0.0	0.0	0.0	0.0	0.0	0.0	0.0	0.0
TOTAL AF		0.3	0.0	0.0	0.0	64.5	0.0	0.0	0.0	0.0	0.0	0.0	0.0

SAN GABRIEL RIVER

below San Gabriel River Parkway

STATION NO. F263C-R

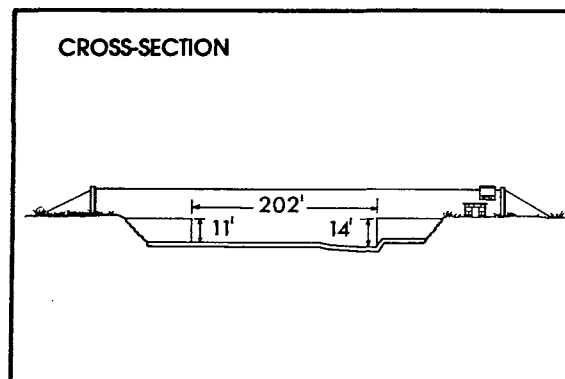
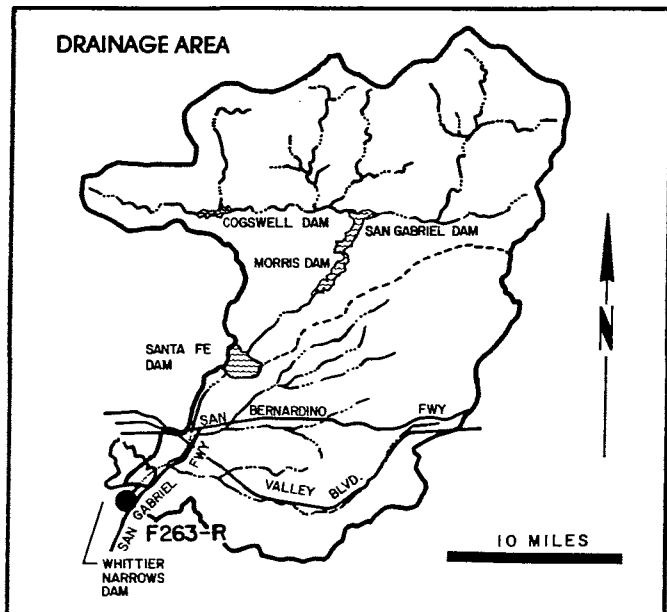
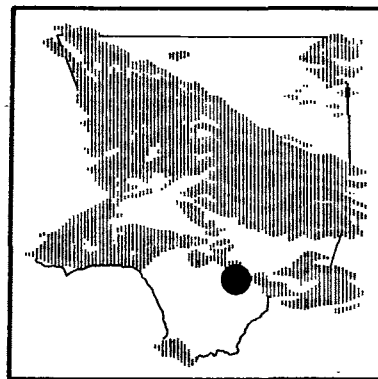

RECORDER- continuous water stage.

METHOD OF MEASUREMENTS- wading or from cable car.

DRAINAGE AREA- 206.3 square miles (excludes area above Santa Fe Dam).

LOCATION- 462.0 feet below San Gabriel River Parkway, 1.4 miles northeast of Pico Rivera.

REGULATION- partly regulated by Santa Fe, Big Dalton, Puddingstone Diversion, Puddingstone, and Thompson Creek Dams. Flows may include imported water from several Metropolitan Water District outlets. Water is at times diverted to the Zone I ditch upstream of Whittier Narrows Dam.

CHANNEL- rip-rap slopes with sand bottom trapezoidal section.

CONTROL- concrete stabilizer.

LENGTH OF RECORD - at Station F263-R February 4, 1937 to March 6, 1952. at Station F263B-R March 6, 1952 to August 9, 1968. at Station F263C-R August 9, 1968 to date.

WATER YEAR 1989 - 90 (DISCHARGE IN SEC.-FT.)

STATION NO. : F263C-R

DRAINAGE AREA : 206.30 SQ. MI.

		OCTOBER	NOVEMBER	DECEMBER	JANUARY	FEBRUARY	MARCH	APRIL	MAY	JUNE	JULY	AUGUST	SEPTEMBER
WATER YEAR 89-90	MEAN	73.0	16.9	7.8	25.0	59.5	77.2	60.1	13.4	27.2	0.3	52.3	65.0
	MAX.	166.0	141.0	34.2	145.0	612.0	158.0	134.0	109.0	76.6	4.6	114.0	188.0
	MIN.	9.3	0.0	0.0	0.0	0.0	0.0	0.0	0.0	0.0	0.0	0.0	5.6
TOTAL AF		4487.0	1005.0	480.0	1536.0	3305.0	4745.0	3578.0	821.0	1619.0	16.1	3218.0	3869.0

SIERRA MADRE WASH at Highland Oaks Avenue STATION NO. F267B-R

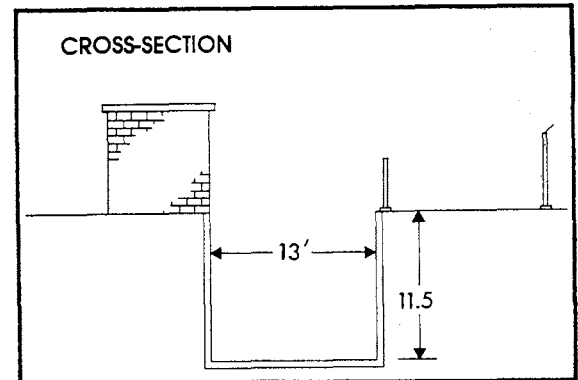
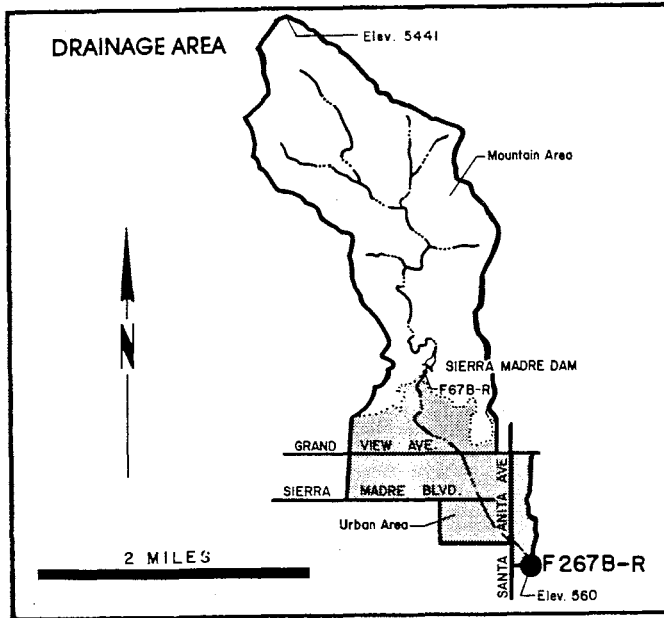
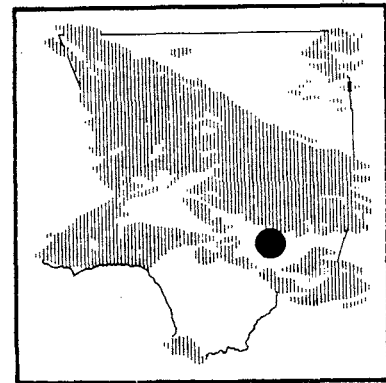

RECORDER- 15 minute punched tape.

METHOD OF MEASUREMENTS- low flows measured by wading. High flows measured from upstream end of conduit 50 feet below station.

DRAINAGE AREA- 3.8 square miles.

LOCATION- on the south bank of the channel 50 feet above Highland Oaks Avenue, one and one-half miles southeast of Sierra Madre.

REGULATION- partially regulated by Sierra Madre Dam. Usual regulation affects high flows only.

DIVERSIONS- underground and surface flows developed and diverted by Sierra Madre Water Department. Flow also diverted about one mile above station for spreading in Sierra Madre Spreading Grounds.

CHANNEL-rectangular concrete 13 feet wide and 11.5 feet deep.

LENGTH OF RECORD- see station summary.

WATER YEAR 1989 - 90 (DISCHARGE IN SEC.-FT.)

STATION NO. : F267B-R

DRAINAGE AREA : 3.80 SQ. MI.

		OCTOBER	NOVEMBER	DECEMBER	JANUARY	FEBRUARY	MARCH	APRIL	MAY	JUNE	JULY	AUGUST	SEPTEMBER
WATER YEAR 89-90	MEAN	0.2	0.3	0.3	0.6	0.5	0.0	0.1	0.3	0.0	0.0	0.0	0.0
	MAX.	0.4	2.1	0.5	8.7	9.3	0.2	1.6	5.0	0.1	0.1	0.1	0.2
	MIN.	0.1	0.1	0.1	0.0	0.0	0.0	0.0	0.0	0.0	0.0	0.0	0.0
TOTAL AF		9.7	15.9	16.9	37.3	26.4	1.2	8.5	17.9	1.4	2.4	0.2	1.0

DALTON WASH at Merced Avenue STATION NO. F274B-R

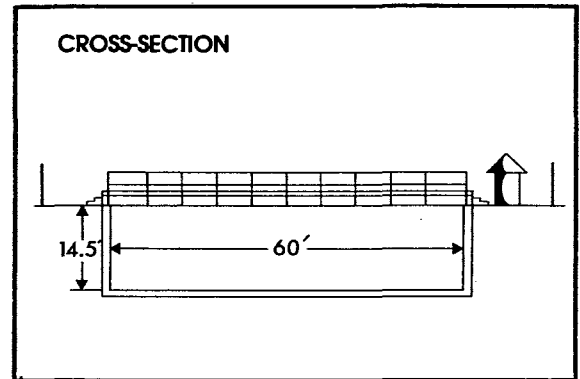
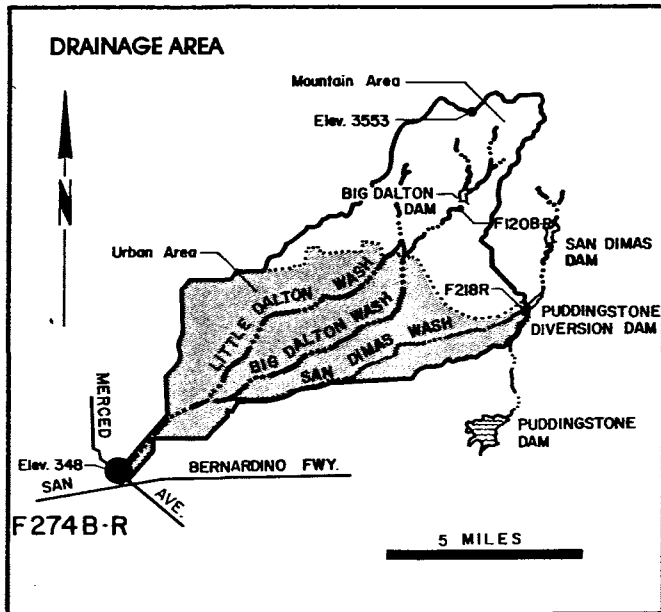
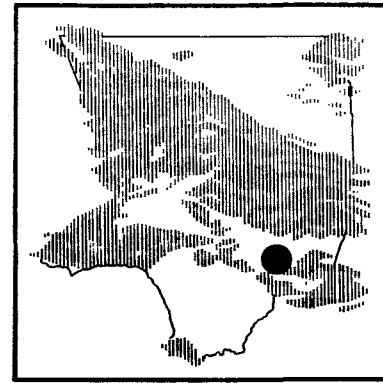

RECORDER- 15 minute punched tape.

METHOD OF MEASUREMENTS- low flows measured by wading. High flows measured from footbridge 100 feet upstream from station.

DRAINAGE AREA- 36.0 square miles, not including the area above Puddingstone Diversion Dam.

LOCATION- on the west bank and upstream of Merced Avenue about 150 feet, about one-half mile above the junction with Walnut Wash and about one mile south of Baldwin Park.

REGULATION- partly regulated by Big Dalton Dam, San Dimas Dam, Puddingstone Diversion Dam, Big Dalton Spreading Grounds, Little Dalton Spreading Grounds, Big Dalton Debris Basin, Little Dalton Debris Basin, and Irwindale Spreading Grounds.

REMARKS- flow may include imported water originating at San Dimas.

WATER YEAR 1989 - 90 (DISCHARGE IN SEC.-FT.)

STATION NO. : F274B-R

DRAINAGE AREA : 36.00 SQ. MI.

		OCTOBER	NOVEMBER	DECEMBER	JANUARY	FEBRUARY	MARCH	APRIL	MAY	JUNE	JULY	AUGUST	SEPTEMBER
WATER YEAR 89-90	MEAN	69.7	95.4	1.7	7.3	68.6	131.0	147.0	24.8	26.5	29.6	31.8	31.8
	MAX.	151.0	157.0	40.1	52.5	568.0	221.0	214.0	252.0	36.5	38.5	42.8	43.1
	MIN.	0.3	0.2	0.2	0.6	0.8	0.7	21.0	1.2	1.7	21.8	25.3	24.4
TOTAL AF		4285.0	5675.0	105.0	447.0	3812.0	8043.0	8752.0	1525.0	1578.0	1819.0	1957.0	1892.0

LOS CERRITOS CHANNEL at Stearns Street STATION NO. F279C-R

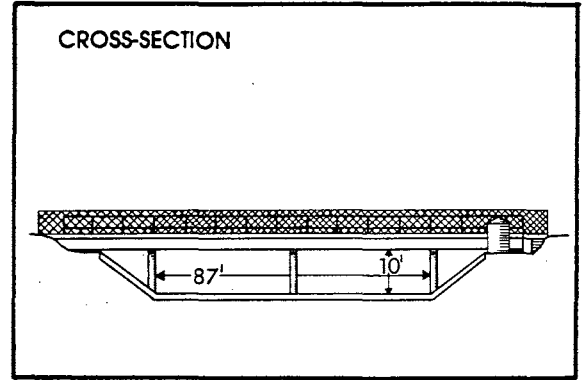
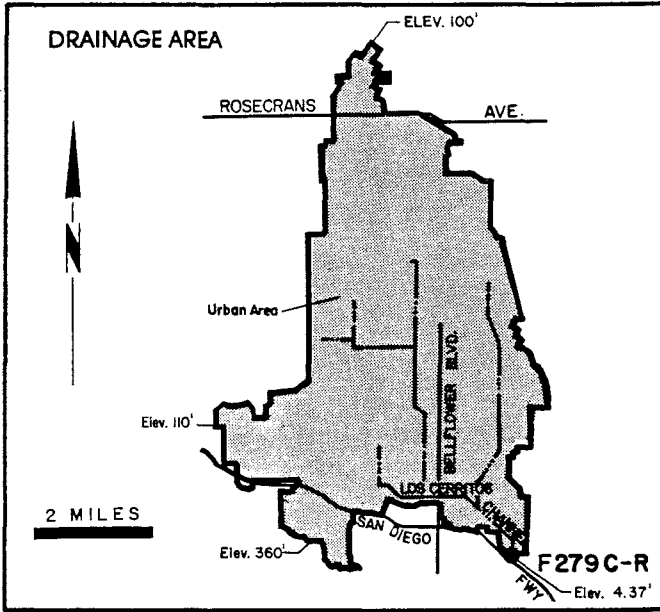
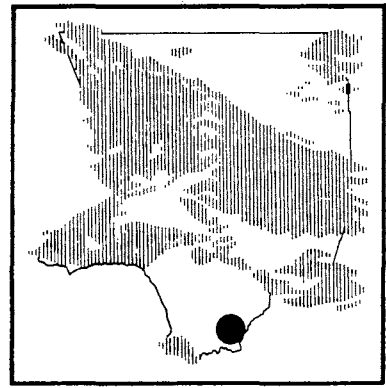

RECORDER- continuous water stage.
 METHOD OF MEASUREMENTS- wading or from bridge.
 DRAINAGE AREA- 25.6 square miles.
 LOCATION- upstream of Stearns Street, Long Beach.
 REGULATION- none.
 CHANNEL- concrete, trapezoidal in section.
 CONTROL- channel forms control.
 LENGTH OF RECORD- at Station F279-R November 23, 1942 to January 1, 1949. at Station F279B-R January 1, 1949 to May 26, 1955. at Station F279C-R October 26, 1955 to date.
 REMARKS- station not in service May 26, 1955 to October 26, 1955 due to channel construction.

WATER YEAR 1989 - 90 (DISCHARGE IN SEC.-FT.)

STATION NO. : F279C-R

DRAINAGE AREA : 25.60 SQ. MI.

		OCTOBER	NOVEMBER	DECEMBER	JANUARY	FEBRUARY	MARCH	APRIL	MAY	JUNE	JULY	AUGUST	SEPTEMBER
WATER YEAR 89-90	MEAN	4.0	2.5	1.7	12.4	21.7	2.0	6.0	9.1	0.9	1.1	1.4	1.7
	MAX.	68.4	30.9	11.1	115.0	474.0	20.2	145.0	255.0	2.7	3.6	2.6	2.9
	MIN.	1.3	0.7	1.0	0.5	0.3	0.4	0.5	0.6	0.6	0.5	1.2	1.3
TOTAL AF		243.0	148.0	106.0	759.0	1206.0	121.0	357.0	560.0	50.8	65.1	86.3	100.0

SANTA FE CHANNEL

below Santa Fe Dam
STATION NO. F280-R

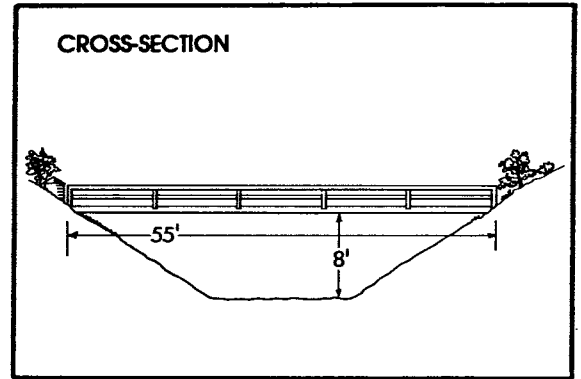
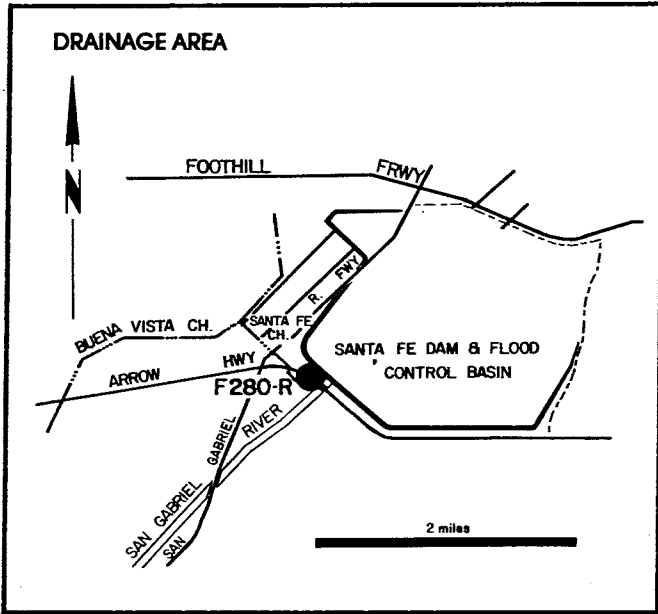
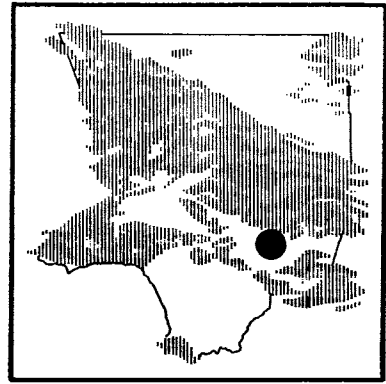

RECORDER- continuous water stage.
 METHOD OF MEASUREMENTS- wading or from footbridge.
 DRAINAGE AREA- controlled.
 LOCATION- 400.0 feet downstream of Santa Fe Dam outlet and 1.5 miles north of Baldwin Park.
 REGULATION- flow regulated by five gates of stilling basin outlet of Santa Fe Dam.
 CHANNEL- sand and gravel, natural section.
 CONTROL- concrete stabilizer.
 LENGTH OF RECORD- at Station F280-S October 1, 1942 to May 12, 1944. at Station F280-R May 12, 1944 to date.

WATER YEAR 1989 - 90 (DISCHARGE IN SEC.-FT.)

STATION NO. : F280-R

DRAINAGE AREA : CONTROLLED

		OCTOBER	NOVEMBER	DECEMBER	JANUARY	FEBRUARY	MARCH	APRIL	MAY	JUNE	JULY	AUGUST	SEPTEMBER
WATER YEAR 89-90	MEAN	0.0	0.0	0.0	0.0	0.0	0.0	0.0	0.0	0.0	0.0	0.0	0.0
	MAX.	0.0	0.0	0.0	0.0	0.0	0.0	0.0	0.0	0.0	0.0	0.0	0.0
	MIN.	0.0	0.0	0.0	0.0	0.0	0.0	0.0	0.0	0.0	0.0	0.0	0.0
TOTAL AF		0.0	0.0	0.0	0.0	0.0	0.0	0.0	0.0	0.0	0.0	0.0	0.0

BURBANK-WESTERN ST. DR.

at Riverside Drive
STATION NO. E 285-R

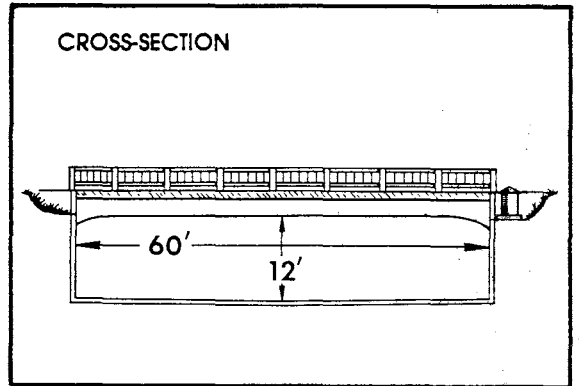
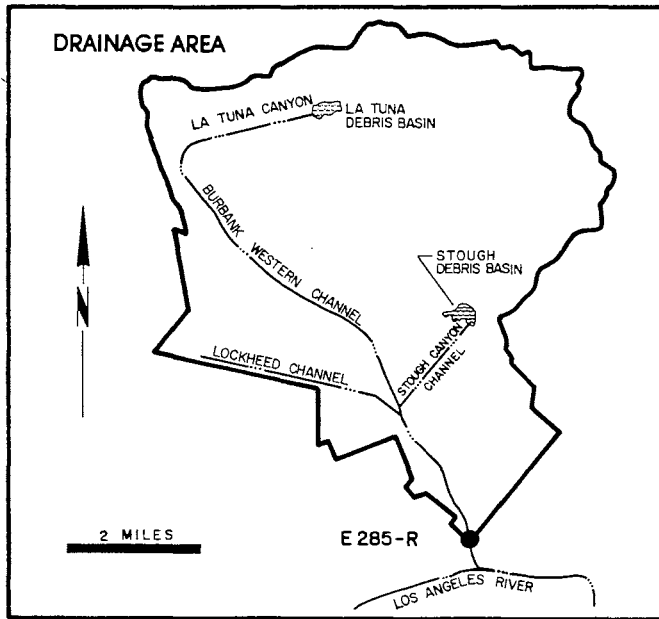
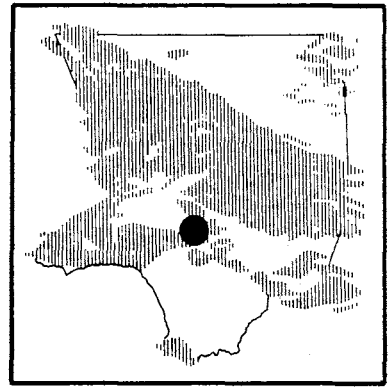

RECORDER- continuous water stage.
 METHOD OF MEASUREMENTS- wading and from bridge.
 DRAINAGE AREA- 25.0 square miles.
 LOCATION- 20.0 feet upstream from Riverside Drive bridge, Glendale.
 REGULATION- Several debris basins on tributaries.
 CHANNEL- concrete, rectangular section.
 CONTROL- channel forms control.
 LENGTH OF RECORD- October 1, 1949 to date.
 REMARKS- operated in cooperation with the USCE.

WATER YEAR 1989 - 90 (DISCHARGE IN SEC-FT.)

STATION NO. : E285-R

DRAINAGE AREA: 25.00 SQ. MI.

		OCTOBER	NOVEMBER	DECEMBER	JANUARY	FEBRUARY	MARCH	APRIL	MAY	JUNE	JULY	AUGUST	SEPTEMBER
WATER YEAR 89-90	MEAN	7.1	8.8	7.3	14.8	24.0	11.0	10.6	9.6	8.4	7.3	7.3	5.2
	MAX.	23.0	40.4	8.3	62.6	253.0	24.9	66.2	83.4	10.1	8.0	30.2	6.0
	MIN.	4.7	5.6	5.6	7.0	7.7	7.4	6.4	5.7	6.2	6.6	6.0	4.1
TOTAL AF		436.0	523.0	448.0	910.0	1334.0	679.0	633.0	589.0	497.0	452.0	451.0	306.0

LOS ANGELES RIVER at Tujunga Avenue STATION NO. F300-R

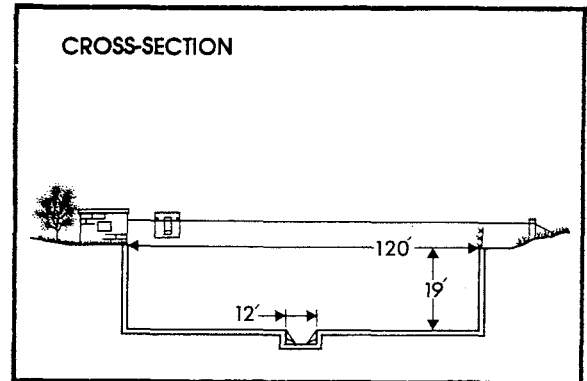
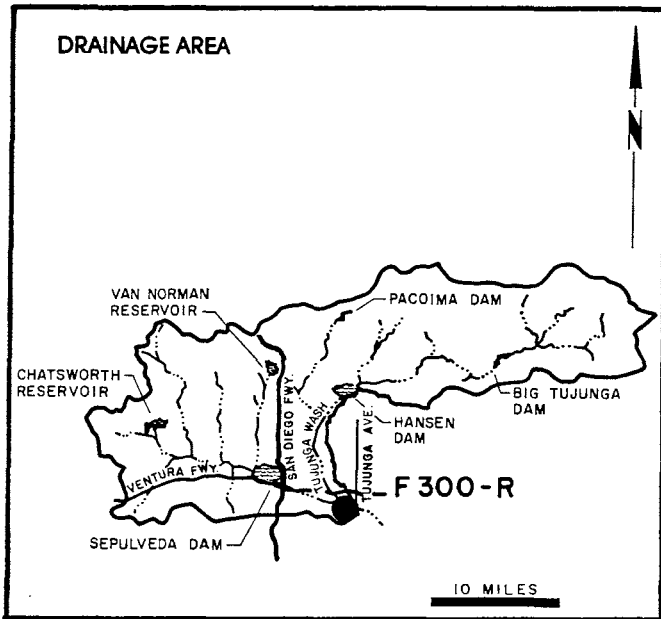
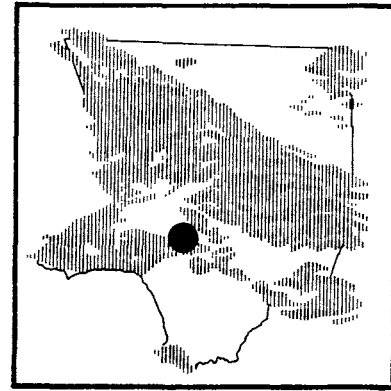

RECORDER- continuous water stage.
 METHOD OF MEASUREMENTS- wading or from cable car.
 DRAINAGE AREA- 401.0 square miles.
 LOCATION- 200.0 feet above Tujunga Avenue bridge, Studio City.
 REGULATION- flow regulated by Sepulveda, Big Tujunga, Hansen, and Pacoima Dams, Lopez Debris Dam, and Project No. 85 Diversion.
 CHANNEL- concrete, rectangular section, 120 feet wide by 19 feet deep.
 CONTROL- channel forms control.
 LENGTH OF RECORD- May 8, 1950, to date.
 REMARKS- subject to diversions at mouth of Big Tujunga and Pacoima Canyons for irrigation, at Big Tujunga, Branford, Hansen, and Pacoima Spreading Grounds.

WATER YEAR 1989 - 90
 (DISCHARGE IN SEC.-FT.)

STATION NO. : F300-R

DRAINAGE AREA : 401.00 SQ. MI.

		OCTOBER	NOVEMBER	DECEMBER	JANUARY	FEBRUARY	MARCH	APRIL	MAY	JUNE	JULY	AUGUST	SEPTEMBER
WATER YEAR 89-90	MEAN	80.8	83.6	68.2	152.0	209.0	72.5	83.2	87.9	67.5	72.2	82.6	72.2
	MAX.	402.0	504.0	79.4	1410.0	2910.0	151.0	358.0	750.0	73.4	76.6	224.0	90.0
	MIN.	64.2	64.3	62.1	61.5	63.5	61.8	64.4	62.3	55.6	60.5	71.1	67.3
TOTAL AF		4967.0	4975.0	4195.0	9331.0	11623.0	4460.0	4952.0	5402.0	4016.0	4441.0	5080.0	4297.0

SAWTELLE-WESTWOOD CHANNEL

above Culver Boulevard

STATION NO. F301-R

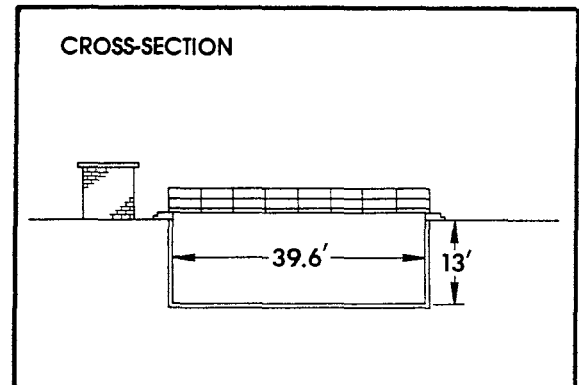
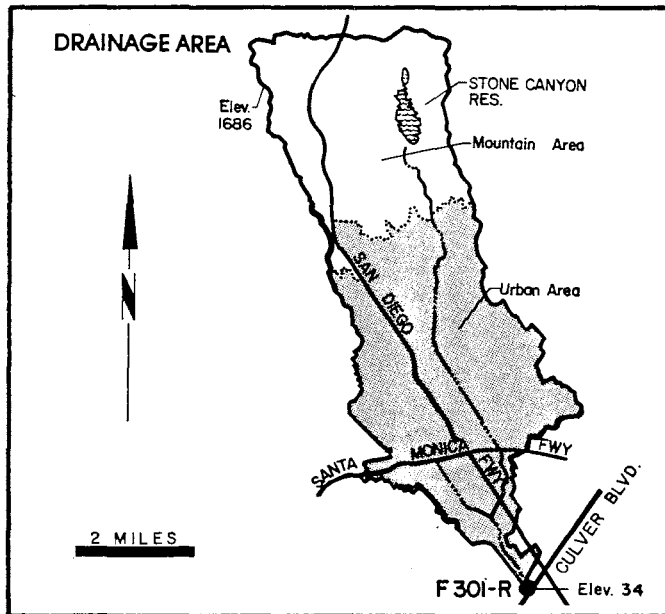
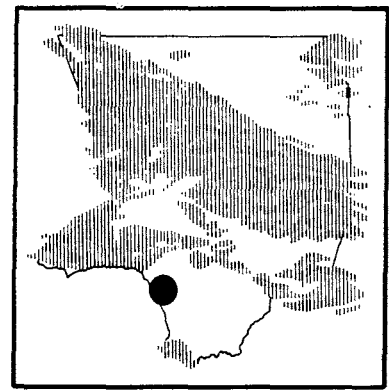

RECORDER- 15 minute punched tape.

METHOD OF MEASUREMENTS- low flows measured by wading. High flows measured from footbridge at station.

DRAINAGE AREA- 22.96 square miles.

LOCATION- on the south channel wall, 141 feet above Culver Boulevard bridge about one and one half miles southwest of Culver City.

REGULATION- Stone Canyon Reservoir, Southern California Water Company spills flow up to 5.0 second-feet into Sawtelle-Westwood Channel above Chamock Road for short periods nearly every day.

CHANNEL- rectangular concrete channel 40 feet wide and 13 feet deep.

CONTROL- channel forms control.

LENGTH OF RECORD- see station summary.

WATER YEAR 1989 - 90 (DISCHARGE IN SEC.-FT.)

STATION NO. : F301-R

DRAINAGE AREA : 22.96 SQ. MI.

		OCTOBER	NOVEMBER	DECEMBER	JANUARY	FEBRUARY	MARCH	APRIL	MAY	JUNE	JULY	AUGUST	SEPTEMBER
WATER YEAR 89-90	MEAN	7.4	7.2	5.9	13.1	51.5	4.2	7.4	9.5	5.4	6.4	4.6	4.3
	MAX.	55.7	81.5	12.1	129.0	1100.0	9.1	38.1	161.0	8.7	9.5	7.6	5.5
	MIN.	2.6	2.6	3.1	2.7	2.6	2.6	2.4	0.9	4.2	4.2	4.2	3.6
TOTAL AF		453.0	430.0	363.0	808.0	2860.0	255.0	443.0	584.0	320.0	392.0	282.0	257.0

WALNUT CREEK above Puente Avenue STATION NO. F304-R

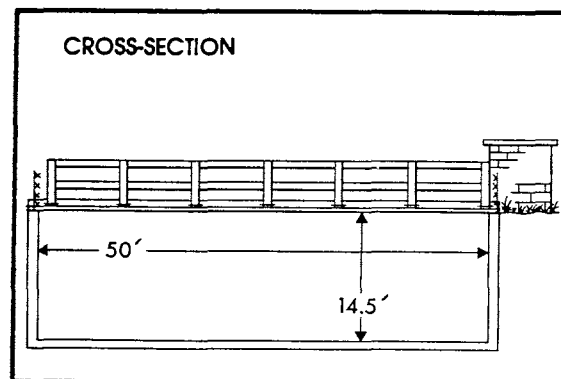
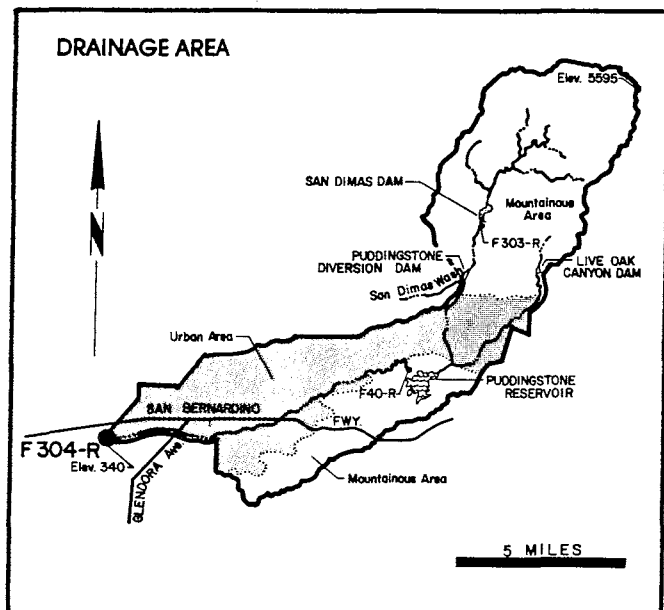
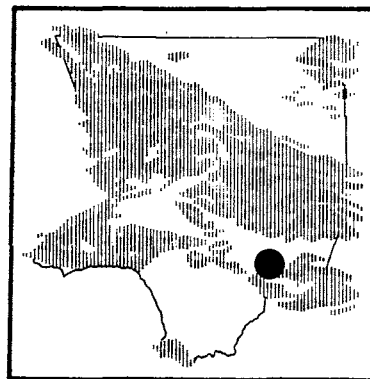

RECORDER- continuous water stage.
 METHOD OF MEASUREMENTS- wading or from footbridge.
 DRAINAGE AREA- 57.6 square miles.
 LOCATION- 845.0 feet upstream of Puente Avenue bridge, Baldwin Park.
 REGULATION- partially regulated by San Dimas, Puddingstone Diversion, Puddingstone, and Live Oak Dams.
 CHANNEL- concrete, rectangular in section.
 CONTROL- channel forms control.
 LENGTH OF RECORD- October 14, 1952 to April 11, 1961, January 3, 1962 to date.
 REMARKS- no record during April 11, 1961 to January 3, 1962 due to channel construction.

WATER YEAR 1989 - 90
 (DISCHARGE IN SEC.-FT.)

STATION NO. : F304-R

DRAINAGE AREA : 57.60 SQ. MI.

		OCTOBER	NOVEMBER	DECEMBER	JANUARY	FEBRUARY	MARCH	APRIL	MAY	JUNE	JULY	AUGUST	SEPTEMBER
WATER YEAR 89-90	MEAN	1.4	1.5	0.6	9.1	7.8	0.3	4.0	9.9	0.0	0.1	0.0	0.0
	MAX.	21.4	24.6	14.4	75.5	63.4	5.2	74.5	244.0	0.3	1.3	0.1	0.2
	MIN.	0.0	0.0	0.0	0.1	0.0	0.0	0.0	0.0	0.0	0.0	0.0	0.0
TOTAL AF		85.9	89.5	36.1	560.0	430.0	16.3	236.0	606.0	1.0	4.0	0.2	0.6

SAN JOSE CHANNEL above Workman Mill Road STATION NO. F312-R

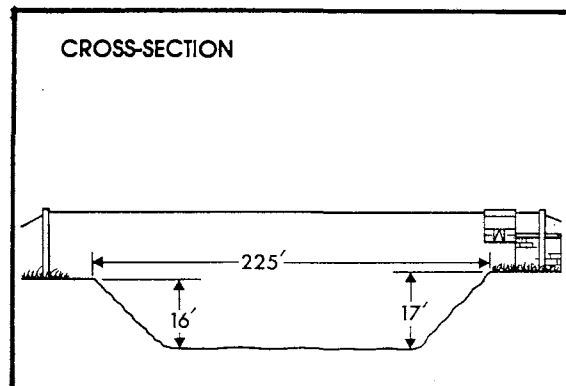
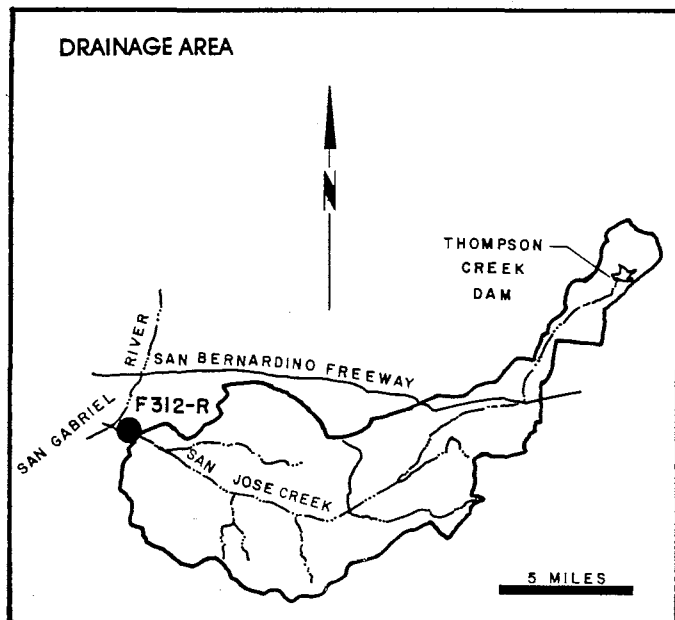
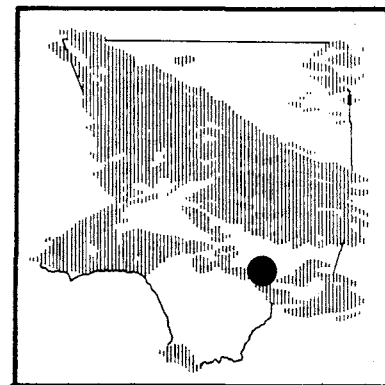

RECORDER- continuous water stage.

METHOD OF MEASUREMENTS- wading or from cable car.

DRAINAGE AREA- 83.4 square miles.

LOCATION- 1,650 feet above Workman Mill Road, 3.0 miles southeast of El Monte.

REGULATION- partially regulated by Thompson Creek Dam and Pomona Sewage Treatment Plant.

CHANNEL- grouted rip-rap side slopes with natural bottom, trapezoidal section.

CONTROL- rock stabilizer.

LENGTH OF RECORD- September 13, 1955 to date.

WATER YEAR 1989 - 90 (DISCHARGE IN SEC-FT.)

STATION NO. : F312-R

DRAINAGE AREA : 83.40 SQ. MI.

		OCTOBER	NOVEMBER	DECEMBER	JANUARY	FEBRUARY	MARCH	APRIL	MAY	JUNE	JULY	AUGUST	SEPTEMBER
WATER YEAR 89-90	MEAN	22.9	19.6	15.2	105.0	216.0	143.0	95.1	46.8	85.3	31.9	66.9	133.0
	MAX.	253.0	206.0	91.3	555.0	3060.0	179.0	278.0	923.0	99.1	77.2	138.0	142.0
	MIN.	9.6	10.1	9.9	10.2	14.7	19.3	7.8	8.9	72.1	9.8	9.3	127.0
TOTAL AF		1410.0	1167.0	933.0	6430.0	12011.0	8770.0	5661.0	2879.0	5075.0	1959.0	4116.0	7912.0

ARCADIA WASH below Grand Avenue STATION NO. F 317-R

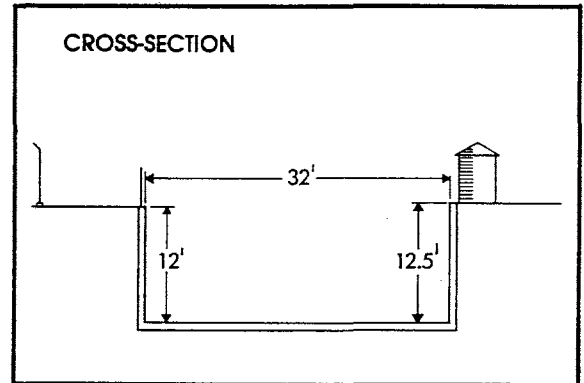
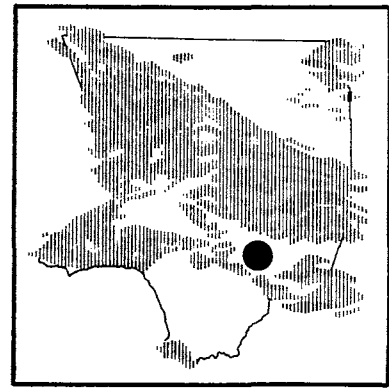
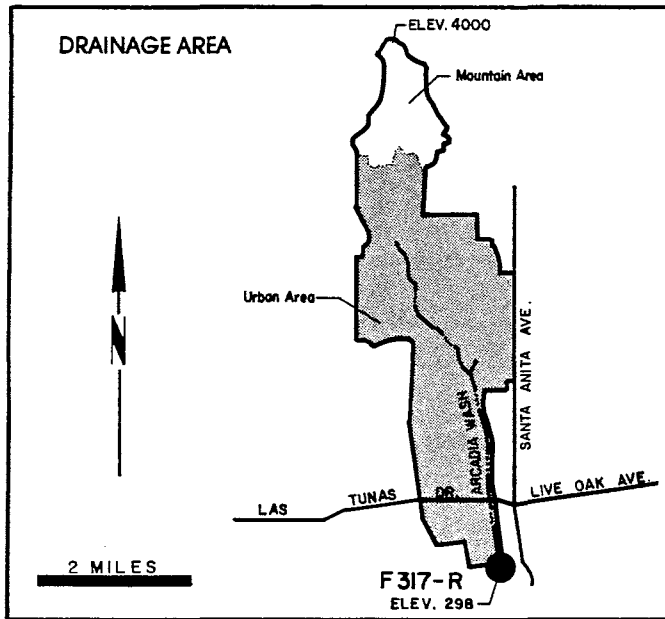

RECORDER- 15 minute punched tape.

METHOD OF MEASUREMENTS- low flows measured by wading. High flows measured from upstream side of Grand Avenue bridge.

DRAINAGE AREA- 8.5 square miles.

LOCATION- on the west wall of Arcadia Wash about 75 feet downstream from centerline of Grand Avenue.

REGULATION- several debris basins located upstream.

CHANNEL- rectangular concrete.

LENGTH OF RECORD- December 12, 1955 to date.

WATER YEAR 1989 - 90 (DISCHARGE IN SEC.-FT.)

STATION NO. : F317-R

DRAINAGE AREA : 8.50 SQ. MI.

		OCTOBER	NOVEMBER	DECEMBER	JANUARY	FEBRUARY	MARCH	APRIL	MAY	JUNE	JULY	AUGUST	SEPTEMBER
WATER YEAR 89-90	MEAN	1.6	1.5	0.2	11.8	12.9	1.6	6.0	3.9	0.5	0.3	1.3	0.6
	MAX.	24.9	36.5	0.4	178.0	243.0	15.5	60.5	113.0	9.5	0.7	5.1	3.5
	MIN.	0.1	0.2	0.2	0.3	0.2	0.2	0.2	0.1	0.1	0.2	0.7	0.1
TOTAL AF		96.8	90.2	14.9	728.0	718.0	96.8	357.0	239.0	30.5	19.2	82.7	32.9

EATON WASH

at Loftus Drive

STATION NO. F318-R

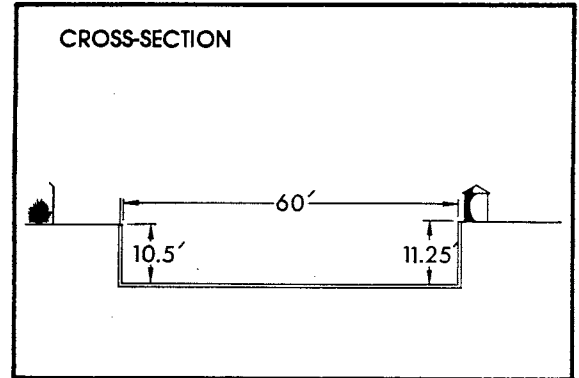
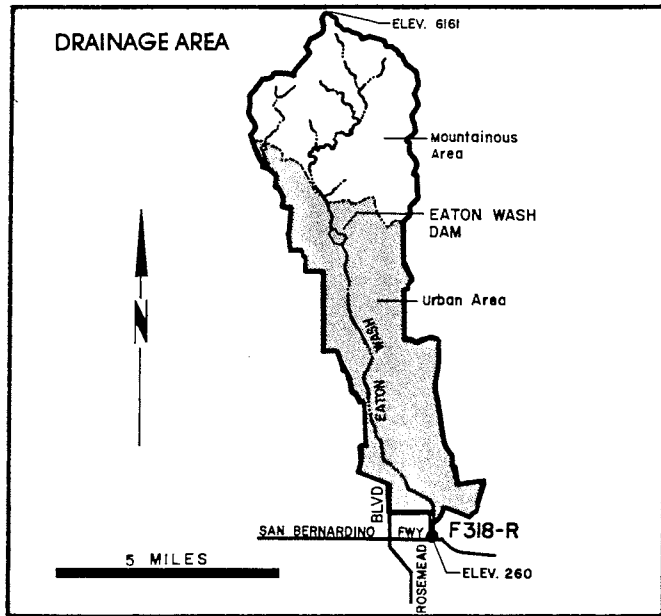
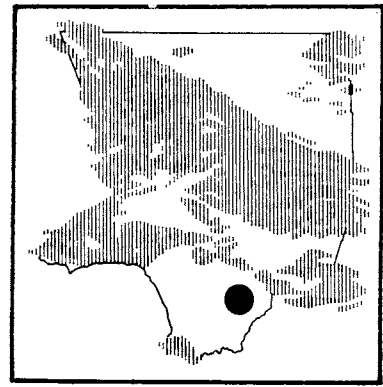

RECORDER- 15 minute punched tape.

METHOD OF MEASUREMENTS- low flows measured by wading. High flows measured from upstream side of East Loftus Drive bridge.

DRAINAGE- 22.8 square miles.

LOCATION- on the west wall of the channel 52 feet above the centerline of East Loftus Drive bridge, 1.3 miles west of El Monte.

REGULATION- partly regulated by Eaton Dam.

DIVERSIONS- the Pasadena Water Department diverts some water just above the mouth of Eaton Canyon. The Flood Control District diverts water to spreading grounds below Eaton Dam and below Huntington Drive.

CHANNEL- rectangular concrete, 60 feet wide, 11.3 feet.

CONTROL- channel forms control.

LENGTH OF RECORD- 1956 to date.

WATER YEAR 1989 - 90

(DISCHARGE IN SEC.-FT.)

STATION NO. : F318-R

DRAINAGE AREA : 22.80 SQ. MI.

		OCTOBER	NOVEMBER	DECEMBER	JANUARY	FEBRUARY	MARCH	APRIL	MAY	JUNE	JULY	AUGUST	SEPTEMBER
WATER YEAR 89-90	MEAN	1.0	1.1	0.2	9.5	17.6	0.7	3.3	4.9	0.1	0.2	0.2	0.1
	MAX.	17.2	27.2	0.2	150.0	383.0	8.3	48.8	149.0	0.2	0.3	1.4	0.3
	MIN.	0.1	0.1	0.1	0.1	0.1	0.1	0.1	0.1	0.1	0.1	0.1	0.1
TOTAL AF		62.5	66.6	9.9	587.0	980.0	44.2	196.0	303.0	7.7	9.7	14.9	7.7

LOS ANGELES RIVER below Wardlow Road STATION NO. F319-R

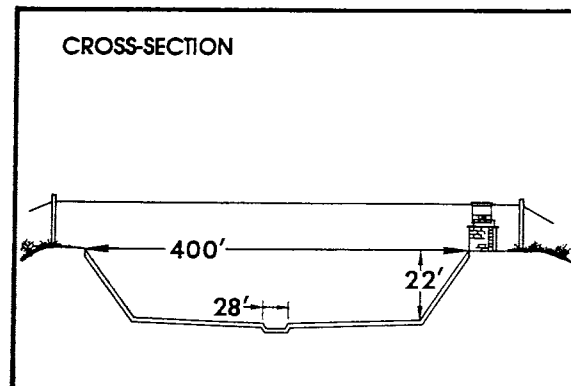
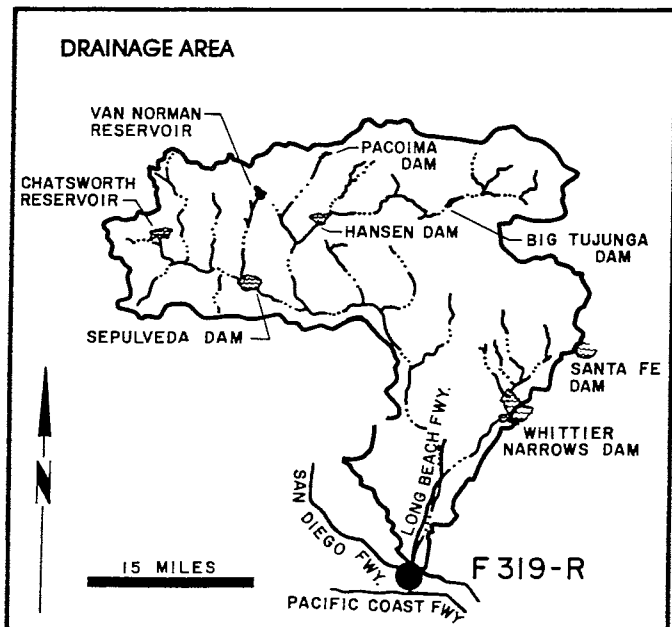
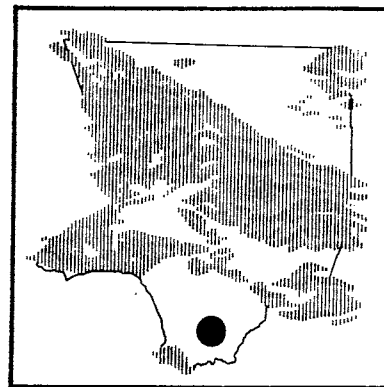

RECORDER- continuous water stage.

METHOD OF MEASUREMENTS- wading or from cable car.

DRAINAGE AREA- 815.0 square miles (excludes area above Santa Fe Dam).

LOCATION- 900.0 feet below Wardlow Road, Long Beach.

REGULATION- flow is subject to the same regulation as Stations F34D-R and P45B-R.

DIVERSIONS- flows diverted to Dominguez Gap Spreading Grounds.

CHANNEL- trapezoidal, concrete, 302.0 feet wide at bottom with 2.25:1 side slopes. Low flow channel 28.0 feet wide by 1.0 foot deep in center of channel.

CONTROL- channel forms control.

LENGTH OF RECORD- at Station F180-R October 31, 1931 to January 13, 1956. at Station F319-R January 13, 1956 to date.

REMARKS- prior to 1931, see Station F36-R.

WATER YEAR 1989 - 90 (DISCHARGE IN SEC.-FT.)

STATION NO. : F319-R

DRAINAGE AREA : 815.00 SQ. MI.

		OCTOBER	NOVEMBER	DECEMBER	JANUARY	FEBRUARY	MARCH	APRIL	MAY	JUNE	JULY	AUGUST	SEPTEMBER
WATER YEAR 89-90	MEAN	160.0	155.0	132.0	262.0	612.0	144.0	195.0	196.0	135.0	132.0	133.0	124.0
	MAX.	674.0	826.0	139.0	1520.0	12100.0	246.0	795.0	2190.0	145.0	139.0	349.0	128.0
	MIN.	130.0	123.0	128.0	115.0	120.0	126.0	143.0	125.0	126.0	126.0	116.0	120.0
TOTAL AF		9834.0	9205.0	8140.0	16128.0	33997.0	8870.0	11597.0	12079.0	8043.0	8091.0	8208.0	7398.0

MINT CANYON CREEK at Finch Avenue STATION NO. F328-R

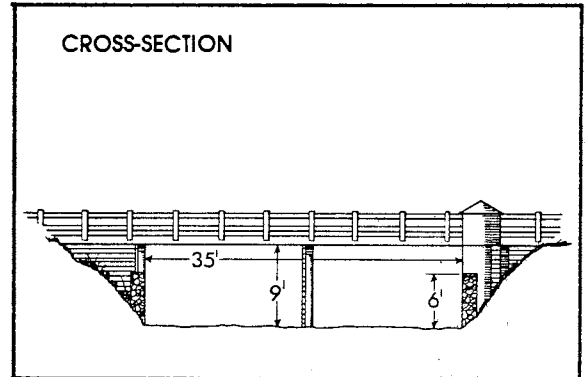
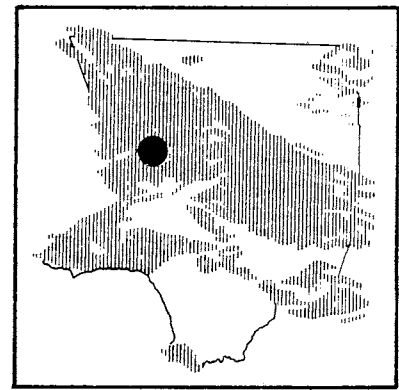
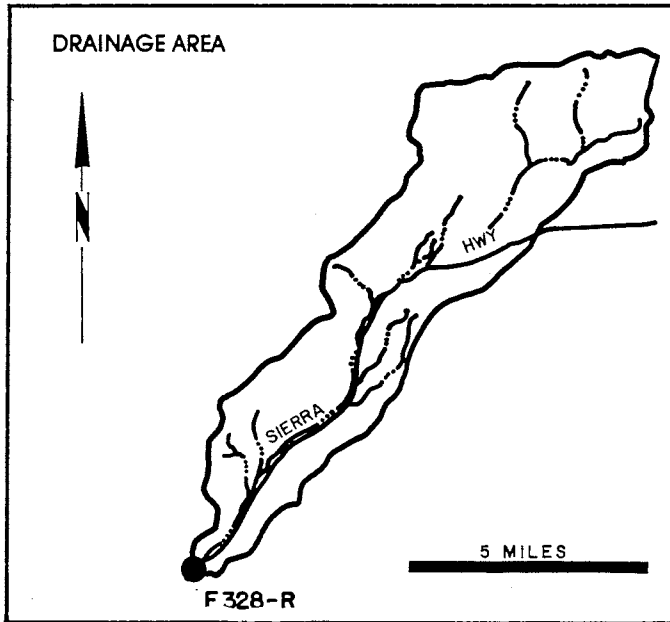

RECORDER- continuous water stage.
 METHOD OF MEASUREMENTS- wading or from bridge.
 DRAINAGE AREA- 26.9 square miles.
 LOCATION- 8.5 miles northeast of Saugus on west end of Finch Avenue bridge.
 REGULATION- none.
 CHANNEL- natural, sand and gravel.
 CONTROL- concrete control at downstream end of bridge.
 LENGTH OF RECORD- October 26, 1956 to date.

WATER YEAR 1989 - 90 (DISCHARGE IN SEC-FT.)

STATION NO. : F328-R

DRAINAGE AREA : 26.90 SQ. MI.

		OCTOBER	NOVEMBER	DECEMBER	JANUARY	FEBRUARY	MARCE	APRIL	MAY	JUNE	JULY	AUGUST	SEPTEMBER
WATER YEAR 89-90	MEAN	0.0	0.0	0.0	2.3	3.8	0.0	0.0	0.0	0.0	0.0	0.0	0.0
	MAX.	0.0	0.0	0.0	24.0	37.8	0.0	0.0	0.0	0.0	0.0	0.0	0.0
	MIN.	0.0	0.0	0.0	0.0	0.0	0.0	0.0	0.0	0.0	0.0	0.0	0.0
TOTAL AF		0.0	0.0	0.0	141.8	211.6	0.0	0.0	0.0	0.0	0.0	0.0	0.0

BRADBURY CHANNEL

below Central Avenue
STATION NO. F329-R

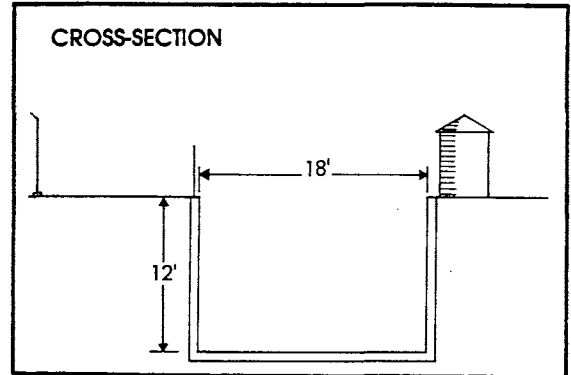
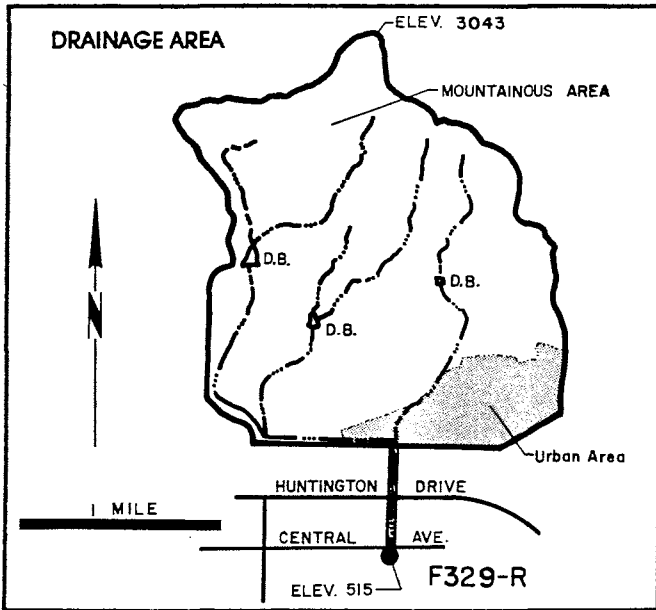
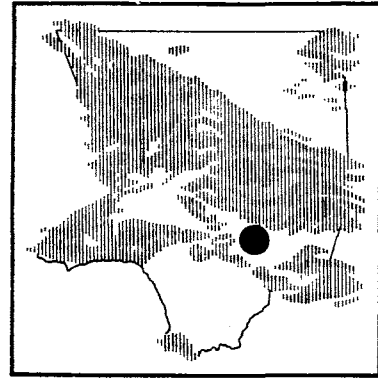

RECORDER- 15 minute punched tape.
 METHOD OF MEASUREMENT- low flows measured by wading. High flows measured from footbridge four feet downstream from recorder.
 DRAINAGE AREA- 3.3 square miles.
 LOCATION- on the east wall of Bradbury Channel, 200 feet downstream from the centerline of Central Avenue, one mile east of Duarte.
 REGULATION- two debris basins located upstream.
 CHANNEL- rectangular concrete, 18 feet wide, 12 feet deep.
 CONTROL- channel forms control.
 LENGTH OF RECORD- June 14, 1957 to present.

WATER YEAR 1989 - 90 (DISCHARGE IN SEC.-FT.)

STATION NO. : F329-R

DRAINAGE AREA : 3.30 SQ. MI.

		OCTOBER	NOVEMBER	DECEMBER	JANUARY	FEBRUARY	MARCH	APRIL	MAY	JUNE	JULY	AUGUST	SEPTEMBER
WATER YEAR 89-90	MEAN	0.8	1.7	3.5	1.8	1.4	0.3	1.1	1.9	0.8	0.5	0.3	0.5
	MAX.	1.8	8.1	7.8	13.0	15.5	1.1	2.2	19.6	3.5	0.9	0.7	0.6
	MIN.	0.3	0.4	0.4	0.1	0.6	0.1	0.5	0.6	0.3	0.3	0.1	0.3
TOTAL AF		49.4	102.0	212.0	109.0	79.3	19.2	61.7	119.0	48.8	31.3	15.9	28.0

RUBIO DIVERSION CHANNEL

below Goosebury Inlet

STATION NO. F338-R

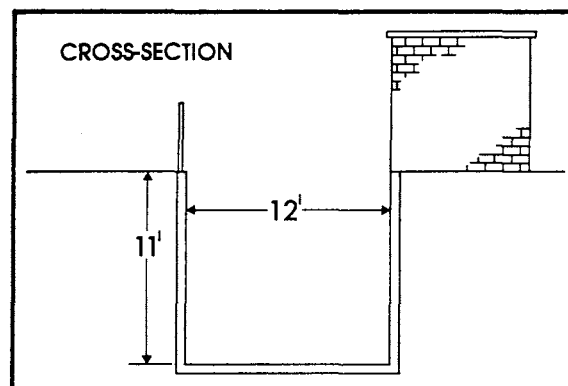
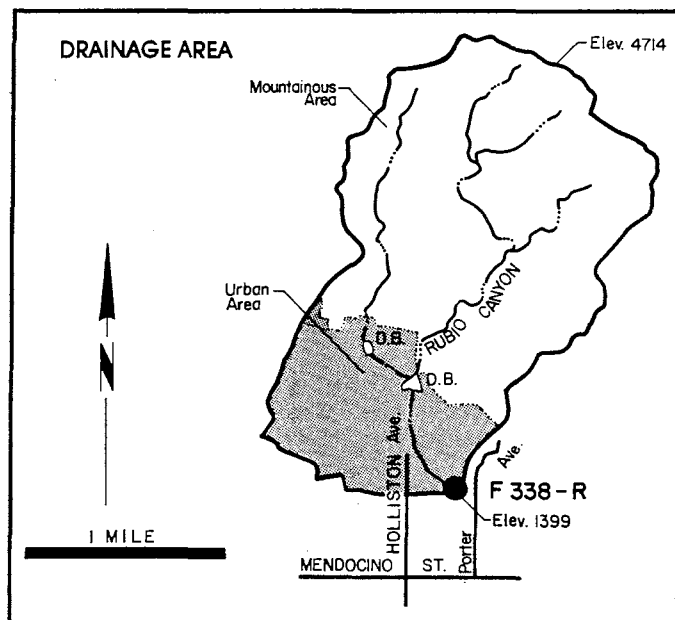
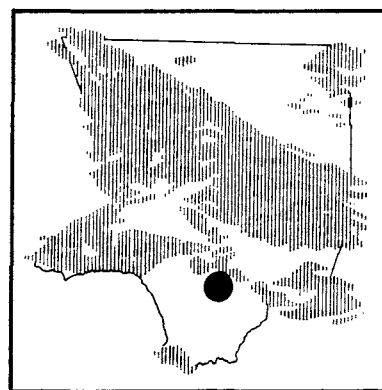

RECORDER- 15 minute punched tape.
 METHOD OF MEASUREMENTS- low flows measured by wading. High flows measured from steel footbridge 27 feet above station.
 DRAINAGE AREA- 2.1 square miles.
 LOCATION- on the north bank, 375 feet upstream of Crest Drive, three and one-half miles northeast of Pasadena.
 REGULATION- flow partially regulated by Rubio and Gooseberry Debris Basins.
 DIVERSIONS- Rubio Canyon Land and Water Association diverts low flows in Rubio Canyon.
 CHANNEL- rectangular concrete, 12 feet wide and 11 feet deep.
 CONTROL- channel forms control.
 LENGTH OF RECORD- December 16, 1959 to date.

WATER YEAR 1989 - 90 (DISCHARGE IN SEC.-FT.)

STATION NO. : F338-R

DRAINAGE AREA : 2.10 SQ. MI.

		OCTOBER	NOVEMBER	DECEMBER	JANUARY	FEBRUARY	MARCH	APRIL	MAY	JUNE	JULY	AUGUST	SEPTEMBER
WATER YEAR 89-90	MEAN	0.2	0.1	0.0	0.6	0.7	0.7	0.9	0.6	0.0	0.0	0.1	0.0
	MAX.	1.3	1.6	0.2	5.2	4.7	1.1	4.1	0.7	0.0	0.0	0.3	0.2
	MIN.	0.0	0.0	0.0	0.0	0.0	0.5	0.6	0.5	0.0	0.0	0.0	0.0
TOTAL AF		9.5	4.0	3.0	36.1	38.7	43.8	56.1	36.9	0.0	0.0	3.2	0.6

BRANFORD STREET CHANNEL

below Sharp Avenue
STATION NO. F342-R

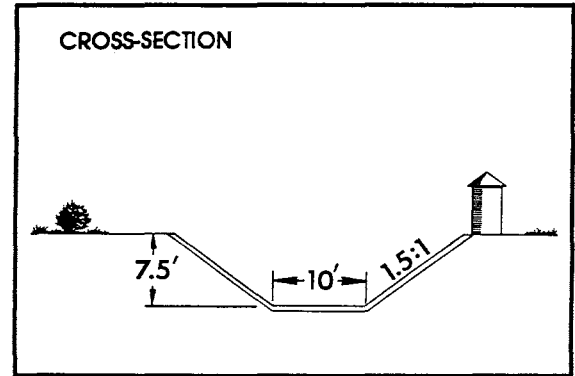
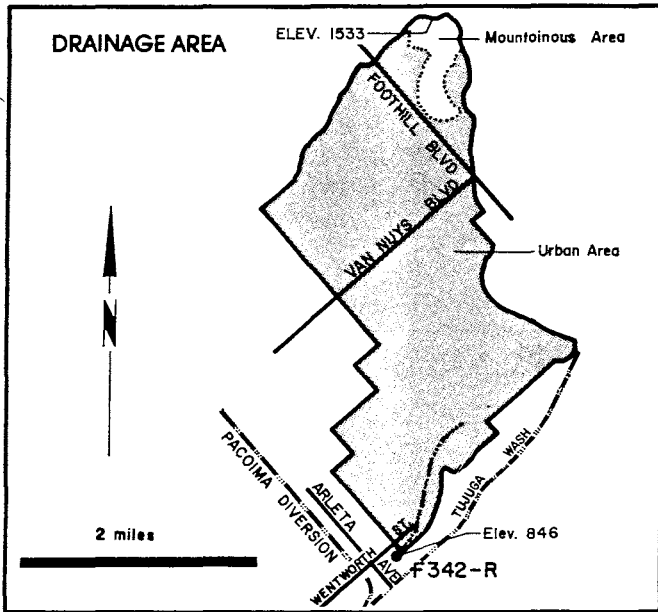
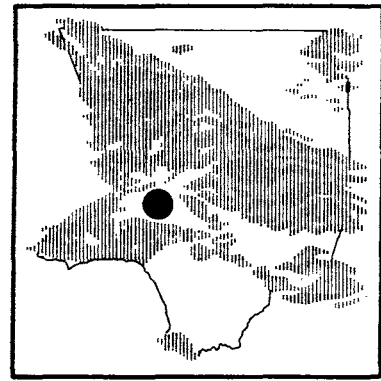

RECORDER- 15 minute punched tape.
 METHOD OF MEASUREMENTS- low flows measured by wading. High flows measured by floats.
 DRAINAGE AREA- 5.01 square miles.
 LOCATION- on the south bank of channel, 125 feet downstream from Sharp Avenue, about 3.6 miles south of San Fernando.
 REGULATION- flow from Lopez Creek is diverted to Hansen Dam at the mouth of Lopez Canyon.
 CHANNEL- trapezoidal, 10 feet wide at bottom and 7.5 feet deep with 1.5 to 1 side slopes.
 CONTROL- channel forms control.
 LENGTH OF RECORD- January 12, 1962 to date.

WATER YEAR 1989 - 90 (DISCHARGE IN SEC-FT.)

STATION NO. : F342-R

DRAINAGE AREA : 5.01 SQ. MI

		OCTOBER	NOVEMBER	DECEMBER	JANUARY	FEBRUARY	MARCH	APRIL	MAY	JUNE	JULY	AUGUST	SEPTEMBER
WATER YEAR 89-90	MEAN	0.2	0.4	0.0	2.1	2.7	0.2	0.1	0.5	0.0	0.0	0.2	0.0
	MAX.	5.3	11.9	0.1	31.9	46.9	3.4	2.6	13.4	0.1	0.1	6.3	0.1
	MIN.	0.0	0.0	0.0	0.0	0.0	0.0	0.0	0.0	0.0	0.0	0.0	0.0
TOTAL AF		13.7	24.4	0.4	126.0	147.0	10.5	5.8	29.2	0.2	0.4	13.1	0.4

LIMEKILN CREEK above Aliso Creek STATION NO. F350-R

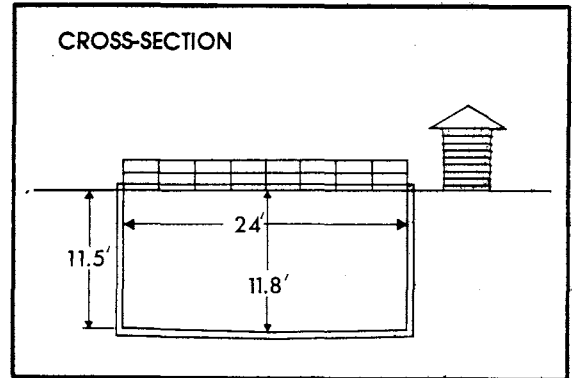
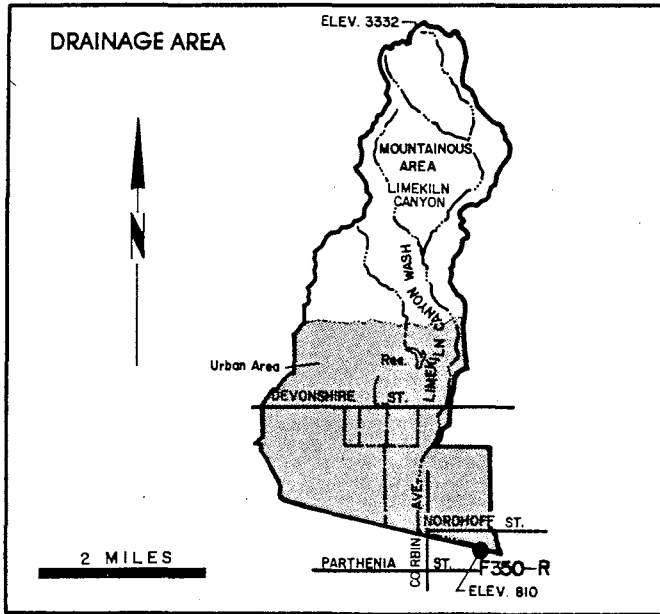
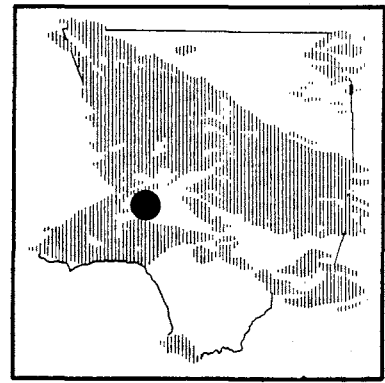

RECORDER- 15 minute punched tape.

METHOD OF MEASUREMENTS- low flows measured by wading. High flows measured from a steel footbridge 10 feet above the gage.

DRAINAGE AREA- 10.3 square miles.

LOCATION- on the south bank, 1,600 feet above Aliso Creek and one mile west of Northridge.

REGULATION- flow partly regulated by Limekiln Debris Basin.

CHANNEL- rectangular concrete.

LENGTH OF RECORD- see station summary.

WATER YEAR 1989 - 90 (DISCHARGE IN SEC-FT.)

STATION NO. : F350-R

DRAINAGE AREA : 10.30 sq. MI.

		OCTOBER	NOVEMBER	DECEMBER	JANUARY	FEBRUARY	MARCH	APRIL	MAY	JUNE	JULY	AUGUST	SEPTEMBER
WATER YEAR 89-90	MEAN	1.4	1.1	0.5	4.3	9.9	0.8	1.0	1.1	0.3	0.3	0.5	0.3
	MAX.	26.2	19.5	0.6	56.8	199.0	4.3	16.2	28.0	0.7	0.4	8.7	0.9
	MIN.	0.3	0.3	0.4	0.3	0.4	0.4	0.1	0.1	0.1	0.2	0.2	0.1
TOTAL AF		85.9	65.7	30.7	262.0	550.0	51.4	57.9	69.0	15.5	16.1	32.5	17.1

COYOTE CREEK

below Spring Street

STATION NO. F354-R

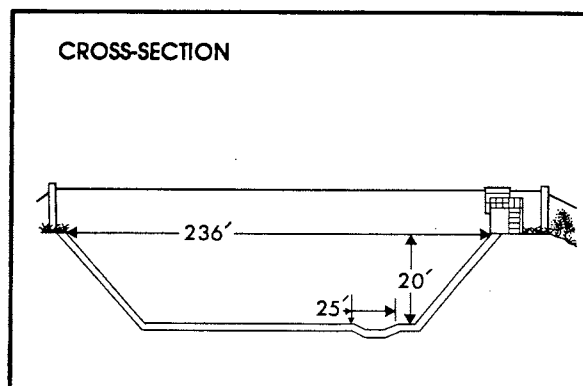
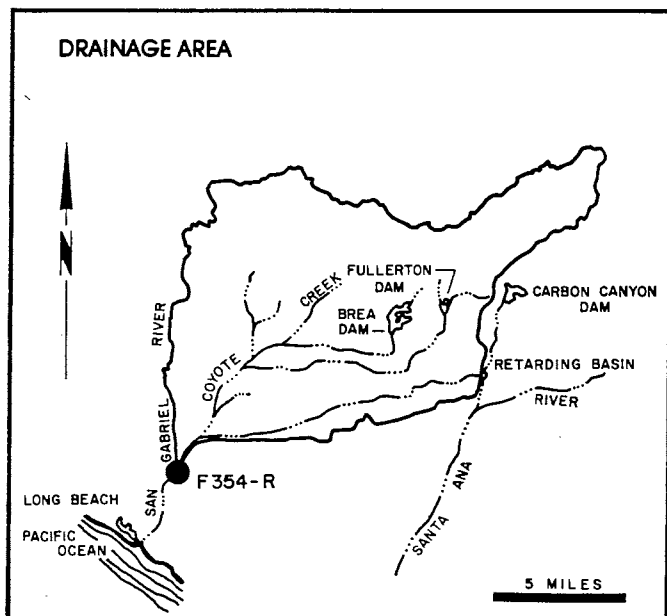
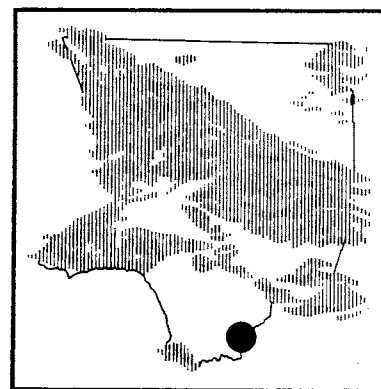

RECORDER- continuous water stage.

METHOD OF MEASUREMENTS- wading or from cable car.

DRAINAGE AREA- 185.0 square miles.

LOCATION- 241.0 feet below Spring Street, 7.5 miles northeast of Long Beach.

REGULATION- partially regulated by Fullerton Dam, Brea Dam, and Carbon Canyon Dam.

CHANNEL- concrete, trapezoidal in section.

CONTROL- channel forms control.

LENGTH OF RECORD - December 17, 1963 to date.

REMARKS - previous gaging stations for record correlation: Station F41 - S December 1, 1928 to January 14, 1930. Station F41 - R January 14, 1930 to October 30, 1936. Station F41B - R October 30, 1936 to February 17, 1937. Station F41C - R February 18, 1937 to February 8, 1956. Station F320 - R February 9, 1956 to July 2, 1965.

WATER YEAR 1989 - 90

(DISCHARGE IN SEC.-FT.)

STATION NO. : F354-R

DRAINAGE AREA : 185.00 SQ. MI.

		OCTOBER	NOVEMBER	DECEMBER	JANUARY	FEBRUARY	MARCH	APRIL	MAY	JUNE	JULY	AUGUST	SEPTEMBER
WATER YEAR 89-90	MEAN	21.4	6.2	6.0	67.4	58.1	8.0	13.4	16.3	5.7	6.6	8.2	7.6
	MAX.	287.0	19.6	15.1	507.0	648.0	11.6	85.7	260.0	9.4	11.2	18.9	12.0
	MIN.	4.7	3.7	3.7	2.3	4.4	5.3	5.1	3.9	3.7	4.5	6.0	4.5
TOTAL AF		1313.0	367.0	367.0	4145.0	3225.0	492.0	798.0	1000.0	342.0	408.0	502.0	452.0

BOUQUET CANYON CREEK

at Urbandale Avenue

STATION NO. F377-R

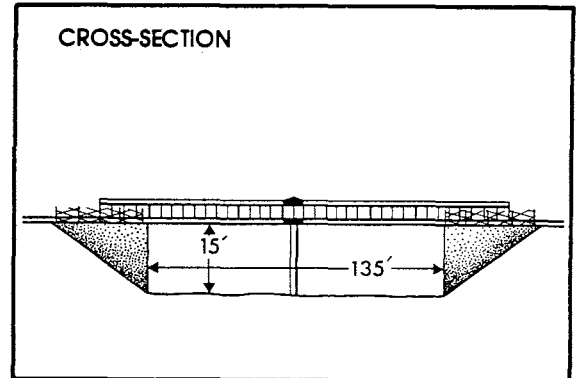
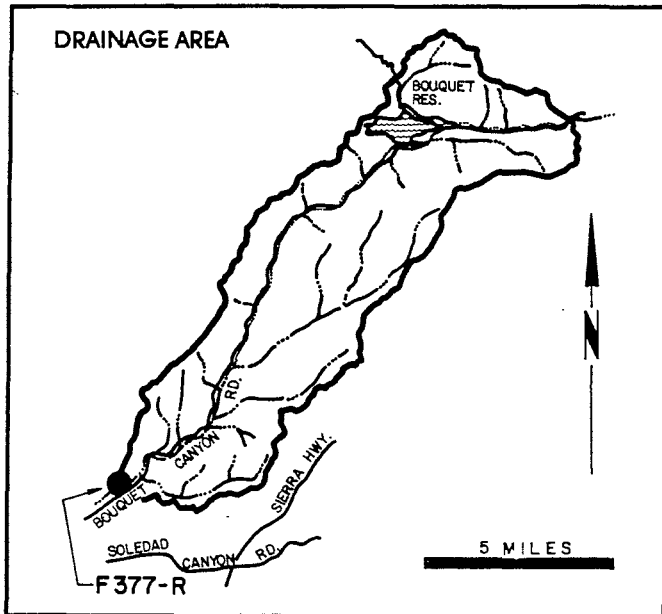
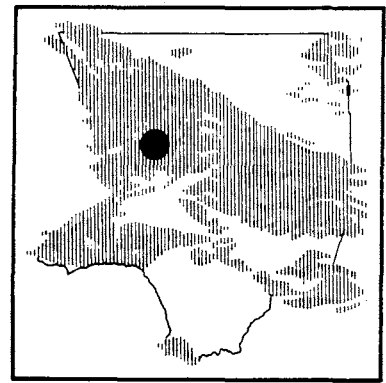

RECORDER- continuous water stage.
 METHOD OF MEASUREMENTS- wading or from bridge.
 DRAINAGE AREA- 51.9 square miles.
 LOCATION- Bouquet Canyon Creek at Urbandale Avenue, 3.5 miles northeast of Saugus.
 REGULATION- Bouquet Reservoir.
 CHANNEL- concrete sides with natural bottom, trapezoidal in section.
 CONTROL- concrete stabilizer.
 LENGTH OF RECORD- October 11, 1967 to date.

WATER YEAR 1989 - 90
 (DISCHARGE IN SEC-FT.)

STATION NO. : F377-R

DRAINAGE AREA : 51.90 SQ. MI.

		OCTOBER	NOVEMBER	DECEMBER	JANUARY	FEBRUARY	MARCH	APRIL	MAY	JUNE	JULY	AUGUST	SEPTEMBER
WATER YEAR 89-90	MEAN	0.0	0.0	0.0	0.0	0.0	0.1	0.4	0.0	0.0	0.0	0.0	0.0
	MAX.	0.2	0.3	0.0	0.7	0.0	0.9	2.8	0.0	0.0	0.0	0.0	0.0
	MIN.	0.0	0.0	0.0	0.0	0.0	0.0	0.0	0.0	0.0	0.0	0.0	0.0
TOTAL AF		0.8	0.6	0.0	1.4	0.0	3.9	23.2	0.0	0.0	0.0	0.0	0.0

DOMINGUEZ CHANNEL at Vermont Avenue STATION NO. F378-R

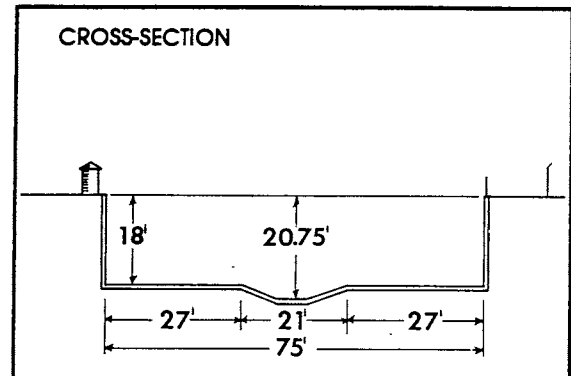
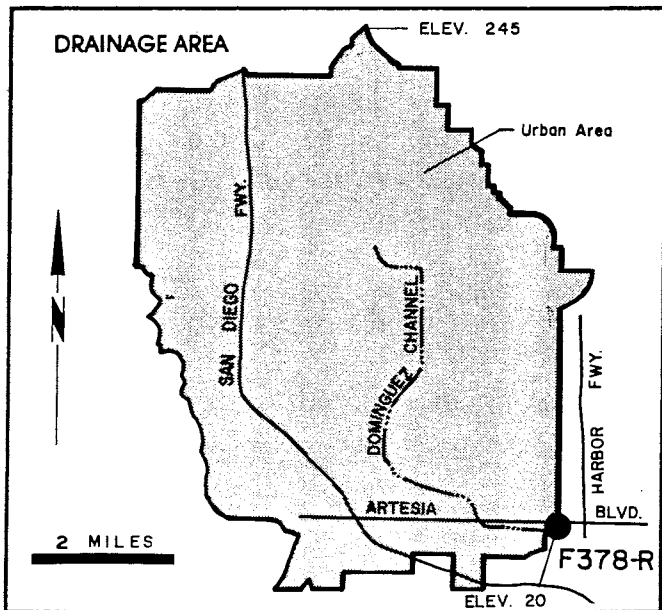
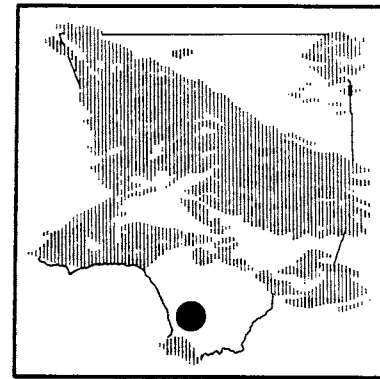

RECORDER- continuous water stage.

METHOD OF MEASUREMENTS-low flows measured by wading. High flows measured from Vermont Avenue bridge.

DRAINAGE AREA- 37.1 square miles.

LOCATION- on the south bank, 93 feet above Vermont Avenue, about one mile south of Gardena.

REGULATION- none

CHANNEL- rectangular concrete with trapezoidal low flow channel at center.

LENGTH OF RECORD- November 23, 1966 to date .

REMARKS- gage is affected by tides greater than 4.0 feet above mean lower low water.

WATER YEAR 1989 - 90 (DISCHARGE IN SEC.-FT.)

STATION NO. : F378-R

DRAINAGE AREA : 37.10 SQ. MI.

		OCTOBER	NOVEMBER	DECEMBER	JANUARY	FEBRUARY	MARCH	APRIL	MAY	JUNE	JULY	AUGUST	SEPTEMBER
WATER YEAR 89-90	MEAN	7.7	4.8	2.8	4.5	11.2	2.6	5.7	6.7	3.0	1.7	2.1	1.6
	MAX.	104.0	59.7	7.3	38.1	102.0	12.2	50.7	125.0	6.9	2.5	3.0	4.9
	MIN.	2.3	1.9	1.7	1.7	2.0	1.6	1.8	2.0	1.6	1.3	1.2	0.8
TOTAL AF		472.0	286.0	174.0	276.0	619.0	157.0	341.0	410.0	180.0	107.0	128.0	94.2

RESERVOIRS

RESERVOIRS

Following the damaging flood of 1914 and creation of the Los Angeles County Flood Control District in 1915, it initiated a program of flood control and water conservation including the construction of 14 dams. These dams were operated by the Department during the period covered by this report. In addition, five Corps of Engineers' dams and Morris Dam owned by The Metropolitan Water District were utilized to achieve flood control and water conservation. The Corps of Engineers' dams are: Hansen Dam on Tujunga Wash, Sepulveda Dam on the Los Angeles River, Santa Fe Dam on the San Gabriel River, Whittier Narrows Dam serving both the Rio Hondo and San Gabriel River, and San Antonio Dam on San Antonio Creek.

OPERATION

The reservoirs are operated to control flood waters during storm periods. Post storm releases are made, when feasible, in amounts which can be conserved in downstream spreading grounds and by channel percolation.

RECORDS

The storage and flow records at the 14 Department reservoirs are summarized on the Dam Operation Record Sheets. The sheets show:

1. Reservoir water surface elevations based on the spillway datum. Elevations are obtained from water stage recorder graphs or interpolation from staff gage readings and recorded as of midnight of each day. Only maximum and minimum water surface elevations for each year are shown.
2. Storage in acre-feet based on the most recent topographic surveys. Annual storage volumes are shown.
3. Inflow in cubic feet per second. This is usually calculated from storage change and known outflow. When outflow is not known, the inflow may be determined from gaging station records or interpolated between measurements. Only the maximum and minimum of the daily flow rates for the year and the instantaneous peak flow rate are shown.
4. Outflow in cubic feet per second. These values are determined from gaging station records, known valve openings and rating curves, or from storage change and known inflow. Only the maximum and minimum of the daily outflow rates for the year and the instantaneous peak outflow rate are shown.
5. Discrepancies between outflow and storage losses at certain dams are attributable to evaporation and/or percolation losses. Total monthly evaporation losses are determined from the measurements made on floating or land evaporation pans. In those cases where no allowances were made for evaporation, the amounts are necessarily included in the flow values. Accuracy of the flow records computed from storage records is dependent on the frequency with which storage data are revised to keep in step with the physical change in reservoirs.

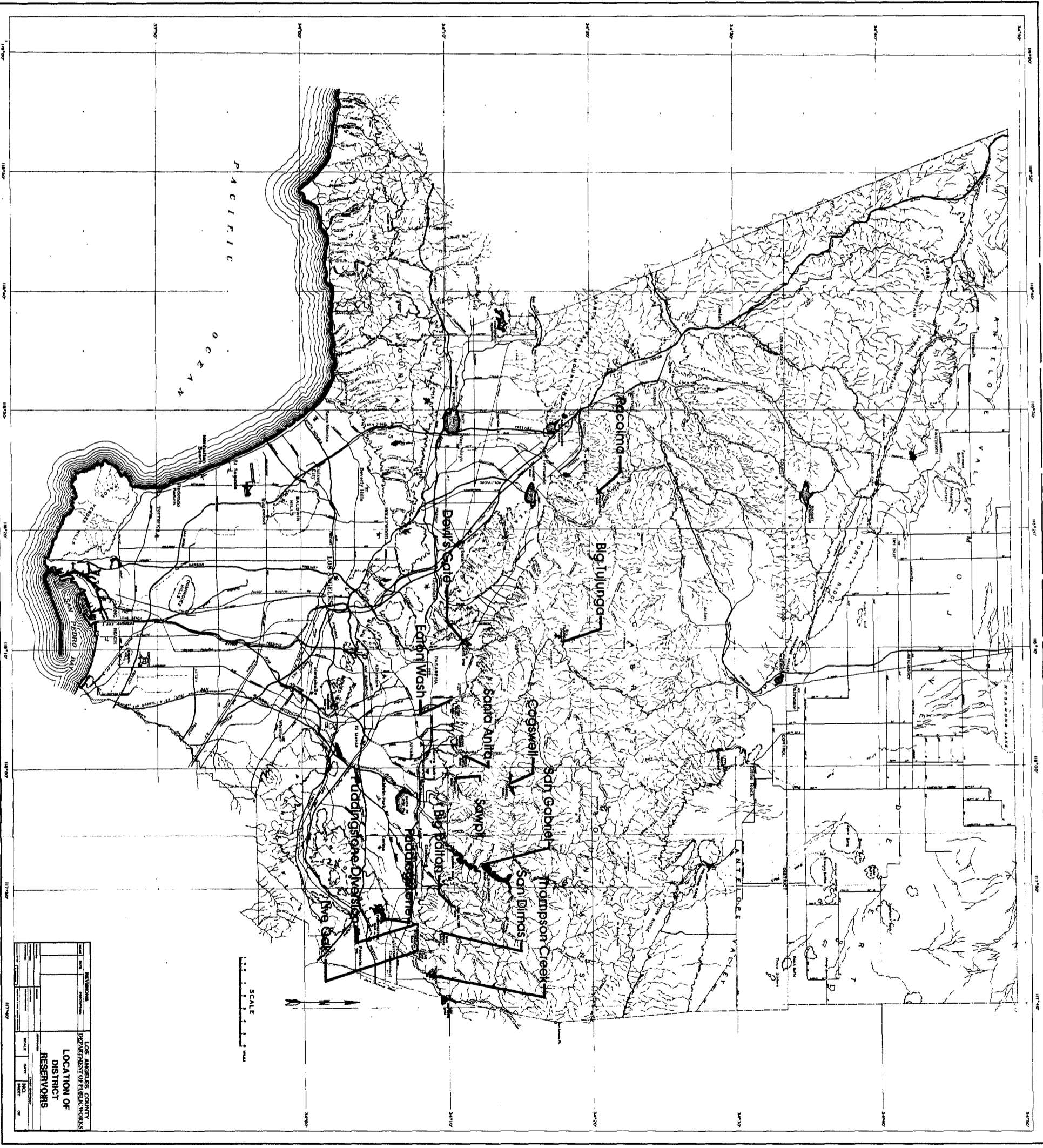

RESERVOIR	DATE	NO.	TEXT

LOS ANGELES COUNTY
DEPARTMENT OF PUBLIC WORKS
LOCATION OF
DISTRICT
RESERVOIRS

PACOIMA DAM AND RESERVOIR

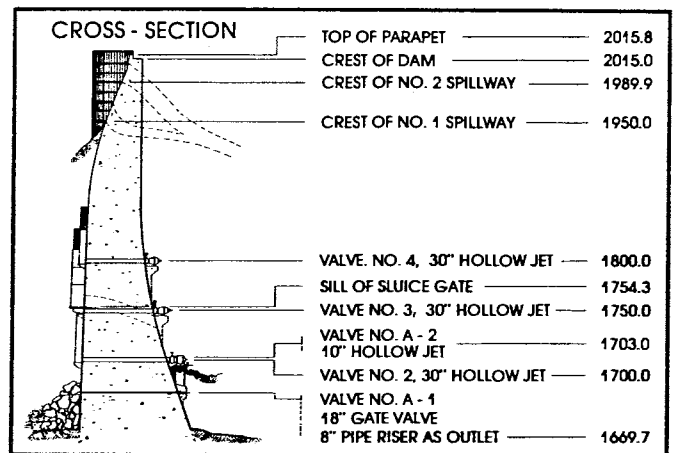
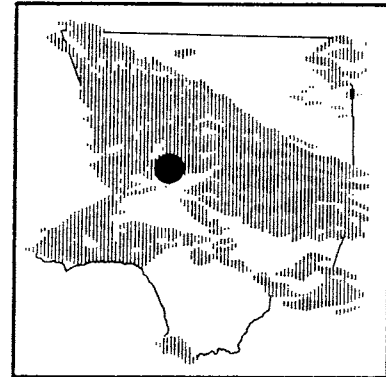
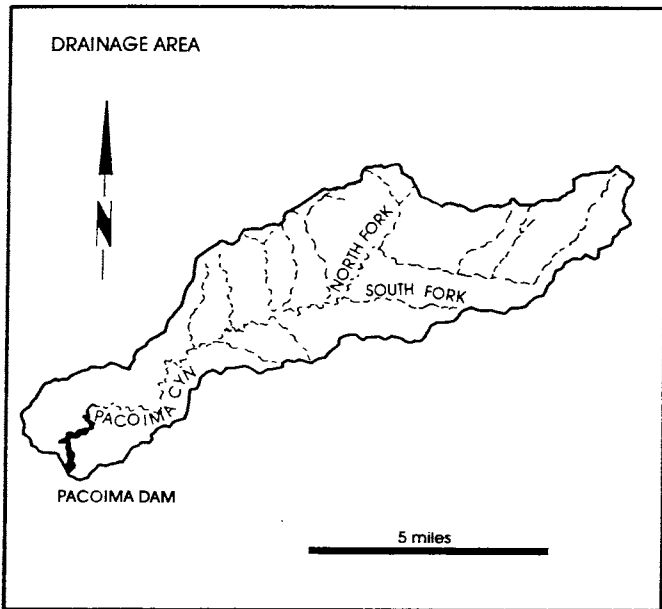

PURPOSE - Flood Control and Conservation.
DATE CONSTRUCTED - Started March 1925. Completed February 1929.
LOCATION - Pacoima Canyon, 4.0 miles northeast of San Fernando.
DRAINAGE AREA - 28.2 square miles.
CAPACITY - 3,929 acre - feet.
SPILLWAY ELEVATION - 1,950.0 feet.

DAM OPERATION RECORD SUMMARY

MAX. PEAK INFLOW	58.62 CFS from 1400 on 02-17-90 to 1500 on 02-17-90
MAX. PEAK OUTFLOW	291.00 CFS from 0745 on 05-21-90 to 0800 on 05-21-90
MAX. W.S. ELEVATION	1907.15 feet on 05-21-90 STORAGE 1791.62 ACRE-FEET
MIN. W.S. ELEVATION	1882.40 feet on varies STORAGE 1103.50 ACRE-FEET

PACOIMA DAM OPERATION RECORD SUMMARY

WATER YEAR 1989-90	OCTOBER	NOVEMBER	DECEMBER	JANUARY
TOTAL MONTHLY INFLOW (AF)	21.30	22.50	19.90	89.90
TOTAL MONTHLY OUTFLOW (AF)	4.20	0.00	0.00	60.10
MAX. MEAN DAILY INFLOW (CFS)	0.90	1.10	0.70	9.70
TOTAL MONTHLY LOSSES (AF)	18.20	21.50	19.10	14.70
MIN. MEAN DAILY INFLOW (CFS)	0.10	0.10	0.10	0.10
MONTHLY STORAGE CHANGE (AF)	-1.10	1.10	0.80	15.10

WATER YEAR 1989-90	FEBRUARY	MARCH	APRIL	MAY
TOTAL MONTHLY INFLOW (AF)	234.90	113.10	67.30	90.00
TOTAL MONTHLY OUTFLOW (AF)	0.00	0.00	0.00	752.90
MAX. MEAN DAILY INFLOW (CFS)	26.90	3.20	2.60	15.20
TOTAL MONTHLY LOSSES (AF)	11.40	14.10	13.30	18.30
MIN. MEAN DAILY INFLOW (CFS)	0.00	0.60	0.60	0.20
MONTHLY STORAGE CHANGE (AF)	223.50	99.10	54.00	-681.30

WATER YEAR 1989-90	JUNE	JULY	AUGUST	SEPTEMBER
TOTAL MONTHLY INFLOW (AF)	50.40	31.50	22.90	20.70
TOTAL MONTHLY OUTFLOW (AF)	0.00	0.00	0.00	0.00
MAX. MEAN DAILY INFLOW (CFS)	1.40	0.70	0.70	0.80
TOTAL MONTHLY LOSSES (AF)	18.40	19.80	16.40	18.30
MIN. MEAN DAILY INFLOW (CFS)	0.50	0.30	0.10	0.20
MONTHLY STORAGE CHANGE (AF)	32.00	11.70	6.50	2.30

BIG TUJUNGA DAM AND RESERVOIR

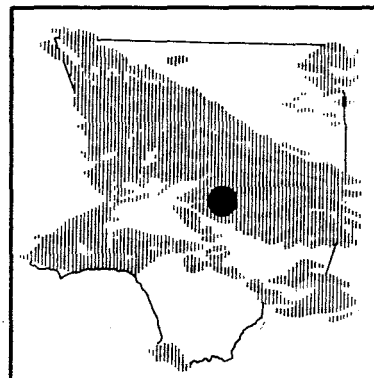
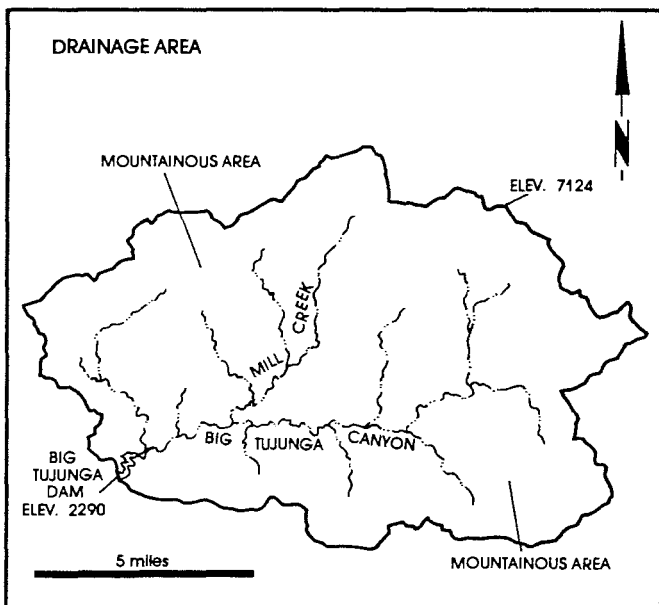

PURPOSE - Flood Control Conservation.
 DATE CONSTRUCTED - Started January 1930. Completed July 1931.
 LOCATION - Big Tujunga Canyon, 10.0 miles northeast of Sunland.
 DRAINAGE AREA - 82.3 square miles.
 CAPACITY - 6,027 acre - feet.
 SPILLWAY ELEVATION - 2,290.0 feet.

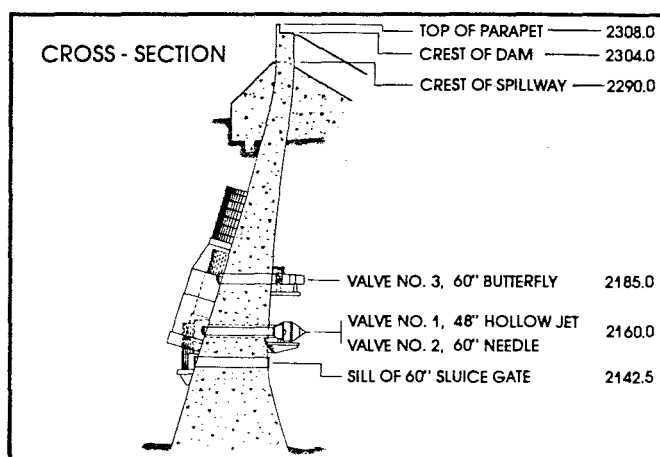

DAM OPERATION RECORD SUMMARY

MAX. PEAK INFLOW	62.36 CFS from 1500 on 02-17-90 to 1600 on 02-17-90
MAX. PEAK OUTFLOW	89.80 CFS from 0945 on 01-25-90 to 1000 on 01-25-90
MAX. W.S. ELEVATION	2214.74 feet on 01-15-90 STORAGE 1326.13 ACRE-FEET
MIN. W.S. ELEVATION	2205.00 feet on varies STORAGE 1053.00 ACRE-FEET

BIG TUJUNGA DAM OPERATION RECORD SUMMARY

WATER YEAR 1989-90	OCTOBER	NOVEMBER	DECEMBER	JANUARY
TOTAL MONTHLY INFLOW (AF)	54.00	131.40	137.40	357.00
TOTAL MONTHLY OUTFLOW (AF)	32.30	68.60	49.90	352.30
MAX. MEAN DAILY INFLOW (CFS)	3.40	3.60	3.40	26.10
TOTAL MONTHLY LOSSES (AF)	14.70	14.90	14.20	11.60
MIN. MEAN DAILY INFLOW (CFS)	0.00	0.30	0.30	1.60
MONTHLY STORAGE CHANGE (AF)	7.10	47.90	73.30	-6.90

WATER YEAR 1989-90	FEBRUARY	MARCH	APRIL	MAY
TOTAL MONTHLY INFLOW (AF)	440.10	270.30	216.20	129.20
TOTAL MONTHLY OUTFLOW (AF)	432.60	228.40	241.50	35.40
MAX. MEAN DAILY INFLOW (CFS)	40.90	6.80	5.70	5.40
TOTAL MONTHLY LOSSES (AF)	9.10	12.50	13.40	17.70
MIN. MEAN DAILY INFLOW (CFS)	0.00	0.40	1.90	0.70
MONTHLY STORAGE CHANGE (AF)	-1.60	29.40	-38.80	76.00

WATER YEAR 1989-90	JUNE	JULY	AUGUST	SEPTEMBER
TOTAL MONTHLY INFLOW (AF)	61.30	23.30	10.70	11.80
TOTAL MONTHLY OUTFLOW (AF)	27.60	0.00	0.00	0.00
MAX. MEAN DAILY INFLOW (CFS)	5.40	0.60	0.40	0.40
TOTAL MONTHLY LOSSES (AF)	21.80	30.70	25.20	25.50
MIN. MEAN DAILY INFLOW (CFS)	0.00	0.00	0.00	0.00
MONTHLY STORAGE CHANGE (AF)	12.00	-7.40	-14.60	-13.70

DEVIL'S GATE DAM AND RESERVOIR

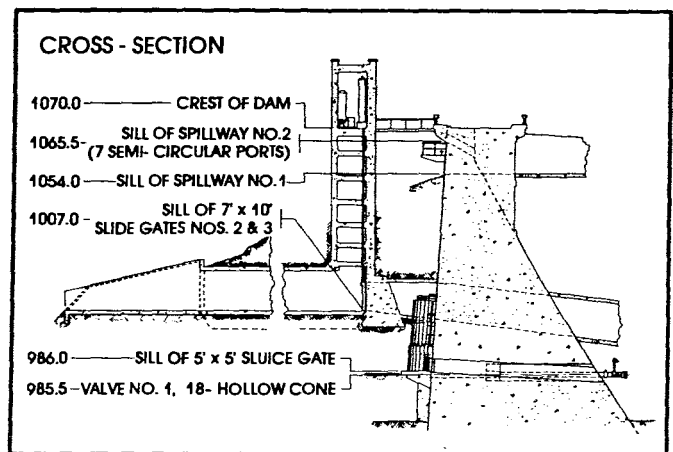
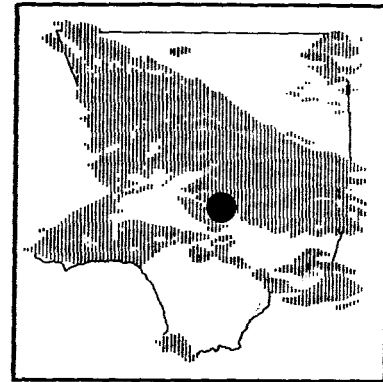
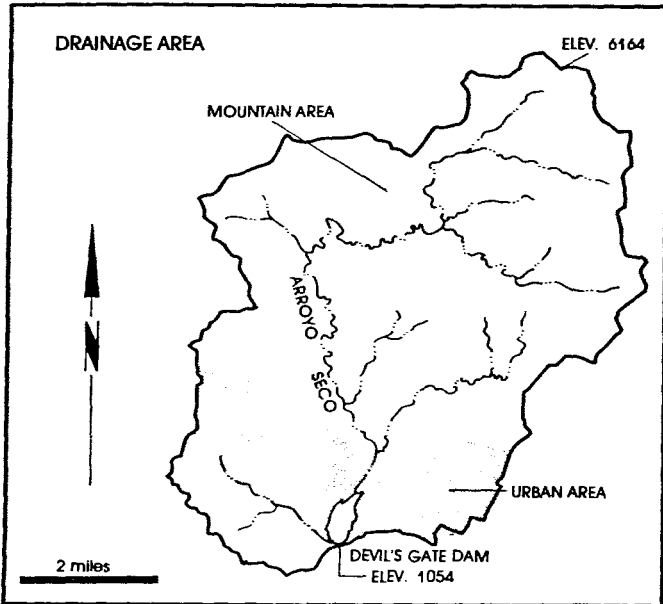

PURPOSE - Flood Control and Conservation.
 DATE CONSTRUCTED - Started May 1919. Completed June 1920.
 LOCATION - On Arroyo Seco, northwest of Pasadena.
 DRAINAGE AREA - 31.9 square miles.
 CAPACITY - 1,928 acre - feet.
 SPILLWAY ELEVATION - 1,054.0 feet.

DAM OPERATION RECORD SUMMARY *

MAX. PEAK INFLOW	88.31	CPS	from	1400	on	02-17-90	to	1500	on	02-17-90
MAX. PEAK OUTFLOW	11.80	CPS	from	1400	on	02-17-90	to	1415	on	02-17-90
MAX. W.S. ELEVATION	996.22	feet	on	02-17-90	STORAGE	0.80	ACRE-FEET			
MIN. W.S. ELEVATION	993.20	feet	on	varies	STORAGE	0.00	ACRE-FEET			

DEVIL'S GATE DAM OPERATION RECORD SUMMARY *

WATER YEAR 1989-90	OCTOBER	NOVEMBER	DECEMBER	JANUARY
TOTAL MONTHLY INFLOW (AF)	5.40	4.20	0.00	46.60
TOTAL MONTHLY OUTFLOW (AF)	5.40	4.20	0.00	46.60
MAX. MEAN DAILY INFLOW (CFS)	2.10	2.10	0.00	3.90
TOTAL MONTHLY LOSSES (AF)	0.00	0.00	0.00	0.00
MIN. MEAN DAILY INFLOW (CFS)	0.00	0.00	0.00	0.20
MONTHLY STORAGE CHANGE (AF)	0.00	0.00	0.00	0.00

WATER YEAR 1988-89	FEBRUARY	MARCH	APRIL	MAY
TOTAL MONTHLY INFLOW (AF)	56.30	12.90	11.90	4.20
TOTAL MONTHLY OUTFLOW (AF)	56.30	12.90	11.90	4.20
MAX. MEAN DAILY INFLOW (CFS)	11.80	0.40	0.20	2.10
TOTAL MONTHLY LOSSES (AF)	0.00	0.00	0.00	0.00
MIN. MEAN DAILY INFLOW (CFS)	0.10	0.20	0.20	0.00
MONTHLY STORAGE CHANGE (AF)	0.00	0.00	0.00	0.00

WATER YEAR 1988-89	JUNE	JULY	AUGUST	SEPTEMBER
TOTAL MONTHLY INFLOW (AF)	0.00	0.00	0.00	0.00
TOTAL MONTHLY OUTFLOW (AF)	0.00	0.00	0.00	0.00
MAX. MEAN DAILY INFLOW (CFS)	0.00	0.00	0.00	0.00
TOTAL MONTHLY LOSSES (AF)	0.00	0.00	0.00	0.00
MIN. MEAN DAILY INFLOW (CFS)	0.00	0.00	0.00	0.00
MONTHLY STORAGE CHANGE (AF)	0.00	0.00	0.00	0.00

* = VALUES ESTIMATED DUE TO INCOMPLETE RECORDS

EATON WASH DAM AND RESERVOIR

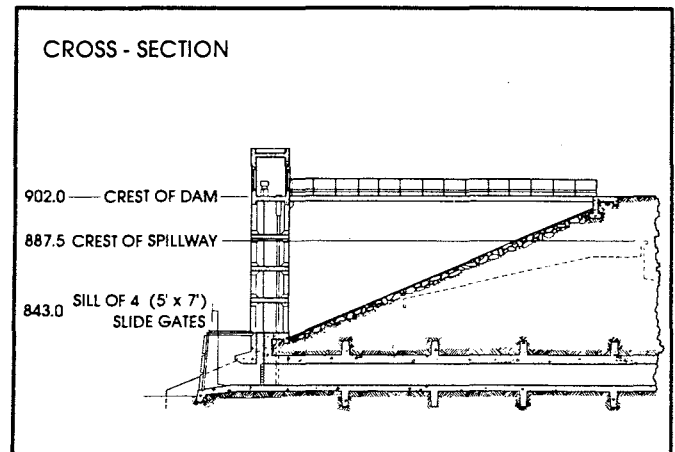
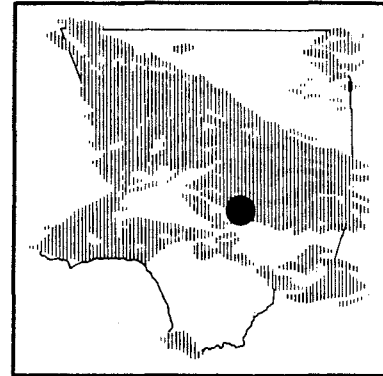
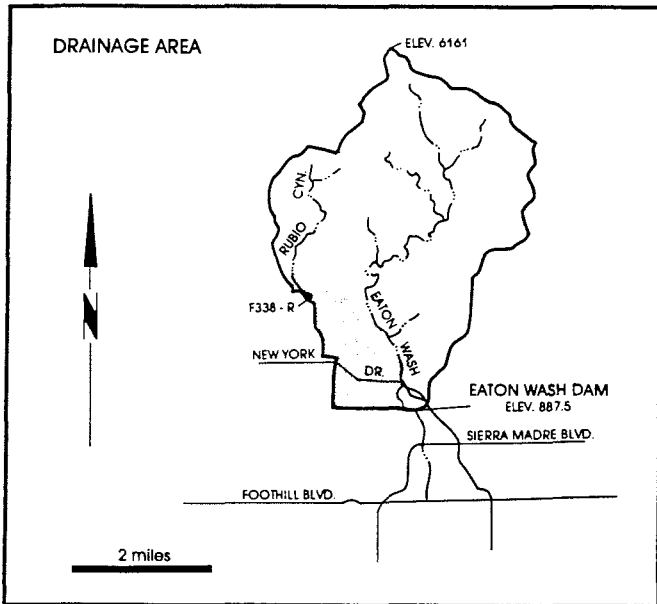

PURPOSE - Debris Storage and Conservation.
 DATE CONSTRUCTED - Started January 1936. Completed February 1937.
 LOCATION - Eaton Wash, northeast of Pasadena.
 DRAINAGE AREA - 12.4 square miles.
 CAPACITY - 879 acre - feet.
 SPILLWAY ELEVATION - 887.5 feet.

DAM OPERATION RECORD SUMMARY

MAX. PEAK INFLOW	63.45 CFS from 1800 on 02-17-90 to 1900 on 02-17-90
MAX. PEAK OUTFLOW	22.50 CFS from 0900 on 02-21-90 to 0915 on 02-21-90
MAX. W.S. ELEVATION	861.85 feet on 02-18-90 STORAGE 93.11 ACRE-FEET
MIN. W.S. ELEVATION	846.00 feet on varies STORAGE 0.00 ACRE-FEET

EATON WASH DAM OPERATION RECORD SUMMARY

WATER YEAR 1989-90	OCTOBER	NOVEMBER	DECEMBER	JANUARY
TOTAL MONTHLY INFLOW (AF)	0.00	0.00	0.00	45.50
TOTAL MONTHLY OUTFLOW (AF)	0.00	0.00	0.00	0.00
MAX. MEAN DAILY INFLOW (CFS)	0.00	0.00	0.00	7.50
TOTAL MONTHLY LOSSES (AF)	0.00	0.00	0.00	17.10
MIN. MEAN DAILY INFLOW (CFS)	0.00	0.00	0.00	0.00
MONTHLY STORAGE CHANGE (AF)	0.00	0.00	0.00	28.40

WATER YEAR 1989-90	FEBRUARY	MARCH	APRIL	MAY
TOTAL MONTHLY INFLOW (AF)	100.80	0.90	48.60	35.40
TOTAL MONTHLY OUTFLOW (AF)	58.50	19.50	26.80	26.10
MAX. MEAN DAILY INFLOW (CFS)	39.80	0.10	10.10	5.20
TOTAL MONTHLY LOSSES (AF)	26.80	25.90	9.60	2.80
MIN. MEAN DAILY INFLOW (CFS)	0.00	0.00	0.00	0.00
MONTHLY STORAGE CHANGE (AF)	15.40	-44.50	12.10	6.50

WATER YEAR 1989-90	JUNE	JULY	AUGUST	SEPTEMBER
TOTAL MONTHLY INFLOW (AF)	1.10	0.60	0.00	0.00
TOTAL MONTHLY OUTFLOW (AF)	0.00	0.00	0.00	0.00
MAX. MEAN DAILY INFLOW (CFS)	0.10	0.10	0.00	0.00
TOTAL MONTHLY LOSSES (AF)	14.30	2.80	0.00	0.00
MIN. MEAN DAILY INFLOW (CFS)	0.00	0.00	0.00	0.00
MONTHLY STORAGE CHANGE (AF)	-15.50	-2.20	0.00	0.00

SANTA ANITA DAM AND RESERVOIR

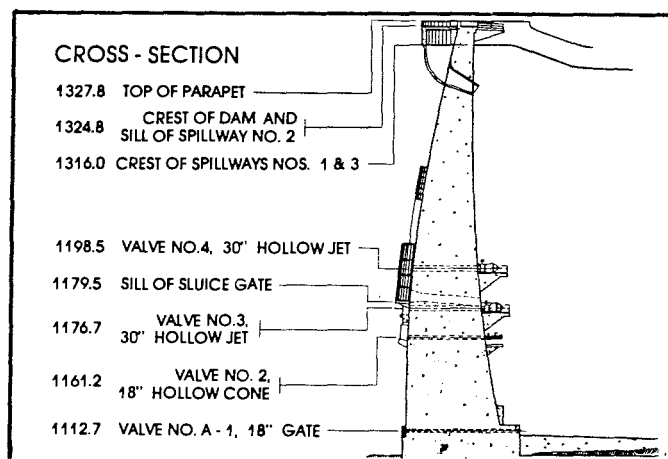
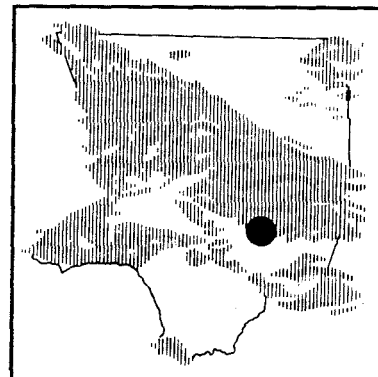
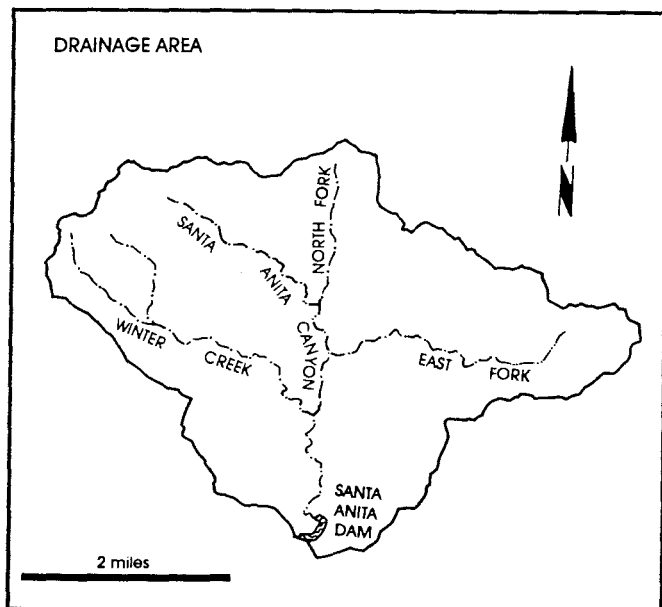

PURPOSE - Flood Control and Conservation.
 DATE CONSTRUCTED - Started October 1924. Completed March 1927.
 LOCATION - 2.5 miles north of Arcadia
 DRAINAGE AREA - 10.8 square miles.
 CAPACITY - 836 acre - feet.
 SPILLWAY ELEVATION - 1,316.0 feet.

DAM OPERATION RECORD SUMMARY

MAX. PEAK INFLOW	117.24 CFS from 1500 on 02-17-90 to 1600 on 02-17-90
MAX. PEAK OUTFLOW	30.60 CFS from 1925 on 02-17-90 to 1940 on 02-17-90
MAX. W.S. ELEVATION	1264.44 feet on 02-28-90 STORAGE 297.28 ACRE-FEET
MIN. W.S. ELEVATION	1241.17 feet on 05-17-90 STORAGE 156.34 ACRE-FEET

SANTA ANITA DAM OPERATION RECORD SUMMARY

WATER YEAR 1989-90	OCTOBER	NOVEMBER	DECEMBER	JANUARY
TOTAL MONTHLY INFLOW (AF)	17.20	37.30	34.10	96.70
TOTAL MONTHLY OUTFLOW (AF)	0.00	73.20	0.00	94.20
MAX. MEAN DAILY INFLOW (CFS)	0.50	1.70	0.70	10.80
TOTAL MONTHLY LOSSES (AF)	2.20	2.30	2.00	1.60
MIN. MEAN DAILY INFLOW (CFS)	0.00	0.30	0.30	0.30
MONTHLY STORAGE CHANGE (AF)	15.00	-38.20	32.10	0.90

WATER YEAR 1989-90	FEBRUARY	MARCH	APRIL	MAY
TOTAL MONTHLY INFLOW (AF)	207.50	107.00	87.50	77.20
TOTAL MONTHLY OUTFLOW (AF)	147.20	110.70	121.00	114.40
MAX. MEAN DAILY INFLOW (CFS)	29.70	6.60	4.90	4.60
TOTAL MONTHLY LOSSES (AF)	1.50	1.50	1.20	1.90
MIN. MEAN DAILY INFLOW (CFS)	0.80	0.20	0.90	0.50
MONTHLY STORAGE CHANGE (AF)	58.80	-5.30	-34.70	-39.10

WATER YEAR 1989-90	JUNE	JULY	AUGUST	SEPTEMBER
TOTAL MONTHLY INFLOW (AF)	37.80	22.00	7.10	5.30
TOTAL MONTHLY OUTFLOW (AF)	0.00	79.30	0.00	0.00
MAX. MEAN DAILY INFLOW (CFS)	1.90	2.50	0.20	0.10
TOTAL MONTHLY LOSSES (AF)	2.60	3.40	2.50	2.70
MIN. MEAN DAILY INFLOW (CFS)	0.00	0.10	0.00	0.00
MONTHLY STORAGE CHANGE (AF)	35.20	-60.80	4.60	2.60

SAWPIT DAM AND RESERVOIR

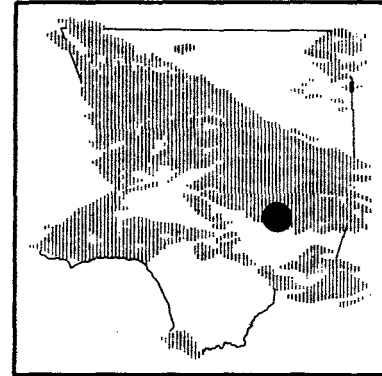
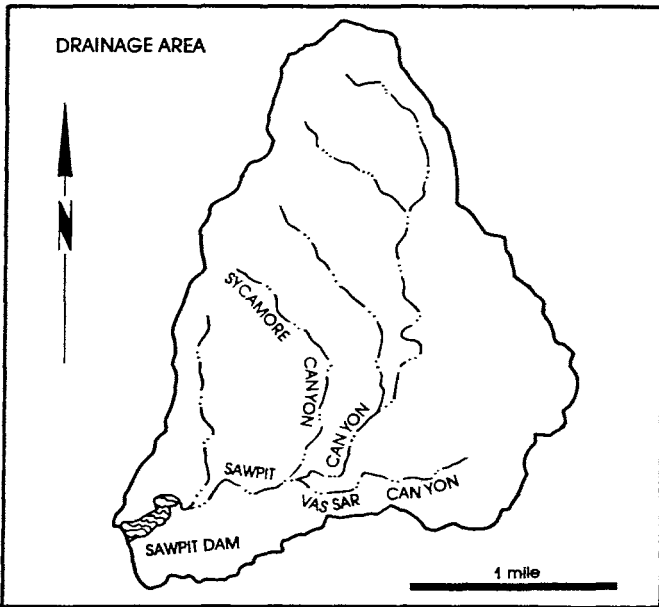

PURPOSE - Flood Control and Conservation.
 DATE CONSTRUCTED - Started March 1926. Completed June 1927.
 LOCATION - 2.0 miles north of Monrovia.
 DRAINAGE AREA - 3.2 square miles.
 CAPACITY - 391 acre - feet.
 SPILLWAY ELEVATION - 1,360.0 feet.

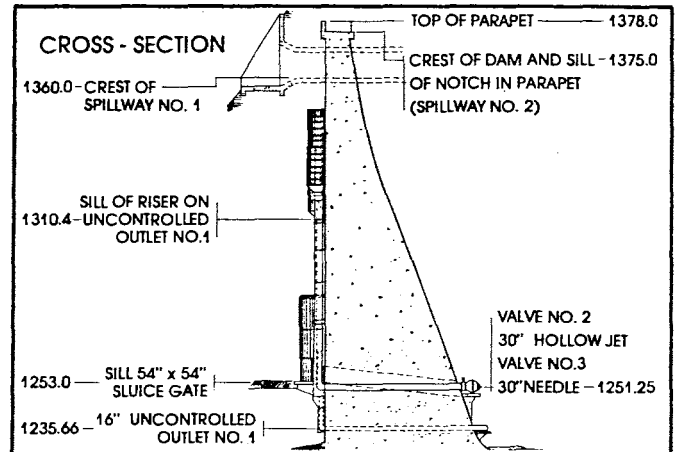

DAM OPERATION RECORD SUMMARY

MAX. PEAK INFLOW	15.64 CFS from 1700 on 02-17-90 to 1800 on 02-17-90
MAX. PEAK OUTFLOW	77.90 CFS from 1315 on 10-26-89 to 1330 on 10-26-89
MAX. W.S. ELEVATION	1310.68 feet on 02-17-90 STORAGE 97.28 ACRE-FEET
MIN. W.S. ELEVATION	1309.30 feet on varies STORAGE 92.40 ACRE-FEET

SAWPIT DAM OPERATION RECORD SUMMARY

WATER YEAR 1989-90	OCTOBER	NOVEMBER	DECEMBER	JANUARY
TOTAL MONTHLY INFLOW (AF)	39.30	36.50	23.90	63.90
TOTAL MONTHLY OUTFLOW (AF)	42.60	33.70	24.00	64.10
MAX. MEAN DAILY INFLOW (CFS)	0.90	1.30	1.20	2.40
TOTAL MONTHLY LOSSES (AF)	0.00	0.00	0.00	0.00
MIN. MEAN DAILY INFLOW (CFS)	0.00	0.20	0.20	0.40
MONTHLY STORAGE CHANGE (AF)	-3.30	2.80	-0.10	-0.20

WATER YEAR 1989-90	FEBRUARY	MARCH	APRIL	MAY
TOTAL MONTHLY INFLOW (AF)	93.90	61.50	59.50	99.90
TOTAL MONTHLY OUTFLOW (AF)	85.30	61.50	59.50	100.00
MAX. MEAN DAILY INFLOW (CFS)	6.30	1.00	1.00	2.90
TOTAL MONTHLY LOSSES (AF)	8.40	0.00	0.00	0.00
MIN. MEAN DAILY INFLOW (CFS)	1.10	1.00	1.00	1.10
MONTHLY STORAGE CHANGE (AF)	0.20	0.00	0.00	0.00

WATER YEAR 1989-90	JUNE	JULY	AUGUST	SEPTEMBER
TOTAL MONTHLY INFLOW (AF)	38.90	7.40	8.90	0.60
TOTAL MONTHLY OUTFLOW (AF)	38.90	7.40	8.90	0.60
MAX. MEAN DAILY INFLOW (CFS)	1.40	0.30	0.30	0.10
TOTAL MONTHLY LOSSES (AF)	0.00	0.00	0.00	0.00
MIN. MEAN DAILY INFLOW (CFS)	0.10	0.00	0.10	0.00
MONTHLY STORAGE CHANGE (AF)	0.00	0.00	0.00	0.00

COGSWELL DAM AND RESERVOIR

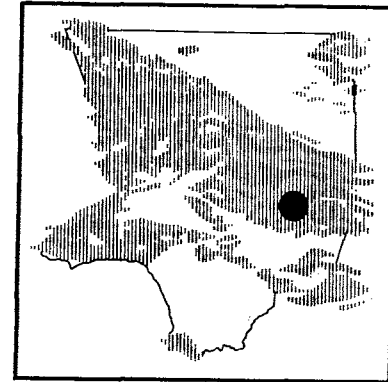
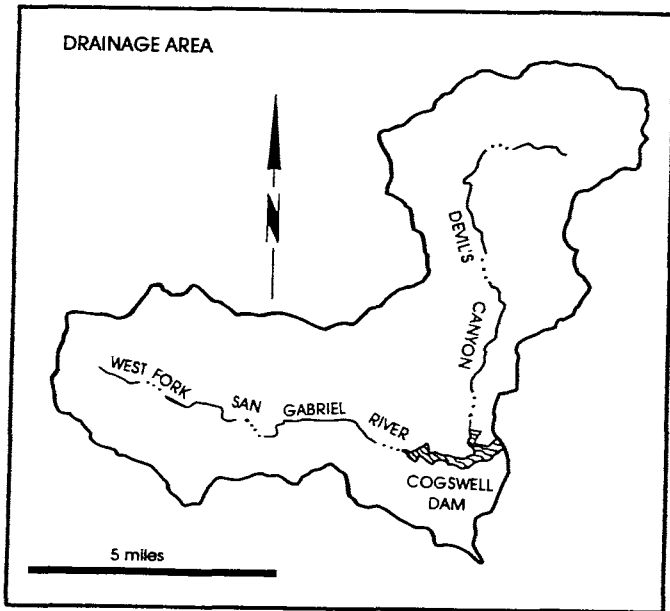

PURPOSE - Flood Control, Conservation, and Recreation.
 DATE CONSTRUCTED - Started March 1932. Completed April 1934.
 LOCATION - 22.0 miles north of Azusa.
 DRAINAGE AREA - 39.2 square miles.
 CAPACITY - 9,339 acre - feet.
 SPILLWAY ELEVATION - 2,385.0 feet.

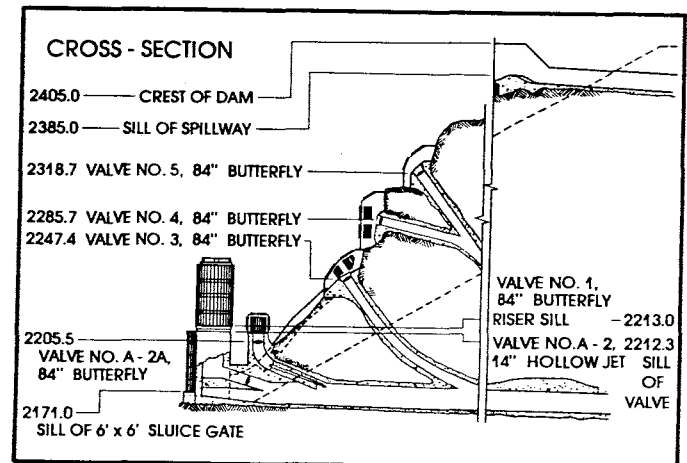

DAM OPERATION RECORD SUMMARY

MAX. PEAK INFLOW	98.74 CFS from 0400 on 02-18-90 to 0500 on 02-18-90
MAX. PEAK OUTFLOW	137.00 CFS from 0900 on 11-14-89 to 0930 on 11-14-89
MAX. W.S. ELEVATION	2295.62 feet on 04-26-90 STORAGE 1262.68 ACRE-FEET
MIN. W.S. ELEVATION	2257.67 feet on 01-12-90 STORAGE 388.39 ACRE-FEET

COGSWELL DAM OPERATION RECORD SUMMARY

WATER YEAR 1989-90	OCTOBER	NOVEMBER	DECEMBER	JANUARY
TOTAL MONTHLY INFLOW (AF)	19.10	15.00	13.20	184.10
TOTAL MONTHLY OUTFLOW (AF)	129.10	120.20	95.00	105.30
MAX. MEAN DAILY INFLOW (CFS)	1.50	0.90	0.50	17.30
TOTAL MONTHLY LOSSES (AF)	7.20	4.10	2.80	2.10
MIN. MEAN DAILY INFLOW (CFS)	0.00	0.00	0.00	0.20
MONTHLY STORAGE CHANGE (AF)	-117.30	-109.30	-84.20	76.60

WATER YEAR 1989-90	FEBRUARY	MARCH	APRIL	MAY
TOTAL MONTHLY INFLOW (AF)	672.00	346.80	202.60	127.40
TOTAL MONTHLY OUTFLOW (AF)	127.70	135.50	172.40	165.80
MAX. MEAN DAILY INFLOW (CFS)	61.20	10.70	7.00	5.00
TOTAL MONTHLY LOSSES (AF)	2.40	6.70	8.20	13.90
MIN. MEAN DAILY INFLOW (CFS)	1.80	3.50	2.30	1.20
MONTHLY STORAGE CHANGE (AF)	541.90	204.60	22.00	-52.30

WATER YEAR 1989-90	JUNE	JULY	AUGUST	SEPTEMBER
TOTAL MONTHLY INFLOW (AF)	99.20	138.30	53.10	32.10
TOTAL MONTHLY OUTFLOW (AF)	178.30	240.40	165.00	140.40
MAX. MEAN DAILY INFLOW (CFS)	2.70	3.00	1.30	1.00
TOTAL MONTHLY LOSSES (AF)	18.00	21.80	16.80	12.40
MIN. MEAN DAILY INFLOW (CFS)	1.00	1.20	0.40	0.10
MONTHLY STORAGE CHANGE (AF)	-97.10	-123.90	-128.80	-120.70

SAN GABRIEL DAM AND RESERVOIR

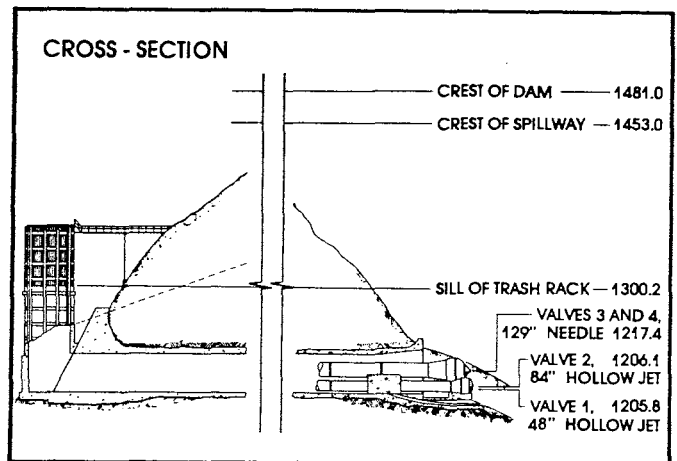
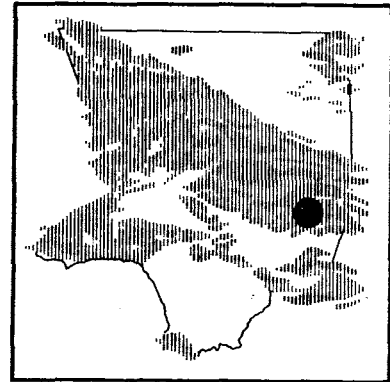
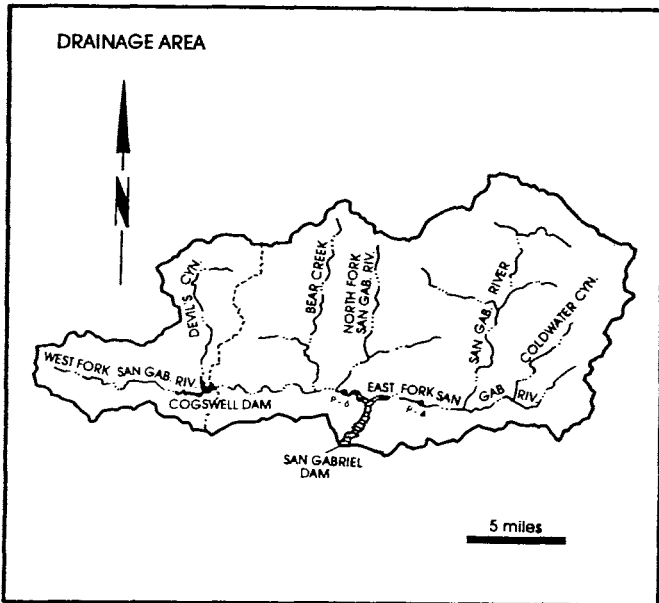

PURPOSE - Flood Control and Conservation.
DATE CONSTRUCTED - Started December 1932. Completed July 1939.
LOCATION - San Gabriel Canyon, 7.5 miles north of Azusa.
DRAINAGE AREA - 163.5 square miles (uncontrolled)
 39.2 square miles (controlled)
 Total 202.7 square miles
 (includes Cogswell drainage)
CAPACITY - 41,549 acre - feet.
SPILLWAY ELEVATION - 1,453 feet.

DAM OPERATION RECORD SUMMARY

MAX. PEAK INFLOW	387.55 CFS	from	0600	on	02-18-90	to	0700	on	02-18-90
MAX. PEAK OUTFLOW	66.70 CFS	from	0415	on	03-02-90	to	0430	on	03-02-90
MAX. W.S. ELEVATION	1360.40 feet	on	05-03-90	STORAGE	9097.00	ACRE-FEET			
MIN. W.S. ELEVATION	1325.70 feet	on	10-12-90	STORAGE	2456.00	ACRE-FEET			

SAN GABRIEL DAM OPERATION RECORD SUMMARY

WATER YEAR 1989-90	OCTOBER	NOVEMBER	DECEMBER	JANUARY
TOTAL MONTHLY INFLOW (AF)	724.10	771.50	885.00	2451.40
TOTAL MONTHLY OUTFLOW (AF)	476.20	820.80	842.80	993.10
MAX. MEAN DAILY INFLOW (CFS)	16.70	16.90	16.80	189.80
TOTAL MONTHLY LOSSES (AF)	61.00	53.90	43.40	38.00
MIN. MEAN DAILY INFLOW (CFS)	7.90	10.50	12.50	14.70
MONTHLY STORAGE CHANGE (AF)	186.90	-103.10	-1.20	1420.20

WATER YEAR 1989-90	FEBRUARY	MARCH	APRIL	MAY
TOTAL MONTHLY INFLOW (AF)	3251.10	3471.00	2806.30	2053.90
TOTAL MONTHLY OUTFLOW (AF)	818.40	1848.40	1520.30	2099.10
MAX. MEAN DAILY INFLOW (CFS)	248.10	69.80	62.80	52.10
TOTAL MONTHLY LOSSES (AF)	52.50	79.80	90.10	135.10
MIN. MEAN DAILY INFLOW (CFS)	24.20	46.20	36.50	25.40
MONTHLY STORAGE CHANGE (AF)	2380.20	1542.80	1195.80	-180.30

WATER YEAR 1989-90	JUNE	JULY	AUGUST	SEPTEMBER
TOTAL MONTHLY INFLOW (AF)	1194.80	570.50	436.70	362.20
TOTAL MONTHLY OUTFLOW (AF)	2035.00	2104.50	2102.90	1346.60
MAX. MEAN DAILY INFLOW (CFS)	30.80	15.20	10.50	9.50
TOTAL MONTHLY LOSSES (AF)	177.60	187.50	143.50	113.00
MIN. MEAN DAILY INFLOW (CFS)	8.00	5.80	3.60	2.30
MONTHLY STORAGE CHANGE (AF)	-1017.90	-1721.50	-1809.70	-1097.40

BIG DALTON DAM AND RESERVOIR

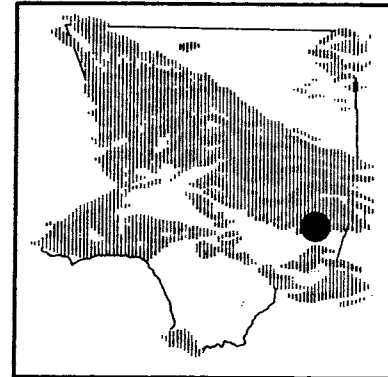
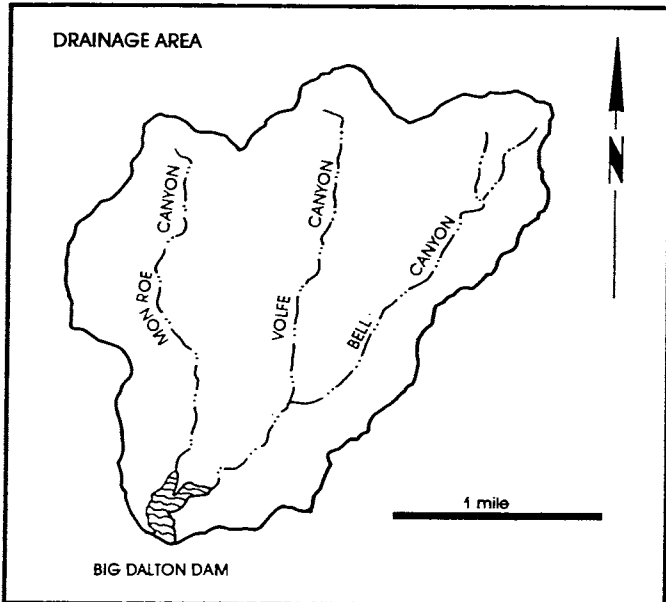

PURPOSE - Flood Control and Conservation.
 DATE CONSTRUCTED - Started December 1927. Completed August 1929.
 LOCATION - Big Dalton Canyon, 4.0 miles northeast of Glendora.
 DRAINAGE AREA - 4.5 square miles.
 CAPACITY - 963 acre - feet.
 SPILLWAY ELEVATION - 1,706.0 feet.

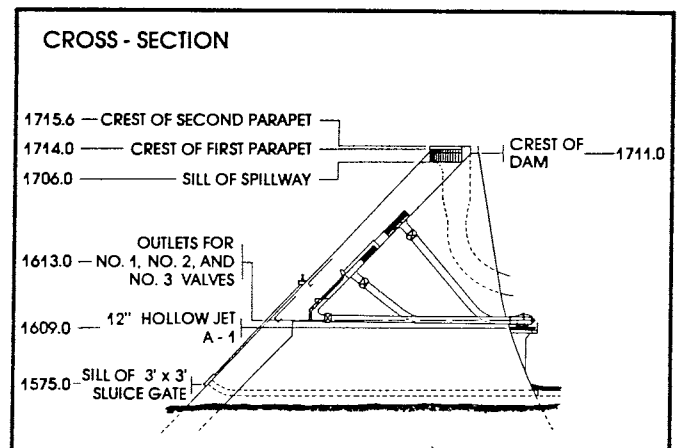

DAM OPERATION RECORD SUMMARY

MAX. PEAK INFLOW	7.80 CFS from 1600 on 02-17-90 to 1700 on 02-17-90
MAX. PEAK OUTFLOW	4.88 CFS from 0915 on 01-25-90 to 0930 on 01-25-90
MAX. W.S. ELEVATION	1639.60 feet on 05-14-90 STORAGE 83.90 ACRE-FEET
MIN. W.S. ELEVATION	1632.80 feet on 01-27-90 STORAGE 60.60 ACRE-FEET

BIG DALTON DAM OPERATION RECORD SUMMARY

WATER YEAR 1989-90	OCTOBER	NOVEMBER	DECEMBER	JANUARY
TOTAL MONTHLY INFLOW (AF)	2.00	1.30	1.20	6.70
TOTAL MONTHLY OUTFLOW (AF)	0.00	0.00	0.00	21.70
MAX. MEAN DAILY INFLOW (CFS)	0.20	0.10	0.10	0.80
TOTAL MONTHLY LOSSES (AF)	1.20	1.00	0.80	0.60
MIN. MEAN DAILY INFLOW (CFS)	0.00	0.00	0.00	0.00
MONTHLY STORAGE CHANGE (AF)	0.70	0.30	0.40	-15.60

WATER YEAR 1989-90	FEBRUARY	MARCH	APRIL	MAY
TOTAL MONTHLY INFLOW (AF)	11.70	20.90	16.60	31.10
TOTAL MONTHLY OUTFLOW (AF)	3.80	26.00	0.00	39.70
MAX. MEAN DAILY INFLOW (CFS)	1.90	1.40	0.40	3.10
TOTAL MONTHLY LOSSES (AF)	0.40	0.80	0.80	1.60
MIN. MEAN DAILY INFLOW (CFS)	0.00	0.00	0.00	0.10
MONTHLY STORAGE CHANGE (AF)	7.50	-5.90	15.70	-10.10

WATER YEAR 1989-90	JUNE	JULY	AUGUST	SEPTEMBER
TOTAL MONTHLY INFLOW (AF)	9.20	6.30	4.10	2.70
TOTAL MONTHLY OUTFLOW (AF)	0.00	0.00	0.00	0.00
MAX. MEAN DAILY INFLOW (CFS)	0.30	0.20	0.20	0.10
TOTAL MONTHLY LOSSES (AF)	1.90	3.00	2.50	2.60
MIN. MEAN DAILY INFLOW (CFS)	0.00	0.00	0.00	0.00
MONTHLY STORAGE CHANGE (AF)	7.30	3.30	1.50	0.00

SAN DIMAS DAM AND RESERVOIR

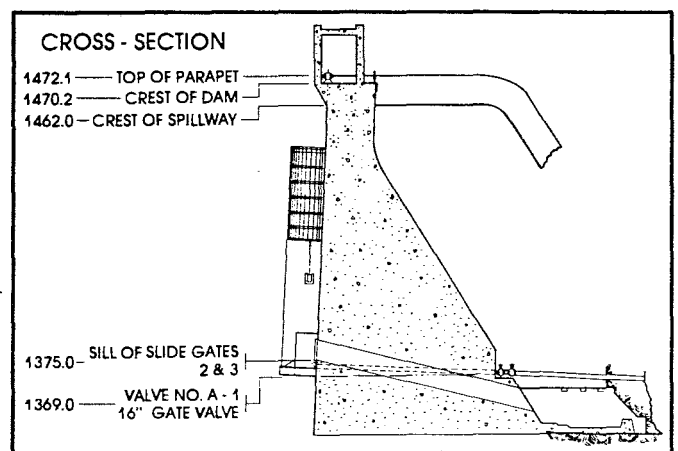
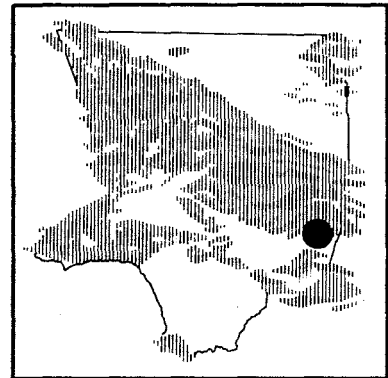
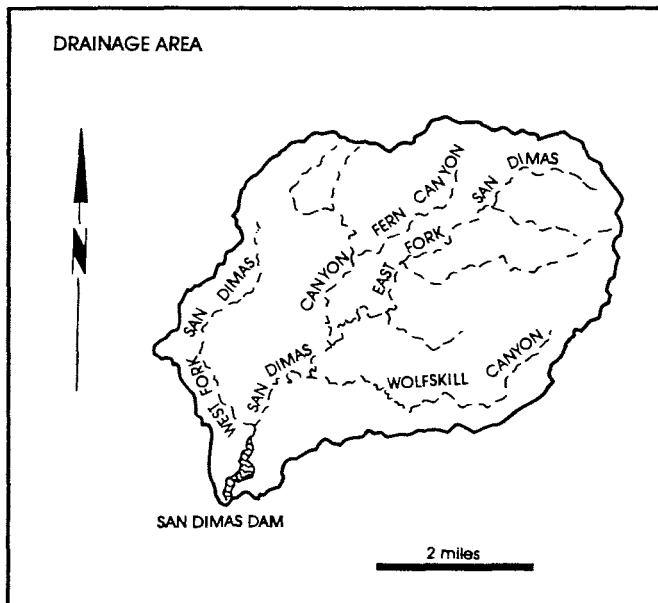

PURPOSE - Flood Control and Conservation.
 DATE CONSTRUCTED - Started November 1920. Completed September 1922.
 LOCATION - 3.0 miles northeast of San Dimas.
 DRAINAGE AREA - 16.2 square miles.
 CAPACITY - 1,515 acre - feet.
 SPILLWAY ELEVATION - 1,462.0 feet.

DAM OPERATION RECORD SUMMARY

MAX. PEAK INFLOW	93.18 CFS from 1700 on 02-17-90 to 1800 on 02-17-90
MAX. PEAK OUTFLOW	198.10 CFS from 1300 on 06-08-90 to 1315 on 06-08-90
MAX. W.S. ELEVATION	1435.07 feet on 06-03-90 STORAGE 721.95 ACRE-FEET
MIN. W.S. ELEVATION	1415.55 feet on varies STORAGE 273.43 ACRE-FEET

SAN DIMAS DAM OPERATION RECORD SUMMARY

WATER YEAR 1989-90	OCTOBER	NOVEMBER	DECEMBER	JANUARY
TOTAL MONTHLY INFLOW (AF)	19.50	27.80	32.40	93.20
TOTAL MONTHLY OUTFLOW (AF)	25.80	14.70	13.10	12.30
MAX. MEAN DAILY INFLOW (CFS)	0.60	1.40	1.20	4.30
TOTAL MONTHLY LOSSES (AF)	7.20	6.40	3.80	3.40
MIN. MEAN DAILY INFLOW (CFS)	0.00	0.00	0.10	0.20
MONTHLY STORAGE CHANGE (AF)	-13.50	6.70	15.40	77.60

WATER YEAR 1989-90	FEBRUARY	MARCH	APRIL	MAY
TOTAL MONTHLY INFLOW (AF)	180.70	128.90	92.00	78.40
TOTAL MONTHLY OUTFLOW (AF)	26.60	21.20	23.40	42.60
MAX. MEAN DAILY INFLOW (CFS)	27.80	5.70	3.00	5.00
TOTAL MONTHLY LOSSES (AF)	3.30	5.10	6.80	11.00
MIN. MEAN DAILY INFLOW (CFS)	0.20	1.40	0.50	0.30
MONTHLY STORAGE CHANGE (AF)	150.90	102.50	61.80	24.80

WATER YEAR 1989-90	JUNE	JULY	AUGUST	SEPTEMBER
TOTAL MONTHLY INFLOW (AF)	46.40	15.00	8.80	7.40
TOTAL MONTHLY OUTFLOW (AF)	212.80	43.80	12.10	13.90
MAX. MEAN DAILY INFLOW (CFS)	2.40	0.70	0.30	0.20
TOTAL MONTHLY LOSSES (AF)	13.40	17.60	14.00	10.80
MIN. MEAN DAILY INFLOW (CFS)	0.10	0.00	0.00	0.00
MONTHLY STORAGE CHANGE (AF)	-179.80	-46.40	-17.20	-17.30

PUDDINGSTONE DIVERSION DAM AND RESERVOIR

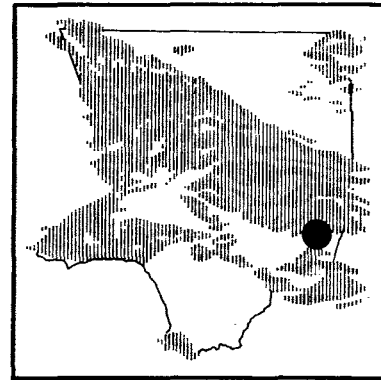
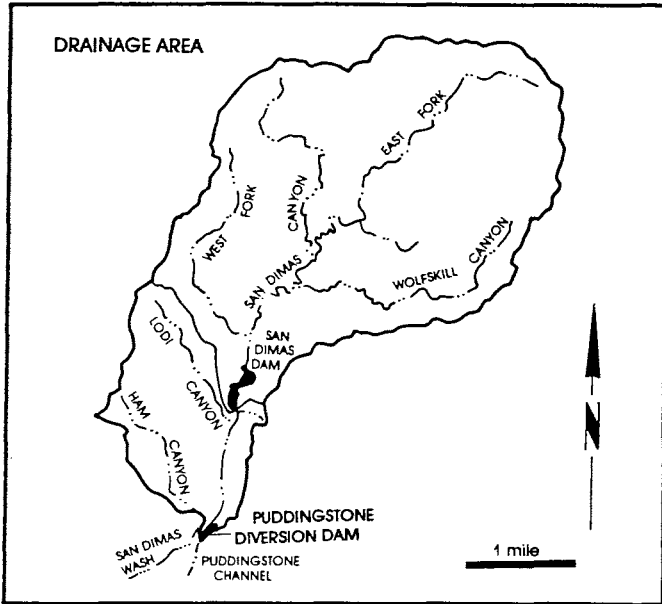

PURPOSE - Flood Control and Diversion of flow and Conservation.
 DATE CONSTRUCTED - Started September 1927. Completed July 1928.
 LOCATION - 2.0 miles northeast of San Dimas.
 DRAINAGE AREA - 3.7 square miles (uncontrolled)
 16.2 square miles (controlled)
 Total 19.9 square miles
 CAPACITY - 148 acre feet.
 SPILLWAY ELEVATION - 1,152.0 feet.

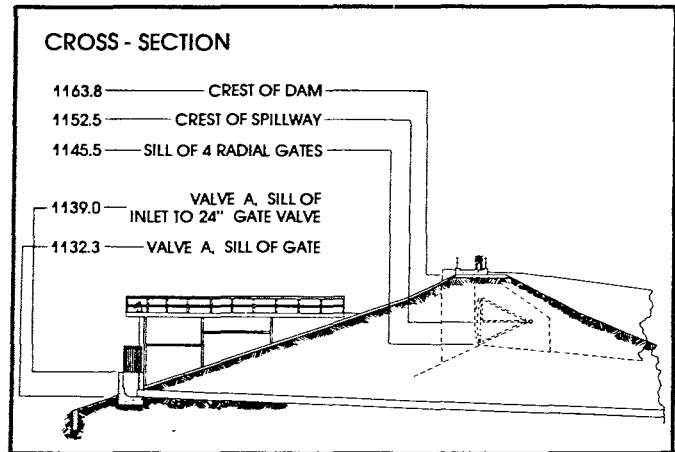

DAM OPERATION RECORD SUMMARY

MAX. PEAK INFLOW	77.56 CFS	from	1300	on	02-17-90	to	1400	on	02-17-90
MAX. PEAK OUTFLOW	19.50 CFS	from	0845	on	06-11-90	to	0900	on	06-11-90
MAX. W.S. ELEVATION	1149.30 feet	on	06-08-90	STORAGE	144.70	ACRE-FEET			
MIN. W.S. ELEVATION	1133.00 feet	on	Varies	STORAGE	0.00	ACRE-FEET			

PUDDINGSTONE DIVERSION DAM OPERATION RECORD SUMMARY

WATER YEAR 1989-90	OCTOBER	NOVEMBER	DECEMBER	JANUARY
TOTAL MONTHLY INFLOW (AF)	0.00	0.00	0.00	7.70
TOTAL MONTHLY OUTFLOW (AF)	0.00	0.00	0.00	1.00
MAX. MEAN DAILY INFLOW (CFS)	0.00	0.00	0.00	2.00
TOTAL MONTHLY LOSSES (AF)	0.00	0.00	0.00	6.70
MIN. MEAN DAILY INFLOW (CFS)	0.00	0.00	0.00	0.00
MONTHLY STORAGE CHANGE (AF)	0.00	0.00	0.00	0.00

WATER YEAR 1989-90	FEBRUARY	MARCH	APRIL	MAY
TOTAL MONTHLY INFLOW (AF)	40.00	0.00	21.80	9.50
TOTAL MONTHLY OUTFLOW (AF)	27.40	0.00	0.00	15.10
MAX. MEAN DAILY INFLOW (CFS)	17.30	0.00	4.90	1.90
TOTAL MONTHLY LOSSES (AF)	12.60	0.00	4.90	0.50
MIN. MEAN DAILY INFLOW (CFS)	0.00	0.00	0.00	0.00
MONTHLY STORAGE CHANGE (AF)	0.00	0.00	16.90	-6.10

WATER YEAR 1989-90	JUNE	JULY	AUGUST	SEPTEMBER
TOTAL MONTHLY INFLOW (AF)	149.00	0.00	0.00	0.00
TOTAL MONTHLY OUTFLOW (AF)	149.00	0.00	0.00	0.00
MAX. MEAN DAILY INFLOW (CFS)	48.20	0.00	0.00	0.00
TOTAL MONTHLY LOSSES (AF)	0.00	0.00	0.00	0.00
MIN. MEAN DAILY INFLOW (CFS)	0.00	0.00	0.00	0.00
MONTHLY STORAGE CHANGE (AF)	0.00	0.00	0.00	0.00

PUDDINGSTONE DAM AND RESERVOIR

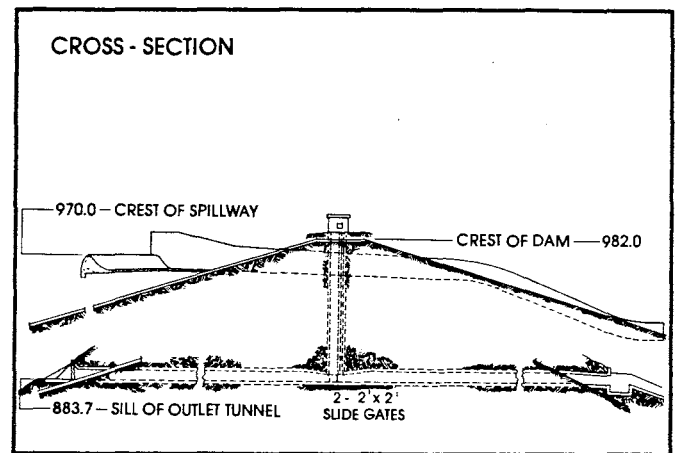
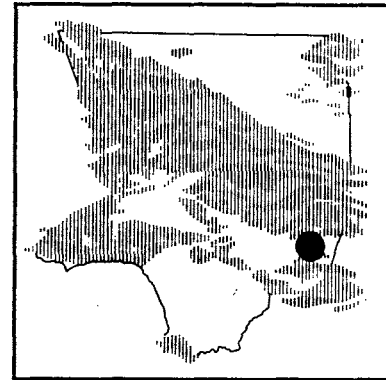
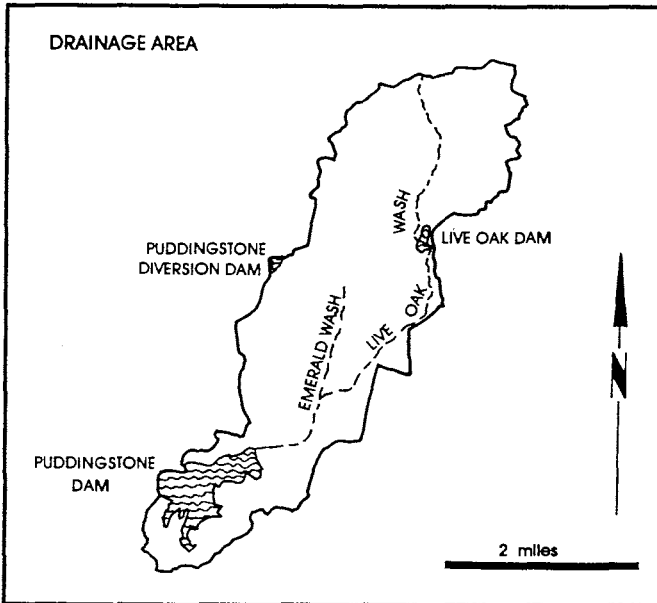

PURPOSE - Flood Control and Recreation.
DATE CONSTRUCTED - Started February 1925. Completed January 1928.
LOCATION - 1.0 mile south of San Dimas.
DRAINAGE AREA - 11.0 square miles (uncontrolled)
 22.1 square miles (controlled)
 Total 33.1 square miles
CAPACITY - 16,856 acre - feet.
SPILLWAY ELEVATION - 970.0 feet.

DAM OPERATION RECORD SUMMARY

MAX. PEAK INFLOW	682.77 CFS	from	1400	on	02-17-90	to	1500	on	02-17-90
MAX. PEAK OUTFLOW	161.00 CFS	from	1200	on	02-21-90	to	1215	on	02-21-90
MAX. W.S. ELEVATION	944.50 feet	on	02-18-90	STORAGE	7211.00	ACRE-FEET			
MIN. W.S. ELEVATION	939.74 feet	on	11-25-89	STORAGE	6004.78	ACRE-FEET			

PUDDINGSTONE DAM OPERATION RECORD SUMMARY

WATER YEAR 1989-90	OCTOBER	NOVEMBER	DECEMBER	JANUARY
TOTAL MONTHLY INFLOW (AF)	103.20	111.40	93.30	421.50
TOTAL MONTHLY OUTFLOW (AF)	18.60	10.50	12.40	14.70
MAX. MEAN DAILY INFLOW (CFS)	8.50	17.50	13.50	52.20
TOTAL MONTHLY LOSSES (AF)	101.80	93.50	70.90	59.90
MIN. MEAN DAILY INFLOW (CFS)	0.00	0.00	0.00	0.00
MONTHLY STORAGE CHANGE (AF)	-17.20	7.40	10.00	346.90

WATER YEA 1989-90	FEBRUARY	MARCH	APRIL	MAY
TOTAL MONTHLY INFLOW (AF)	867.10	99.40	194.00	296.50
TOTAL MONTHLY OUTFLOW (AF)	600.80	10.30	12.30	236.00
MAX. MEAN DAILY INFLOW (CFS)	234.60	4.00	24.20	67.10
TOTAL MONTHLY LOSSES (AF)	56.70	96.70	97.90	151.80
MIN. MEAN DAILY INFLOW (CFS)	0.00	0.30	0.10	0.40
MONTHLY STORAGE CHANGE (AF)	209.60	-7.60	83.80	-91.40

WATER YEAR 1989-90	JUNE	JULY	AUGUST	SEPTEMBER
TOTAL MONTHLY INFLOW (AF)	87.10	102.30	85.80	83.10
TOTAL MONTHLY OUTFLOW (AF)	14.70	14.90	16.10	15.30
MAX. MEAN DAILY INFLOW (CFS)	3.90	2.90	2.90	3.80
TOTAL MONTHLY LOSSES (AF)	189.00	228.00	194.90	174.50
MIN. MEAN DAILY INFLOW (CFS)	0.30	0.60	0.30	0.20
MONTHLY STORAGE CHANGE (AF)	-116.60	-140.50	-125.10	-106.60

LIVE OAK DAM AND RESERVOIR

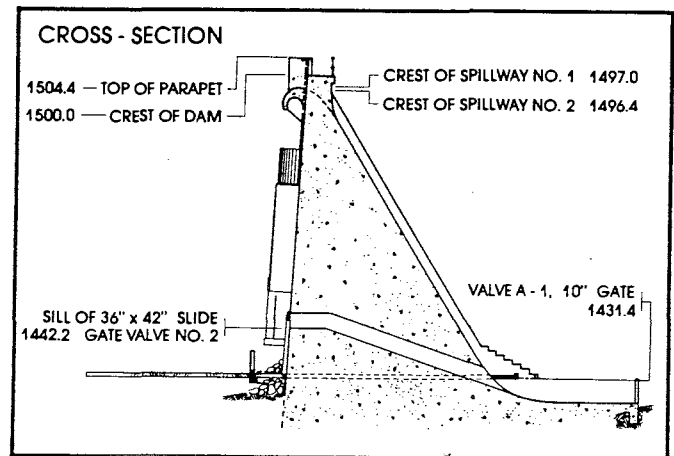
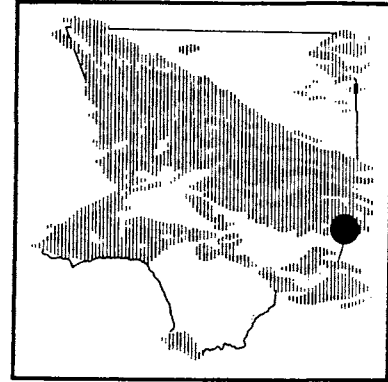
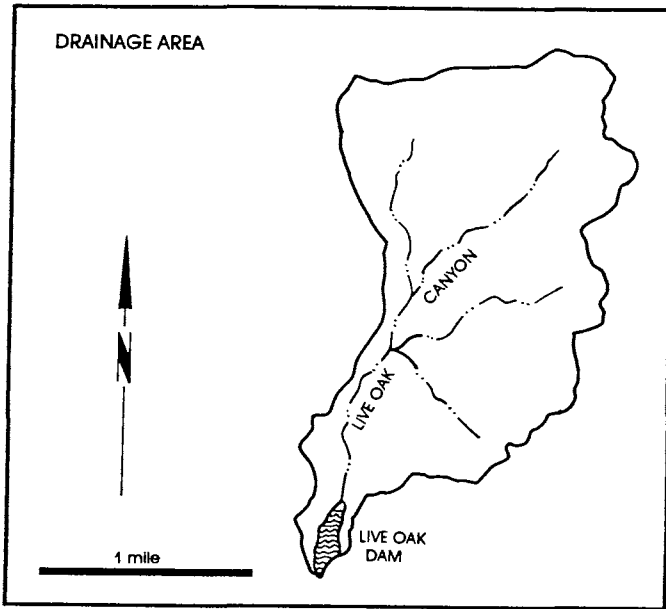

PURPOSE - Flood Control and Conservation.
 DATE CONSTRUCTED - Started August 1921. Completed November 1922.
 LOCATION - 2.5 miles northeast of La Verne.
 DRAINAGE AREA - 2.3 square miles.
 CAPACITY - 240 acre-feet.
 SPILLWAY ELEVATION - 1,496.0 feet.

DAM OPERATION RECORD SUMMARY

MAX. PEAK INFLOW	2.86 CFS from 1400 on 02-17-90 to 1500 on 02-17-90
MAX. PEAK OUTFLOW	2.94 CFS from 2100 on 05-28-90 to 2115 on 05-28-90
MAX. W.S. ELEVATION	1441.06 feet on 02-18-90 STORAGE 0.07 ACRE-FEET
MIN. W.S. ELEVATION	1440.00 feet on varies STORAGE 0.00 ACRE-FEET

LIVE OAK DAM OPERATION RECORD SUMMARY

WATER YEAR 1989-90	OCTOBER	NOVEMBER	DECEMBER	JANUARY
TOTAL MONTHLY INFLOW (AF)	0.00	0.00	0.00	0.00
TOTAL MONTHLY OUTFLOW (AF)	0.00	0.00	0.00	0.00
MAX. MEAN DAILY INFLOW (CFS)	0.00	0.00	0.00	0.00
TOTAL MONTHLY LOSSES (AF)	0.00	0.00	0.00	0.00
MIN. MEAN DAILY INFLOW (CFS)	0.00	0.00	0.00	0.00
MONTHLY STORAGE CHANGE (AF)	0.00	0.00	0.00	0.00

WATER YEAR 1989-90	FEBRUARY	MARCH	APRIL	MAY
TOTAL MONTHLY INFLOW (AF)	7.50	7.70	9.10	16.30
TOTAL MONTHLY OUTFLOW (AF)	7.50	7.70	9.10	16.30
MAX. MEAN DAILY INFLOW (CFS)	2.00	0.30	0.30	1.30
TOTAL MONTHLY LOSSES (AF)	0.00	0.00	0.00	0.00
MIN. MEAN DAILY INFLOW (CFS)	0.00	0.00	0.10	0.10
MONTHLY STORAGE CHANGE (AF)	0.00	0.00	0.00	0.00

WATER YEAR 1989-90	JUNE	JULY	AUGUST	SEPTEMBER
TOTAL MONTHLY INFLOW (AF)	10.70	0.00	0.00	0.00
TOTAL MONTHLY OUTFLOW (AF)	10.70	0.00	0.00	0.00
MAX. MEAN DAILY INFLOW (CFS)	0.50	0.00	0.00	0.00
TOTAL MONTHLY LOSSES (AF)	0.00	0.00	0.00	0.00
MIN. MEAN DAILY INFLOW (CFS)	0.00	0.00	0.00	0.00
MONTHLY STORAGE CHANGE (AF)	0.00	0.00	0.00	0.00

THOMPSON CREEK DAM AND RESERVOIR

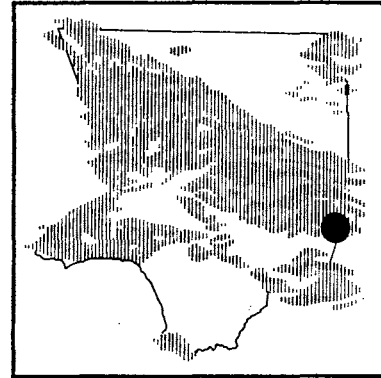
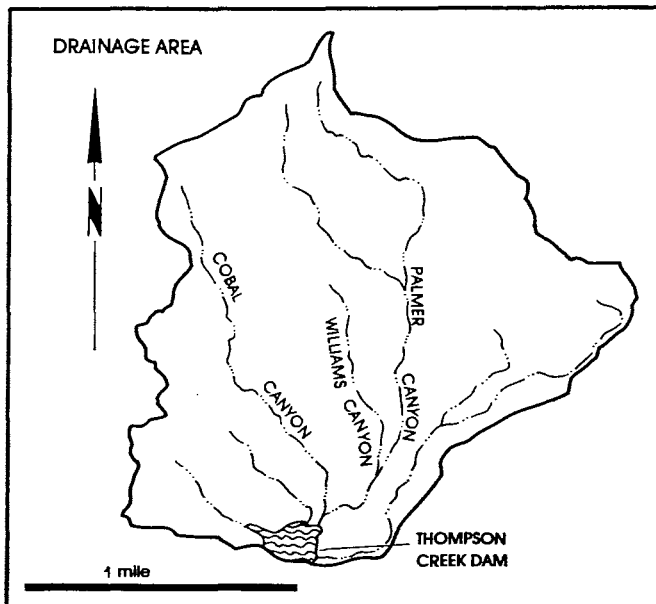

PURPOSE - Flood Control and Conservation.
 DATE CONSTRUCTED - Started September 1925. Completed March 1928.
 LOCATION - 3.0 miles north of Claremont.
 DRAINAGE AREA - 3.5 square miles.
 CAPACITY - 447.5 acre - feet.
 SPILLWAY ELEVATION - 1,634 feet.

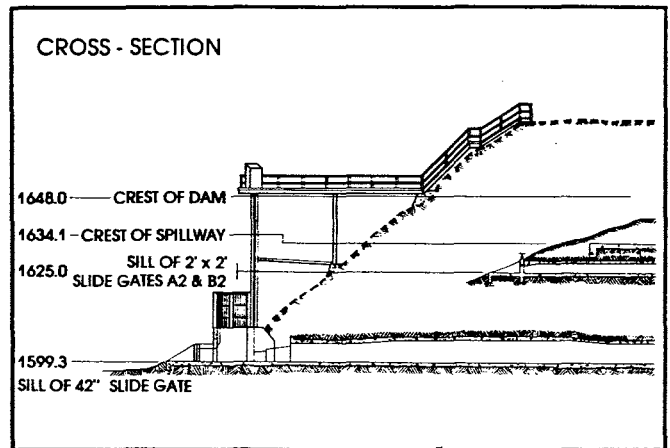

DAM OPERATION RECORD SUMMARY

MAX. PEAK INFLOW	0.80 CFS from 1200 on 02-17-90 to 1300 on 02-17-90
MAX. PEAK OUTFLOW	0.80 CFS from 1600 on 02-17-90 to 1615 on 02-17-90
MAX. W.S. ELEVATION	1600.00 feet on varies STORAGE 0.00 ACRE-FEET
MIN. W.S. ELEVATION	1600.00 feet on varies STORAGE 0.00 ACRE-FEET

THOMPSON CREEK DAM OPERATION RECORD SUMMARY

WATER YEAR 1989-90	OCTOBER	NOVEMBER	DECEMBER	JANUARY
TOTAL MONTHLY INFLOW (AF)	0.00	0.00	0.00	3.80
TOTAL MONTHLY OUTFLOW (AF)	0.00	0.00	0.00	3.80
MAX. MEAN DAILY INFLOW (CFS)	0.00	0.00	0.00	0.50
TOTAL MONTHLY LOSSES (AF)	0.00	0.00	0.00	0.00
MIN. MEAN DAILY INFLOW (CFS)	0.00	0.00	0.00	0.00
MONTHLY STORAGE CHANGE (AF)	0.00	0.00	0.00	0.00

WATER YEAR 1989-90	FEBRUARY	MARCH	APRIL	MAY
TOTAL MONTHLY INFLOW (AF)	1.80	0.00	0.00	0.00
TOTAL MONTHLY OUTFLOW (AF)	1.80	0.00	0.00	0.00
MAX. MEAN DAILY INFLOW (CFS)	0.40	0.00	0.00	0.00
TOTAL MONTHLY LOSSES (AF)	0.00	0.00	0.00	0.00
MIN. MEAN DAILY INFLOW (CFS)	0.00	0.00	0.00	0.00
MONTHLY STORAGE CHANGE (AF)	0.00	0.00	0.00	0.00

WATER YEAR 1989-90	JUNE	JULY	AUGUST	SEPTEMBER
TOTAL MONTHLY INFLOW (AF)	0.00	0.00	0.00	0.00
TOTAL MONTHLY OUTFLOW (AF)	0.00	0.00	0.00	0.00
MAX. MEAN DAILY INFLOW (CFS)	0.00	0.00	0.00	0.00
TOTAL MONTHLY LOSSES (AF)	0.00	0.00	0.00	0.00
MIN. MEAN DAILY INFLOW (CFS)	0.00	0.00	0.00	0.00
MONTHLY STORAGE CHANGE (AF)	0.00	0.00	0.00	0.00

EROSION CONTROL

EROSION CONTROL

Each year eroded material in various forms (trees, rock, sand, etc.) flows out of the mountain watersheds of Los Angeles County. In an effort to control this potentially disruptive force, the Department maintains a series of debris basins in canyon mouths and upstream stabilization structures in selected watersheds.

PURPOSE

The purpose of a debris basin is to entrap the debris flows emanating from the canyon and let the relatively desilted water pass into flood control channels.

From 1989 to 1990, the number of debris basins was changed from 114 to 115 by adding one new basin. This gives a total capacity of approximately 7,613,700 cubic yards.

Records of sediment inflow at individual debris basins and amounts excavated and removed are available in the Hydraulic/Water Conservation Division.

STABILIZATION STRUCTURES

Stabilization structures are constructed to control erosion in natural canyons. They serve to prevent downcutting by stabilizing alluvium deposits. In addition, they store debris generated by the watershed and serve to stabilize side banks, reducing side slope sloughing and bank erosion.

The Department maintains 225 stabilization structures in 47 major watersheds. No structures have been constructed since the 1973-74 water year.

EMERGENCY STRUCTURES

Emergency structures (rail and timber, and crib type) have been constructed to entrap the debris inflow from burned watersheds. They serve to protect improvements (road, channel, residence, etc.) located immediately downstream of the watersheds. Currently, 39 emergency structures exist with a total maximum capacity of 349,500 cubic yards. Two major fires, (those over 500 acres), burned 1,500 acres in this water year and are shown on page PE2.

SEDIMENT REMOVAL FROM RESERVOIRS

Sediment deposition in reservoirs reduces the storage capacities and adversely affects flood control and water conservation efforts. Sediment removal is periodically necessary and is generally an expensive effort due to large quantities, the need to deal with water inflows, and in several cases, remote locations and limited accessibility for equipment.

Where practical, the Department encourages sediment removal by permittees at no cost to the Department such as at Eaton Wash and Devil's Gate Dams.

The Department presently is studying the feasibility of various methods for the removal and long-term management of sediment in the three reservoirs in San Gabriel Canyon. These three currently contain about 36 million cubic yards - about three-quarters of the cumulative volume of sediment currently behind all dams under the Department's control.

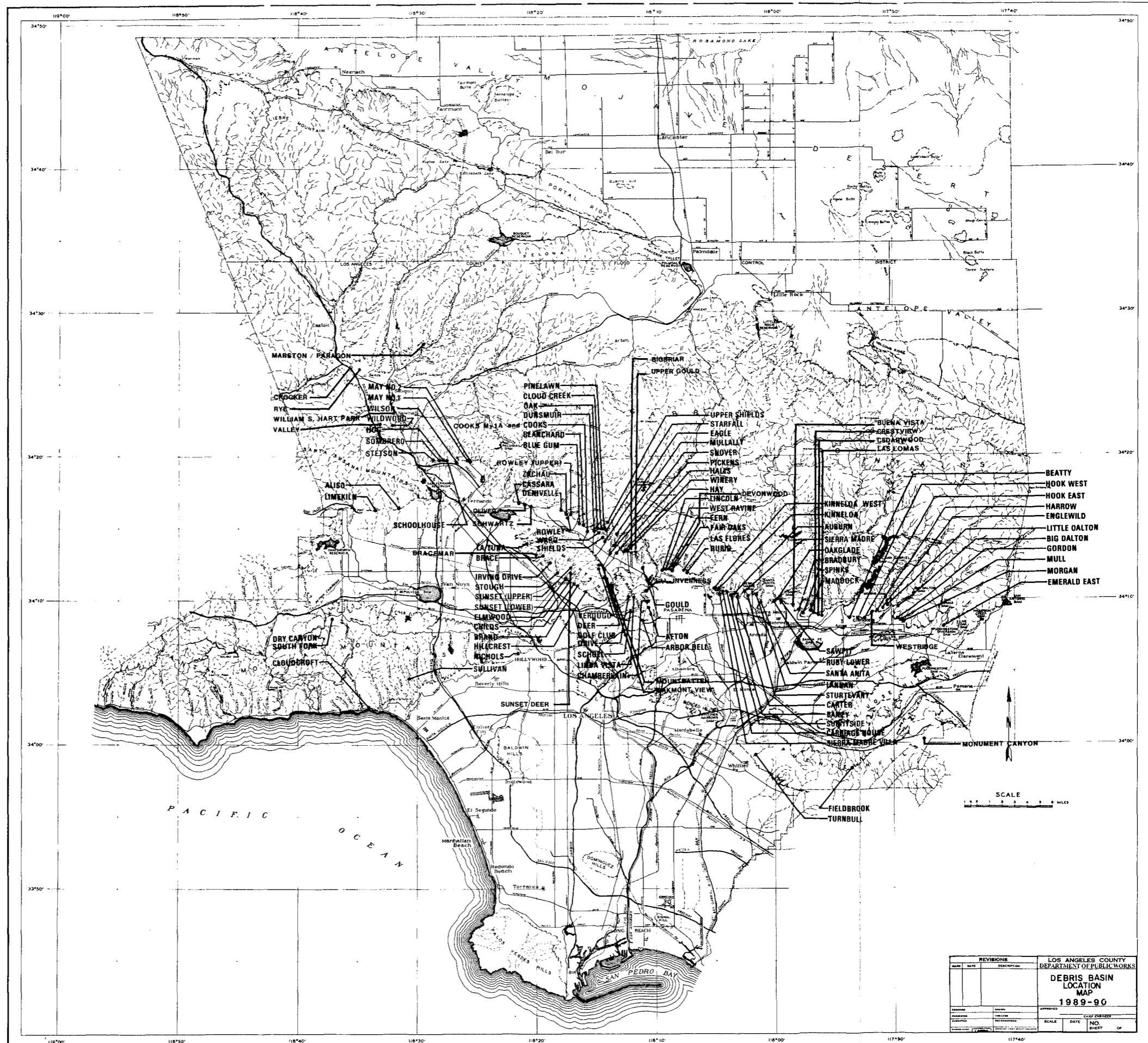

BEATTY
HOOK WEST
HOOK EAST
HARROW
ENGLEWILD
LITTLE DALTON
BIG DALTON
GORDON
MULL
MORGAN
EMERALD EAST

REVISIONS		LOS ANGELES COUNTY DEPARTMENT OF PUBLIC WORKS		
NO.	DATE	BY	DESCRIPTION	
DEBRIS BASIN LOCATION MAP 1989-90				APPROVED _____
				DATE _____
SCALE _____	DATE _____	NO. _____	OF _____	

DEBRIS BASIN - DESIGN DATA

Including 1989-1990 Season

Compiled by: Hydraulic and Water Conservation
Division - Sedimentation Section

DATA SHEET A

Date: October 1, 1990

FILE: DSA90.WK1

DEBRIS BASIN	FIRST DEBRIS SEASON	UNCONTROLLED DRAINAGE AREA ABOVE BASIN SQ. MI.	BOTTOM ELEV. AT MAX CAP. FT.	ELEV PORT INVERT FT. (1)	ELEV. SPILLWAY CREST	WIDTH SPILLWAY FT.	ELEV. CREST OF DAM FT.	MAX. DEB. CAP. CU. YDS.
Afton	1974 - 75	0.06	1032.2	1030.0	1041.4	20.0	1046.6	7,200
Aliso	1970 - 71	2.77	1108.0	1108.4	1120.0	70.0	1134.0	41,700 (8)
Arbor Dell	1971 - 72	0.11	899.3	898.4	913.0	22.9	919.6	12,400
Auburn	1954 - 55	0.19	1263.9	1263.0	1275.0	30.0	1283.0	33,700
Bailey	1945 - 46	0.60	1122.5	1123.1	1155.0	30.0	1166.0	128,800
Beatty	1970 - 71	0.27	800.0	800.0	807.0	32.0	815.5	43,000
Bigbriar	1971 - 72	0.02	1898.3	1896.0	1910.0	14.0	1910.8	3,100
Big Dalton	1959 - 60	2.94	1102.0	1101.9 (3)	1131.5	116.0	1148.7	517,800
Blanchard	1968 - 69	0.47	2026.0	2026.0	2053.5	40.0	2065.0	74,500
Blue Gum	1968 - 69	0.19	2020.0	2020.0	2042.0	25.0	2053.0	39,600
Brace	1971 - 72	0.29	1189.7	1189.7	1194.5	20.0	1203.3	27,500
Bracemar	1971 - 72	0.01	1140.0	1140.0	1145.5	8.0	1148.0	700 (11)
Bradbury	1954 - 55	0.68	912.5	913.1	920.0	58.0	928.0	89,800
Brand	1935 - 36	1.04	859.0	860.0	890.0	60.0	903.0	170,700
Buena Vista	1985 - 86	0.10	978.7	978.7	992.2	39.0	997.7	21,400
Carriage House	1970 - 71	0.03	1350.3	1350.0	1362.9	15.0	1366.8	10,400
Carter	1954 - 55	0.12	1222.0	1223.2	1238.2	30.0	1245.0	18,700
Cassara	1976 - 77	0.21	1271.5	1271.5	1291.7	66.0	1295.4	37,000
Cedarwood	1983 - 84	0.0075	866.8	867.5	872.3	10.0	876.0	900
Chamberlain	1974 - 75	0.04	1084.6	1084.0	1097.5	20.0	1101.3	4,700
Childs	1963 - 64	0.30	1022.0	1022.0	1058.8	23.0	1071.0	50,400
Cloud Creek	1972 - 73	0.02	2347.2	2350.5	2360.0	(5)	2362.0	6,200
Cloudcroft	1973 - 74	0.21	313.9	315.0	329.5	36.0	329.5	34,700
Cooks	1951 - 52	0.58	2058.0	2058.0	2082.9	48.0	2092.0	85,600
Cooks M-1A	1975 - 76	(15)	(15)	(15)	(15)	(15)	(15)	(15)
Crestview	1983 - 84	0.03	864.4	864.0	886.2	20.0	891.7	5,900
Crocker	1983 - 84	0.67	1059.9	1064.2	1069.8	36.0	1077.0	39,200
Deer	1954 - 55	0.59	1185.4	1185.0	1201.0	56.0	1209.6	56,600
Denivelle	1976 - 77	0.18	1471.0	1471.0	1479.3	46.0	1483.3	8,200
Devonwood	1981 - 82	0.05	1899.0	1899.0	1915.8	22.0	1921.5	6,400
Dry Canyon-South Fork	1978 - 79	1.05	1062.8	1062.5	1074.8	32.0	1079.3	7,900
Dunsmuir	1935 - 36	0.84	2228.0	2227.7	2257.2	60.0	2272.2	101,900
Eagle	1936 - 37	0.48	1848.3	1844.3	1880.2	60.0	1895.2	62,400
Elmwood	1964 - 65	0.31	912.0	911.5	938.0	22.0	952.0	66,400
Emerald-East	1964 - 65	0.32	1185.1	1181.1	1192.0	30.0	1204.0	13,200
Englewild	1961 - 62	0.40	1274.9	1275.0	1297.0	50.0	1300.0	50,400
Fair Oaks	1935 - 36	0.21	1544.0	1544.0	1561.9	(6)	1566.5	23,800
Fern	1935 - 36	0.31	1438.7	1462.4	1470.2	25.0	1480.5	30,600
Fieldbrook	1974 - 75	0.35	712.7	713.0	718.0	28.0	722.3	2,800
Golf Club Drive	1970 - 71	0.32	880.7	880.7	902.0	36.7	915.0	14,700
Gordon	1973 - 74	0.18	1075.7	1075.0	1088.0	22.0	1096.0	16,800

DEBRIS BASIN - DESIGN DATA

Including 1989-1990 Season

Compiled by: Hydraulic and Water Conservation
Division - Sedimentation Section

DATA SHEET A

Date: October 1, 1990

FILE: DSA90.WK1

DEBRIS BASIN	FIRST DEBRIS SEASON	UNCONTROLLED DRAINAGE AREA ABOVE BASIN SQ. MI.	BOTTOM ELEV. AT MAX CAP. FT.	ELEV PORT INVERT FT. (1)	ELEV. SPILLWAY CREST	WIDTH SPILLWAY FT.	ELEV. CREST OF DAM FT.	MAX. DEB. CAP. CU. YDS.
Gould	1947 - 48	0.29	1529.5	1528.2	1548.0	55.0	1548.0	49,600
Gould (Upper)	1976 - 77	0.18	1863.9	1863.9	1897.7	32.0 (17)	1901.0	52,300 16
Halls	1935 - 36	0.86	1641.6	1641.8	1661.3	131.0	1664.0	89,400
Harrow	1958 - 59	0.43	1254.8	1255.0	1269.0	40.0	1277.8	68,000
Hay	1936 - 37	0.20	1875.4	1901.0	1905.0	36.0	1915.0	34,400
Hillcrest	1962 - 63	0.35	863.5	863.5	885.0	18.0	901.0	57,800
Hog	1969 - 70	0.30	1520.3	1520.0	1535.0	32.0	1547.0	39,600
Hook East	1968 - 69	0.18	1197.5	1198.0	1210.9	37.0	1215.0	30,700
Hook West	1970 - 71	0.17	1144.8	1145.0	1158.9	40.0	1167.0	21,600
Inverness	1982 - 83	0.03	1253.0	1252.9	1256.7	20.0	1261.0	3,300
Irving Drive	1974 - 75	0.03	905.8	905.0	915.3	12.0	920.0	2,100
Kinneloa	1964 - 65	0.20	1370.0	1370.0	1388.0	40.0	1395.0	17,200 18
Kinneloa West Branch	1966 - 67	0.16	1384.9	1385.0	1400.0	22.0	1408.5	23,600 (18)
Lannan	1954 - 55	0.25	1016.0	1015.0	1035.8	14.0	1043.0	36,700
La Tuna	1955 - 56	5.34	1109.0	1110.0	1140.0	75.0	1157.0	495,300
Las Flores	1935 - 36	0.45	1685.1	(9)	1715.6	50.0	1726.4	57,600
Las Lomas	1983 - 84	0.07	895.4	896.0	906.6	24.0	911.0	9,300
Limekiln	1963 - 64	3.72	990.0	992.0	1003.0	77.0	1019.0	171,600
Lincoln	1935 - 36	0.50	1275.8	1276.0	1304.0	56.0	1322.5	38,400
Linda Vista	1970 - 71	0.37	979.5	979.5	989.8	40.0	995.7	3,200
Little Dalton	1959 - 60	3.31	1140.0	1139.5	1186.0	84.0	1200.2	656,500
Maddock	1954 - 55	0.25	888.6	891.8	901.0	36.0	904.0	45,900
Marston/Paragon	1988 - 89	0.20	(10)	(10)	(10)	(10)	(10)	(10)
May No. 1	1953 - 54	0.70	1665.9	1666.0	1684.0	60.0	1692.5	64,000
May No. 2	1953 - 54	0.09	1663.4	1663.5 (2)	1669.5	20.0	1674.0	10,000
Monument	1981 - 82	0.11	943.8	942.3	950.0	12.0	954.0	6,800
Morgan	1964 - 65	0.60	1135.0	1135.0	1158.0	45.0	1167.0	51,100
Mountbatten	1983 - 84	0.01	1136.2	1135.5	1140.9	20.0	1141.0	1,400
Mull	1973 - 74	0.15	1146.9	1147.0	1154.0	20.0	1165.0	16,000
Mullally (12)	1974 - 75	0.34	2420.0	2420.0	2435.4	42.0	2439.6	12,000
Nichols	1937 - 38	0.44	481.0	481.0	485.1	50.0	495.0	13,100
Oak	1975 - 76	0.05	2145.7	2145.7	2151.8	50.0	2156.2	8,700
Oakglade	1974 - 75	0.06	1274.6	1280.0	1290.0	20.0	1296.0	12,300
Oakmont View Drive	1984 - 85	0.02	1315.5	1315.5	1327.5	20.0	1327.5	3,400
Oliver	1989 - 90	0.18	1253.4	1253.4	1278.0	41.0	1283.3	32,100
Pickens	1935 - 36	1.50	1564.0	1564.0	1600.0	123.0	1613.0	125,115
Pinelawn	1973 - 74	0.02	2431.0	2430.5	2443.0	(7)	2448.5	3,200
Rowley	1953 - 54	0.27	1701.6	1703.6	1714.0	60.0	1722.0	43,100 16
Rowley (Upper)	1976 - 77	0.31	1926.0	1926.0	1946.0	42.0	1951.3	28,800
Rubio	1943 - 44	1.26	1582.1	1582.1	1608.3	59.0	1625.5	127,200
Ruby (Lower)	1955 - 56	0.28	810.8	809.6	828.0	45.0	833.0	28,600

DEBRIS BASIN - DESIGN DATA

Including 1989-1990 Season

Compiled by: Hydraulic and Water Conservation
Division - Sedimentation Section

DATA SHEET A

Date: October 1, 1990

FILE: DSA90.WK1

DEBRIS BASIN	FIRST DEBRIS SEASON	UNCONTROLLED DRAINAGE AREA ABOVE BASIN SQ. MI.	BOTTOM ELEV. AT MAX CAP. FT.	ELEV PORT INVERT FT. (1)	ELEV. SPILLWAY CREST	WIDTH SPILLWAY FT.	ELEV. CREST. OF DAM FT.	MAX. DEB. CAP. CU. YDS.
Rye	1981 - 82	1.11	1073.9	1073.8	1077.7	58.2	1081.5	19,100
Santa Anita	1959 - 60	1.70	748.5	748.5 (3)	774.7	160.0	796.0	394,600 16
Sawpit	1954 - 55	2.78	928.5	933.4	982.0	110.0	1000.0	644,500
Scholl	1945 - 46	0.66	950.0	950.0 (2)	956.0	76.0	966.0	9,300 16
Schoolhouse	1962 - 63	0.28	1459.6	1460.0	1478.5	20.0	1491.0	67,700
Schwartz	1976 - 77	0.25	1296.0	1294.7	1313.2	35.0	1319.0	45,400
Shields	1937 - 38	0.03	2030.0	2050.0	2058.1	30.0	2070.2	34,800
Sierra Madre Dam (14)	1927 - 28	2.39	1119.5	1119.5	1172.5	62.5	1175.0	133,600
Sierra Madre Villa	1957 - 58	1.46	1069.2	1069.2	1088.9	48.0	1102.5	402,700
Snover	1936 - 37	0.23	1858.0	1874.4	1879.0	40.0	1893.7	23,400
Sombrero	1969 - 70	1.06	1539.6	1540.0	1564.8	45.0	1580.0	87,900
Spinks	1958 - 59	0.42	750.0	750.0	761.5	40.0	765.9	56,000
Starfall	1973 - 74	0.13	2428.0	2428.0	2441.5	30.0	2446.5	18,400
Stetson	1969 - 70	0.29	1556.0	1555.0	1570.0	32.0	1570.0	41,300 16
Stough	1940 - 41	1.65	1006.0	1005.8	1031.5 (4)	100.0	1043.5	181,200
Sturtevant	1967 - 68	0.03	975.0	971.0	983.6	8.0	990.0	2,300
Sullivan	1970 - 71	2.38	570.0	570.0	586.6	50.0	599.3	51,000
Sunnyside	1970 - 71	0.02	1290.0	1290.0	1299.5	15.0	1303.8	4,300
Sunset Canyon-Deer	1982 - 83	0.20	1382.4	1380.5	1401.8	24.0	1409.1	6,400
Sunset (Lower)	1963 - 64	0.65	1003.8	994.5	1040.0	40.0	1056.0	160,600
Sunset (Upper)	1928 - 29	0.44	1574.2	1574.0	1603.7	75.0	1610.1	15,900
Turnbull	1952 - 53	0.99	480.0	475.6	492.0	40.0	503.0	20,300
Upper Shields (12)	1976 - 77	0.20	2505.0	2502.0	2518.8	29.5	2524.0	5,600
Valley	1987 - 88	0.22	1351.0	(10)	(10)	31.0	1365.0	4,000
Verdugo	1935 - 36	3.09	1109.5	1110.0	1119.7	145.0	1131.0	131,000
Ward	1956 - 57	0.12	2021.8	2022.0	2043.0	58.0	2035.3	26,400
West Ravine	1935 - 36	0.25	1470.0	(9)	1501.9	20.0	1505.5	46,800
Westridge	1974 - 75	0.02	894.0	894.0	901.0	10.7	906.0	1,400
Wildwood	1967 - 68	0.65	1340.3	(9)	1354.0	50.0	1360.0	22,500
William S. Hart Park	1983 - 84	0.09	1284.0	1280.0	1290.0	19.0	1293.0	2,400
Wilson	1962 - 63	2.58	1517.3	1493.0	1526.0	60.0	1543.0	316,900
Winery	1968 - 69	0.18	1920.0	1920.0	1935.0	20.0	1945.0	29,200
Zachau	1956 - 57	0.35	1803.4	1803.1	1817.5	44.0	1823.0	48,100

DEBRIS BASIN - DESIGN DATA

Including 1989-1990 Season

Compiled by: Hydraulic and Water Conservation
Division - Sedimentation Section

Date: October 1, 1990

DATA SHEET A

- (1) LOWEST CLEAR WATER OUTLET, NOT SPILLWAY.
- (2) ELEVATION OF SPILLWAY NOTCH.
- (3) FLOW LINE OF SLUICeway.
- (4) ELEVATION OF SPILLWAY INTO OUTLET CHANNEL. ELEVATION OF OVERFLOW SPILLWAY 1036.9 FEET.
- (5) ONE 30-INCH REINFORCED CONCRETE PIPE.
- (6) FOUR 36-INCH CORRUGATED METAL PIPES.
- (7) ONE 36-INCH REINFORCED CONCRETE PIPE.
- (8) DEBRIS CAPACITY AVAILABLE WITHIN RIGHT OF WAY LIMITS.
- (9) PIT-TYPE BASIN.
- (10) INFORMATION UNAVAILABLE.
- (11) MAXIMUM CAPACITY MAY BE LESS THAN SHOWN AND IS BEING REVIEWED. FIELD INSPECTION SUGGESTS BASIN IS NEAR ITS FULLEST POSSIBLE CAPACITY.
- (12) SPECIAL CLEANOUT REQUIRED DUE TO LIMITED STORAGE.
- (13) TRANSFERRED FOR MAINTENANCE AFTER THE 87-88 STORM SEASON. FIRST DEBRIS SEASON WILL BE 88-89.
- (14) CLEANOUT WHEN DEBRIS REACHES OR EXCEEDS ELEV. 1128.9 AGAINST FACE OF DAM.
- (15) VALUES ARE COMBINED WITH COOKS DEBRIS BASIN.
- (16) VALUES ARE BASED ON RECENTLY APPROVED CUTPLANS.
- (17) SPILLWAY IS STREET.
- (18) CLEANED FALL OF 1990.

DEBRIS BASIN - DEBRIS PRODUCTION HISTORY

Including 1989 - 1990

Compiled by: Hydraulic and Water Conservation
Division - Sedimentation Section

Date: October 1, 1990

FILE: DSB90.WK1

DATA SHEET B

DEBRIS BASIN	NUMBER OF SEASONS	TOTAL DEBRIS DEPOSITED CU. YDS. (1)	MAXIMUM SEASONAL DEBRIS PRODUCTION		ESTIMATED CONDITIONS		
			CU. YDS.	SEASON	DEBRIS STORED CU. YD.	CAPACITY AVAILABLE CU. YD. PER CENT	
Afton	16	1,030	800	1974-75	-114	7,314	102
Aliso	20	134,730	30,700	1982-83	-1910	43,610	105 (5)
Arbor Dell	19	1,397	800	1979-80	368	12,432	97
Auburn	36	87,386	20,100	1961-62	13	33,687	100
Bailey	45	238,794	91,000	1979-80	1240	127,537	99
Beatty	20	13,297	7,600	1979-80	3236	39,764	92
Bigbriar	19	2,004	623	1987-88	-193	3,293	106
Big Dalton	31	833,003	296,700	1968-69	5184	512,622	99
Blanchard	22	68,196	36,600	1977-78	159	74,374	100
Blue Gum	22	37,572	19,100	1977-78	1473	38,127	96
Brace	19	35,621	12,000	1977-78	-18	27,518	100
Bracemar	19	664 (7)	283	1980-81	-228	888	135 (9)
Bradbury	36	267,430	70,200	1968-69	1966	88,534	98
Brand	55	248,895	53,100	1977-78	21640	149,060	87
Buena Vista	5	38	38	1987-88	-226	21,674	85
Carriage House	20	4,742	3,400	1979-80	-341	10,741	103
Carter	36	36,890	12,600	1979-80	213	18,487	99
Cassara	14	25,583	16,800	1977-78	3384	33,616	91
Cedarwood	7	(6)	(6)	(6)	3	857	100
Chamberlain	16	556	300	1974-75	-105	6,705	102
Childs	27	45,220	10,700	1980-81	4227	46,200	92
Cloud Creek	18	3,262	1,800	1977-78	650	14,150	96
Cloudcroft	17	12,290	6,100	1973-74	1627	33,073	95
Cooks	39	166,864 (3)	61,200	1977-78	-4466	82,866	106
Cooks M-1A	15	(13)	(13)	(13)	(13)	(13)	(13)
Crestview	7	(6)	(6)	(6)	-45	5,945	101
Crocker	7	(6)	(6)	(6)	4	39,196	100
Deer	36	156,948	44,200	1968-69	6873	49,727	88
Denivelle	14	8,660	5,500	1977-78	559	7,641	93
Devonwood	9	132	100	1982-83	-296	6,696	105
Dry Canyon-South Fork	12	6,003	5,300	1979-80	111	7,789	99
Dunsmuir	55	349,183	86,200	1977-78	2676	108,224	98
Eagle	54	200,286	41,700	1937-38	7072	55,328	89
Elmwood	26	52,781	16,100	1980-81	3643	59,557	94
Emerald-East	26	8,959	1,800	1985-86	53	13,147	100
Englewild	29	85,119 (2)	60,200 (2)	1968-69	521	49,879	99
Fair Oaks	55	109,020	15,700	1935-36	-2463	26,263	110
Fern	55	159,554	23,900	1968-69	1940	28,660	94
Fieldbrook	16	1,354	500	1977-78	507	2,293	82
Golf Club Drive	20	30,157	11,600	1979-80	323	14,377	98
Gordon	17	4,485	3,800	1977-78	-181	16,981	101

DEBRIS BASIN - DEBRIS PRODUCTION HISTORY

Including 1989 - 1990

Compiled by: Hydraulic and Water Conservation
Division - Sedimentation Section

Date: October 1, 1990

FILE: DSB90.WK1

DATA SHEET B

DEBRIS BASIN	NUMBER OF SEASONS	TOTAL DEBRIS DEPOSITED CU. YDS. (1)	MAXIMUM SEASONAL DEBRIS PRODUCTION		ESTIMATED CONDITIONS		
			CU. YDS.	SEASON	DEBRIS STORED CU. YD.	CAPACITY AVAILABLE CU. YD. PER CENT	
Gould	43	115,091	18,000	1965-66	3700	45,900	93
Gould (Upper)	14	25,444	10,100	1977-78	-161	52,161	100
Halls	55	569,156	102,100	1937-38	1173	88,227	99
Harrow	32	78,297 (2)	63,400 (2)	1968-69	-4791	72,791	107
Hay	54	67,952	18,200	1937-38	738	33,662	98
Hillcrest	28	48,589	11,700	1964-65	6005	51,785	90
Hog	21	6,500	3,900	1977-78	56	39,544	100
Hook East	22	45,709 (2)	40,200 (2)	1968-69	-32	30,732	100
Hook West	20	6,537	3,600	1979-80	5012	34,588	87 14
Inverness	8	265	300	1982-83	365	2,935	89
Irving Drive	16	1,244	600	1980-81	90	2,010	96
Kinneloa	26	48,929 (2)	17,600 (2)	1968-69	-536	17,736	103
Kinneloa West Branch	24	59,055 (2)	22,200 (2)	1968-69	4242	18,732	79 (14)
Lannan	36	84,067	18,200	1969-70	-6530	51,130	115
La Tuna	35	595,914	172,100	1977-78	2515	492,745	99
Las Flores	55	214,754	36,000	1937-38	673	56,927	99
Las Lomas	7	(6)	(6)	(6)	35	9,265	100
Limekiln	27	270,549	42,300	1965-66	9245	162,355	95
Lincoln	55	126,104	28,400	1968-69	1023	37,377	97
Linda Vista	20	11,407	3,400	1977-78	-242	3,442	108
Little Dalton	31	905,170	337,800	1968-69	12037	644,463	98
Maddock	36	56,454	16,200	1980-81	2420	43,480	95
Marston/Paragon	2	(8)	(8)	(8)	0	(8)	(8)
May No. 1	37	203,322	45,800	1968-69	-505	64,505	101
May No. 2	37	27,314	6,200	1966-67	3	9,997	100
Monument	9	2,855	2,600	1981-82	138	6,662	98
Morgan	26	30,292	12,900	1968-69	1079	50,021	98
Mountbatten	7	55	(6)	(6)	55	1,345	96
Mull	17	1,970	1,100	1979-80	62	15,938	100
Mullally (10)	16	51,849 (4)	24,400 (4)	1977-78	596	11,404	95 (14)
Nichols	53	126,652	21,800	1951-52	2020	11,080	85
Oak	15	13,258	6,900	1977-78	739	7,961	92
Oakglade	16	1,455	1,200	1977-78	549	11,751	96
Oakmont View Drive	6	(6)	(6)	(6)	0	3,400	100
Oliver	1	30380 (15)	16255	1977-78	40	32060	100
Pickens	55	716,116	140,600	1977-78	6285	125,115	95
Pinelawn	17	5,113	1,200	1976-77	325	5,475	94
Rowley	37	76,207 (4)	16,700 (4)	1977-78	-1540	39,240	104
Rowley (Upper)	14	49,019 (4)	31,900 (4)	1977-78	384	28,416	99
Rubio	47	271,322	133,000	1979-80	2159	125,041	98
Ruby (Lower)	35	20,448	8,300	1968-69	4696	23,904	84

D E B R I S B A S I N - D E B R I S P R O D U C T I O N H I S T O R Y

Including 1989 - 1990

Compiled by: Hydraulic and Water Conservation
Division - Sedimentation Section

Date: October 1, 1990

FILE: DSB90.WK1

DATA SHEET B

DEBRIS BASIN	NUMBER OF SEASONS	TOTAL DEBRIS DEPOSITED CU. YDS. (1)		MAXIMUM SEASONAL DEBRIS PRODUCTION		ESTIMATED CONDITIONS		
				CU. YDS.	SEASON	DEBRIS STORED CU. YD.	CAPACITY AVAILABLE ----- CU. YD. PER CENT	
Rye	9	10,419		10,000	1981-82	22	19,078	100
Santa Anita	31	689,384 (2,3)		132,000 (2,3)	1961-62	252	393,648	100
Sawpit	36	680,058 (2,3)		233,800 (2,3)	1968-69	402	644,098	100
Scholl	45	16,794		3,500	1968-69	668	10,432	94
Schoolhouse	28	33,550		21,600	1962-63	4295	63,405	94
Schwartz	14	45,183		23,400	1977-78	7360	38,040	84
Shields	53	173,202 (3)		35,100	1937-38	1717	33,083	95
Sierra Madre Dam (12)	63	363,695 (2)		95,200 (2)	1968-69	-1178	134,778	101
Sierra Madre Villa	33	508,701		118,600	1961-62	-38674	441,374	110
Snover	54	104,397		21,100	1938-39	524	22,876	98
Sombrero	21	6,030		3,300	1977-78	168	87,732	100
Spinks	32	67,086		16,400	1968-69	-5374	61,327	110
Starfall	17	27,128		14,200	1977-78	-818	19,218	104
Stetson	21	5,035		1,500	1977-78	0	39,000	100
Stough	50	161,148		44,100	1964-65	9688	171,512	95
Sturtevant	23	1,321		500	1977-78	106	2,194	95
Sullivan	20	89,957		35,300	1979-80	1183	49,817	98
Sunnyside	20	1,749		800	1978-79	-25	4,325	101
Sunset Canyon-Deer	8	3,678		3,200	1982-83	40	6,360	99
Sunset (Lower)	27	142,169		29,200	1980-81	16525	144,075	90
Sunset (Upper)	62	142,392		27,000	1964-65	-1144	17,044	107
Turnbull	38	50,514 (2)		15,900 (2)	1968-69	-850	21,150	104
Upper Shields (10)	14	39,692 (4)		16,900	1977-78	-228	5,828	104
Valley	4	200		(6)	(6)	200	3800	95
Verdugo	55	807,740		105,400	1937-38	8680	122,320	93
Ward	34	51,668		17,800	1977-78	230	12,170	98
West Ravine	55	148,333		29,900	1937-38	9538	37,262	80
Westridge	16	200		(6)	(6)	187	1,213	87
Wildwood	23	67,450		16,700	1977-78	1392	21,108	94
William S. Hart Park	7	1,329		1,000	1983-84	298	2,102	88
Wilson	28	217,968		55,500	1968-69	21571	295,329	93
Winery	22	23,137		9,400	1968-69	1935	27,265	93
Zachau	34	107,185 (4)		48,100 (4)	1977-78	1059	37,541	97

115 DEBRIS BASINS

DEBRIS BASIN - DEBRIS PRODUCTION HISTORY

DATA SHEET B

Including 1989-1990

Compiled by: Hydraulic and Water Conservat
Division - Sedimentation Sect
Date: October 1, 1990

- (1) VOLUME OF DEBRIS DEPOSITED IN BASINS DOES NOT INCLUDE DEBRIS SLUICED THROUGH OPEN PORTS OR NOTCH.
- (2) VOLUME OF DEBRIS DEPOSITED DOES NOT INCLUDE DEBRIS WHICH PASSED OVER SPILLWAY DURING THE STORMS IN 1968-69 SEASON.
- (3) INCLUDING DEBRIS FROM UPSTREAM BASIN OR DAM.
- (4) VOLUME OF DEBRIS DEPOSITED DOES NOT INCLUDE DEBRIS WHICH PASSED OVER SPILLWAY DURING THE STORMS IN 1977-78 SEASON.
- (5) DEBRIS CAPACITY AVAILABLE WITHIN RIGHT OF WAY LIMITS.
- (6) NO SIGNIFICANT DEBRIS INFLOWS RECORDED.
- (7) NO RECORDS OF DEBRIS DEPOSITION EXIST FOR THE FIRST 9 SEASONS.
- (8) INFORMATION UNAVAILABLE.
- (9) MAXIMUM CAPACITY MAY BE MORE THAN SHOWN AND IS BEING REVIEWED.
- (10) SPECIAL CLEANOUT REQUIRED DUE TO LIMITED STORAGE.
- (11) TRANSFERRED FOR MAINTENANCE AFTER 87-88 STORM SEASON. FIRST DEBRIS SEASON WILL BE 88-89.
- (12) CLEANOUT WHEN DEBRIS REACHES OR EXCEEDS ELEV. 1128.9 AGAINST FACE OF DAM.
- (13) VALUES ARE COMBINED WITH COOKS DEBRIS BASIN.
- (14) TO BE CLEANED.
- (15) DATA FROM PREVIOUS BASIN.



PACIFIC OCEAN

ROANUCET FIRE
7-15-90
(TOTAL 600 ACRES)

CARBON FIRE
6-27-90
(IN L.A. COUNTY 900 ACRES)

SCALE
1:25,000

REVISIONS		LOS ANGELES COUNTY DEPARTMENT OF PUBLIC WORKS	
NO.	DATE	BY	DESCRIPTION
1			1989 - 90 BURNED AREA LOCATION MAP
SCALE	DATE	NO.	NO.

WATER QUALITY

WATER QUALITY

Since its conception, the Flood Control District (now Department of Public Works) has actively engaged in operations which have proven indispensable in preserving the integrity of our water resources, both quantity and quality, and has aided in the establishment of regulations or controlling criteria by those agencies so empowered.

Prior to March 1986, monitoring activities in the field of water quality control were conducted by the Water Quality Section of Hydraulic/Water Conservation Division. In March 1986, the responsibilities of conducting such activities were transferred to Waste Management Division as a result of the consolidation. These activities include, among others, the collection of water quality samples, their analyses, and the interpretation and reporting of the resulting data.

Areas of involvement include the monitoring of all groundwater basins through the sampling of numerous wells, the monitoring of storm and low water flows at various strategic locations on the major streams or channels, and an assumed or obligated responsibility to monitor the quality effects and subsurface travel of recharge areas, specifically the Whittier Narrows Spreading Grounds area.

The Water Quality Section, together with personnel of other Departmental divisions, also conducts investigations into pollution problems relative to our facilities, particularly those from industrial discharges, vehicle accidents, ruptured pipelines, or the indiscriminate dumping of various waste products.

The principal objectives of these investigations are to determine the degree and apparent source or origin of the pollution and to take the necessary action that will immediately abate the existing problem and possibly provide a means to prevent or limit recurrence.

The above-mentioned activities of the Water Quality Section have recently been intensified, particularly in the areas of interfacing coordinating with other municipalities/cities, environmental organizations, as well as Federal and State agencies, in an effort to comply with the regulations and requirements mandated under the 1987 Clean Water Act, whereby the Department's storm drain system is under the National Pollutant Discharge Elimination System (NPDES) permitting regulations of the California Regional Water Quality Control Board (CRWQCB).

Under the provisions of the NPDES permit issued to Los Angeles County by the CRWQCB on June 18, 1990, the Department is required to establish a work plan for the development of a comprehensive monitoring program in accordance with a three-phase schedule, for the County, as outlined in the NPDES permit (CA0061654).

The first phase of the work plan which involves Santa Monica Bay drainage basin is expected to be completed and implemented by the middle of 1993.

SURFACE WATER QUALITY

Prior to 1984, dry weather samples were collected from 30 sampling stations on a monthly basis for analysis such as general minerals, bacteria, pesticides, and heavy metals. In addition, storm samples were also collected and analyzed at least three times annually from the same 30 stations during storm season.

From 1984 to 1987, as a result of reorganization, the number of surface water monitoring stations was reduced to 21, while the parameters analyzed were reduced to include only total dissolved solids, pH, and dissolved oxygen. Storm sampling activities were also significantly curtailed.

In 1988, recognizing the inadequacy of the then existing monitoring program to meet the Department's need in dealing with all the important issues in the areas of water quality, the Department Administration approved and implemented an expanded monitoring program effective May 1, 1988.

There are 28 monitoring stations in the Department's current Surface Water Quality Monitoring Program, from which dry weather samples are collected and analyzed on a monthly basis. These sampling stations are strategically located throughout the Department's major storm drains and water conservation facilities where the flows are representative of typical land uses as well as areas of significant water quality concerns. Of the 28 monitoring stations in the program, six are located at the outlets to Santa Monica Bay, while one is located in the mountain area where the flow is considered to be natural and uncontaminated with the various pollutants associated with urbanization and developed land uses.

Monthly dry weather samples, thus collected, are analyzed for general minerals, (pH, specific conductance, total dissolved solids, total hardness, potassium sulfate, calcium, magnesium, chloride, fluoride, nitrate-nitrogen, nitrite- nitrogen, ammonium-nitrogen, phosphate-P, boron, iron, and manganese) bacteria, pesticides, heavy metals (silver arsenic, barium, cadmium, chromium, mercury, lead, selenium, copper, nickel, zinc, and chromium [VI]), oil and grease, total organic carbon, total petroleum hydrocarbons, PCB's, biochemical oxygen demand, and volatile organic compounds (TCE, carbon tetrachloride, vinyl chloride, 1,2 dichlorethene, benzene, 1,1 dichloroethylene, 1,1,1 trichloroethane, p-dichlo robenzene). In addition, storm samples are collected for three to four storms annually from 21 stations, including San Gabriel Coastal and Rio Hondo Spreading Grounds for extensive analysis similar to those for dry weather samples, with additional testing of total suspended solids and volatile suspended solids to be included. For storm samples collected at San Gabriel Coastal and Rio Hondo Spreading Grounds, priority pollutant constituents are also analyzed under an agreement with the Central and West Basin Water Replenishment District.

A selective list of total dissolved solids is shown for some of the sampling locations on the streams and channels monitored under the Surface Water Quality Program. For a conception of the analysis performed on surface flows, a yearly compilation of constituent determination is shown for one (Los Angeles River at Wardlow) of the sampling stations in the program.

GROUNDWATER QUALITY

The annual sampling of water wells, under a selected scheduling, in five major basins in Los Angeles County comprise the Groundwater Quality Program. The program, initiated in 1970, is coordinated with the State of California Department of Water Resources and the City of Los Angeles Department of Water and Power. These agencies participate in the obtainment and analysis of samples.

All the water wells samples are active production wells used either for municipal supply, irrigation, or for industrial purposes and are selected to represent a general portrayal of basin water quality conditions. The samples taken under this program are analyzed for major mineral, total dissolved solids, electrical conductivity, pH, and in specific cases, phosphate, iron, manganese, fluoride, or boron.

WATER QUALITY DATA ACCESSIBILITY

Data acquired from the various programs are on file in the Water Quality Section. In addition, all data is accessible to any user through STORET, an Environmental Protection Agency computer system that stores, retrieves, and manipulates data using agency code 21CALAFD.

Surface Water Quality Monitoring Selected Surface Station

Table 1 Total Dissolved Solids - mg/l
1989-90 Season (Dry Weather Flow)

FS

Sampling Location	Oct. 1989	Nov. 1989	Dec. 1989	Jan. 1990	Feb. 1990	Mar. 1990	Apr. 1990	May 1990	Jun. 1990	Jul. 1990	Aug. 1990	Sep. 1990	Average Value
Ballona Creek at Sawtelle Blvd.	768	726	661	683	704	704	711	724	599	757	647	668	696
Coyote Creek at Orangethorpe Avenue	956	953	498	876	801	855	853	906	820	925	967	934	862
Willow Street	714	657	586	737	1060	683	710	679	688	831	655	880	740
Dominguez Channel Above Vermont Avenue	2693*	2177*	509	2338*	646	692	415	742	566	632	625	568	450
Los Angeles River at Wardlow Road	689	669	640	625	560	631	669	618	586	733	754	631	650
Firestone Boulevard	686	647	604	633	645	643	645	631	666	667	700	668	653
Los Cerritos Channel at Stearns Street	543	492	383	469	479	436	523	669	648	841	865	641	582
Rio Hondo River at Southern Avenue	634	533	519	593	350	696	984	945	533	748	802	762	675
Spreading Grounds	**	431	589	665	418	511	483	595	614	614	576	539	503
Santa Monica Cyn. Ch. at Short Street	1004	910	914	910	696	998	1048	925	875	941	926	910	921
San Gabriel River at Spreading Grounds	379	441	634	676	492	485	499	**	636	**	628	604	456
Willow Street	831	852	753	858	714	677	753	578	834	815	720	883	772
San Jose Creek at Workman Mill Road	923	865	848	646	632	654	638	831	671	825	657	643	736

* Influenced by tidal water; not included in average

** No samples collected due to dry conditions

Water Quality Analysis (Partial Data)

Monthly Monitoring 1989-90 Season (Dry Weather)

Los Angeles River @ Wardlow Road

Constituent mg/l	Oct. 1989	Nov. 1989	Dec. 1989	Jan. 1990	Feb. 1990	Mar. 1990	Apr. 1990	May 1990	Jun. 1990	Jul. 1990	Aug. 1990	Sep. 1990	Average
Hardness as CaCO3	275	285	264	219	215	221	283	224	193	281	289	229	248
Calcium	63	70	64	49	51	53	68	56	41	62	60	69	59
Magnesium	28	27	25	24	21	22	28	21	22	31	34	14	25
Sodium	118	104	109	119	94	121	131	135	109	143	135	106	119
Potassium	13.3	10.8	11.4	10.7	10.5	10.1	11.2	8.9	8.9	9.2	9.5	11.5	10.5
Ammonium-N	0.40	0.20	2.90	4.90	3.60	0.61	1.70	0.27	0.28	1.56	0.20	2.13	1.56
Alkalinity as CaCO3	150	153	165	150	134	115	157	116	137	177	188	76	143
Sulfate	168	164	149	146	128	155	171	154	120	178	173	175	157
Chloride	138	123	118	123	105	133	158	164	132	152	142	170	138
Nitrate-N	5.88	8.93	4.05	3.23	5.42	4.52	1.51	1.70	0.40	2.13	8.08	1.10	3.91
Phosphate	1.5	2.2	0.4	2.9	0.7	1.6	1.7	0.4	0.6	1.6	1.1	0.4	1.2
Total Dissolved Solids	689	669	640	625	560	631	669	618	586	733	754	631	650
BOD	4.0	2.0	3.0	5.0	3.0	3.0	5.0	5.0	3.0	5.5	6.4	5.4	4.2
Total Organic Carbon	13.2	8.1	<1	16.2	10.7	6.3	11.2	18.2	21.0	9.0	16.3	11.0	12.8
MPN/100ml													
Fecal Coliform	79	330	490	17000	23000	79	790	NA	49000	790	300	<2	8350
Total Coliform	11000	2200	13000	79000	23000	2200	1300	NA	330000	3300	1300	<2	42400
Fecal Streptococcus	230	330	2300	790	7900	290	170	NA	14000	330	170	110	2400
Enterococcus	130	330	2300	790	4900	330	170	NA	11000	170	170	110	1850
pH	9.0	8.9	8.6	8.4	7.8	9.3	8.2	9.6	7.6	7.9	8.8	10.2	8.7
Temperature (F)	69	66	49	58	44	64	70	76	76	80	70	80	67

NA = Not Analyzed

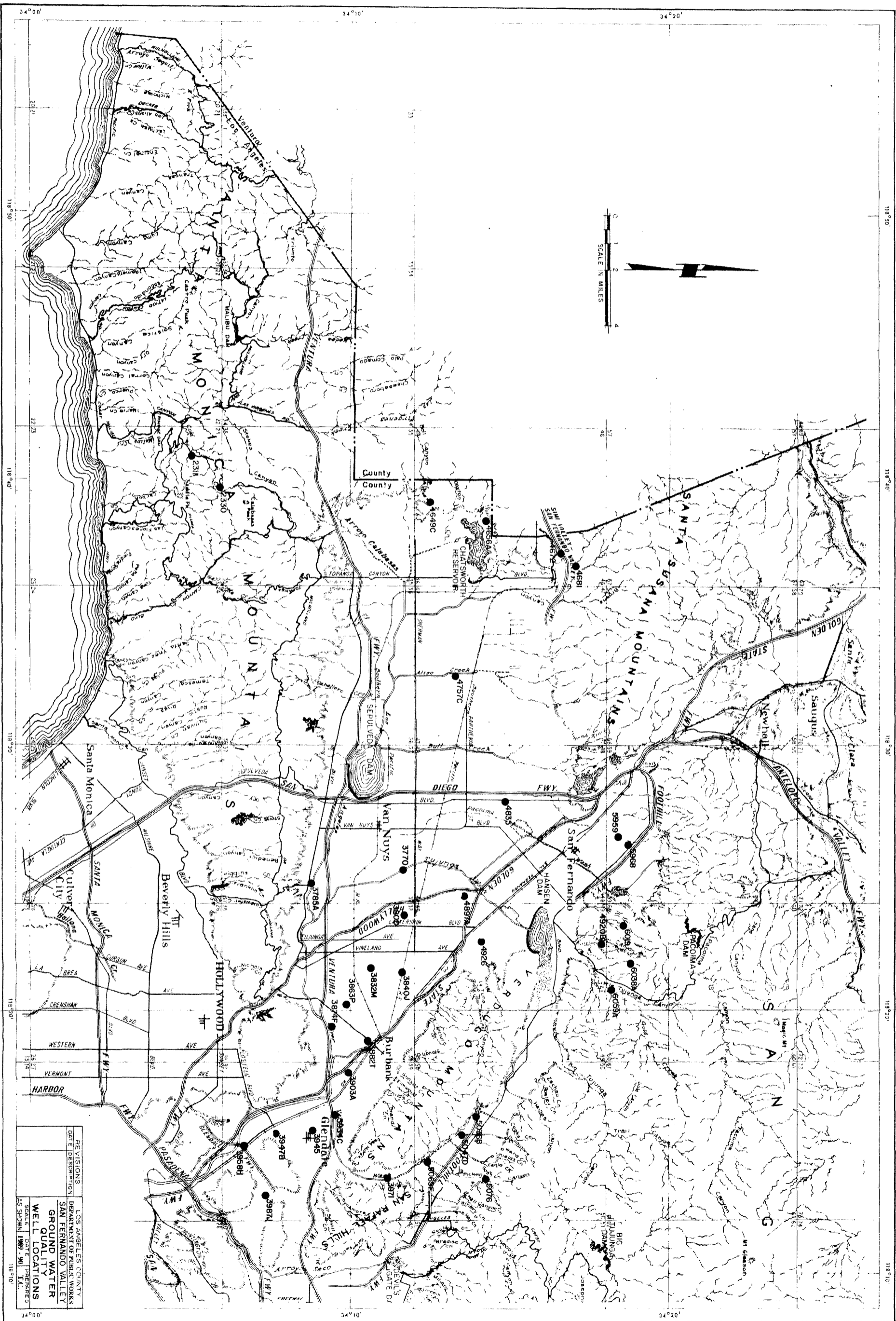

REVISIONS	DATE	DESCRIPTION
LOS ANGELES COUNTY DEPARTMENT OF PUBLIC WORKS SAN FERNANDO VALLEY GROUND WATER QUALITY WELL LOCATIONS		
SCALE	1 INCH = 1 MILE	
AS SHOWN	1967-90	
		18-10

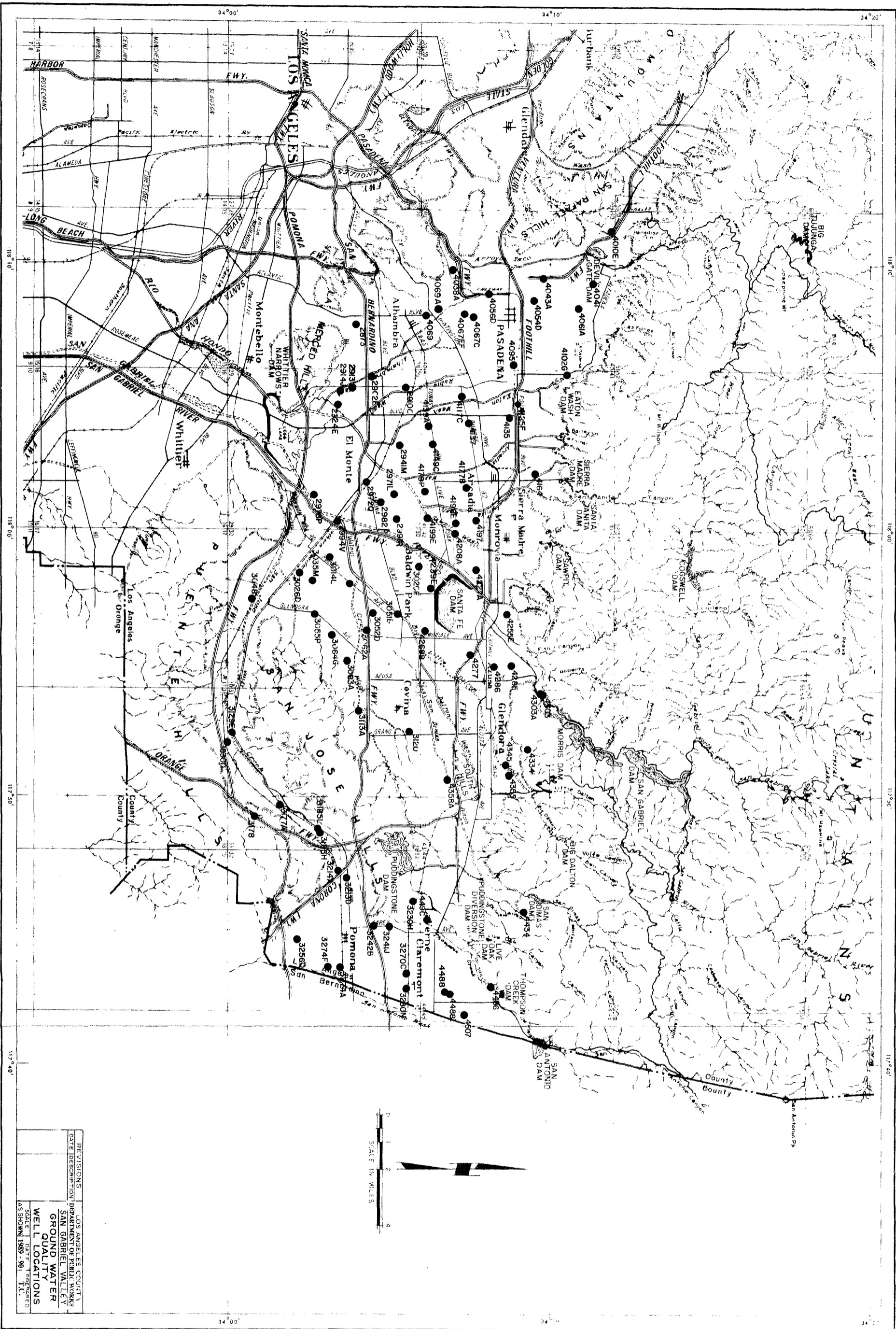

REVISIONS	DATE	DESCRIPTION
1		PRELIMINARY
2		FINAL

LOS ANGELES COUNTY
 DEPARTMENT OF PUBLIC WORKS
 SAN GABRIEL VALLEY
 GROUND WATER
 QUALITY
 WELL LOCATIONS

SCALE: 1" = 1 MILE
 DATE: 1989
 AS SHOWN 1989 - 90
 T.C.

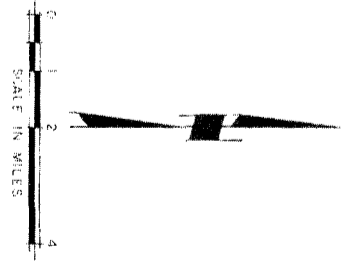

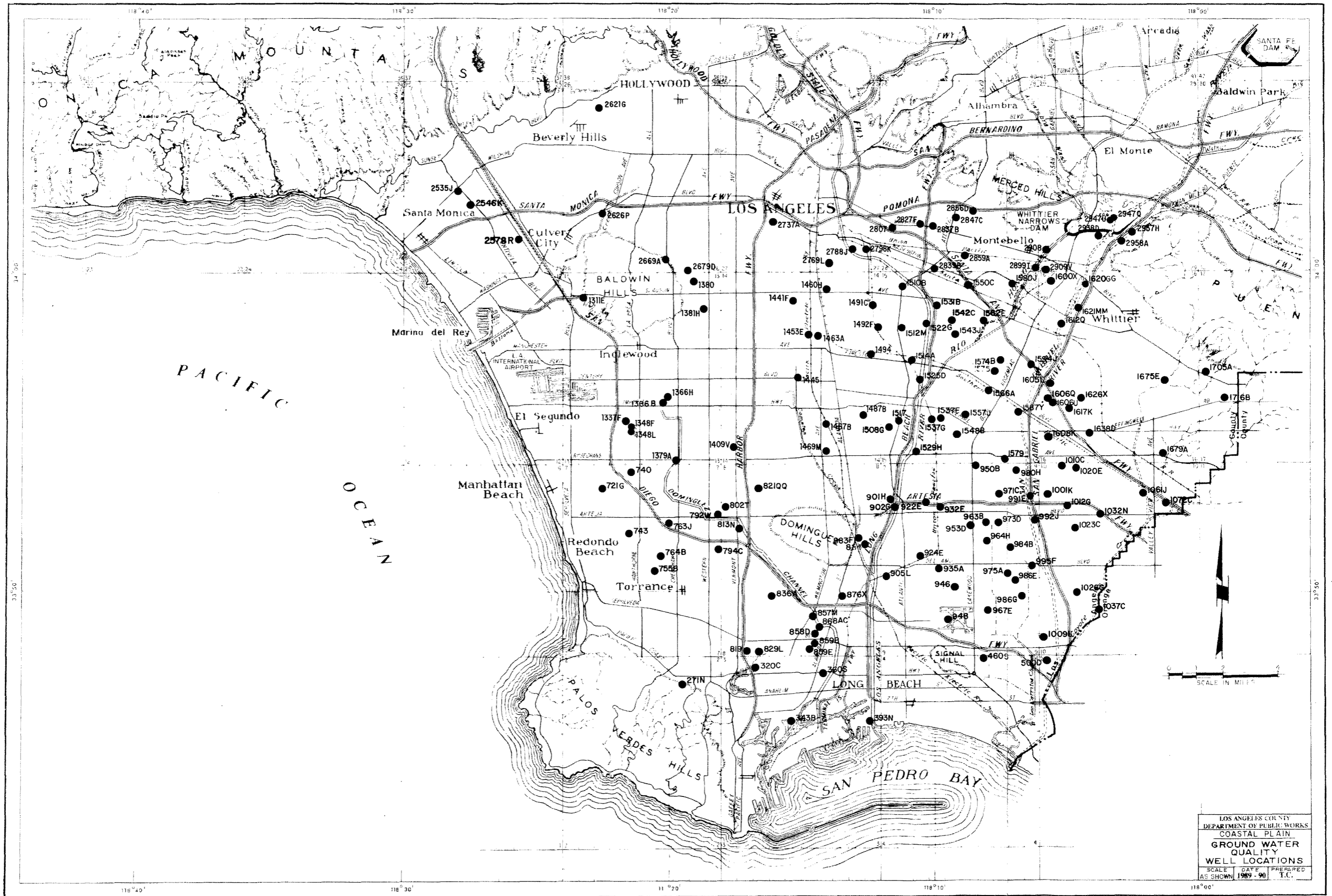

LOS ANGELES COUNTY
 DEPARTMENT OF PUBLIC WORKS
 COASTAL PLAIN
 GROUND WATER
 QUALITY
 WELL LOCATIONS
 SCALE DATE PREPARED
 AS SHOWN 1989-90 T.C.

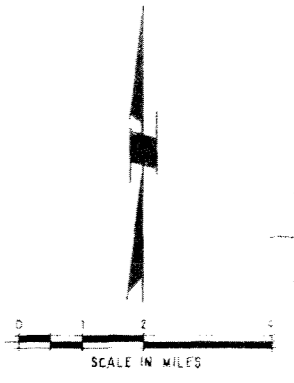
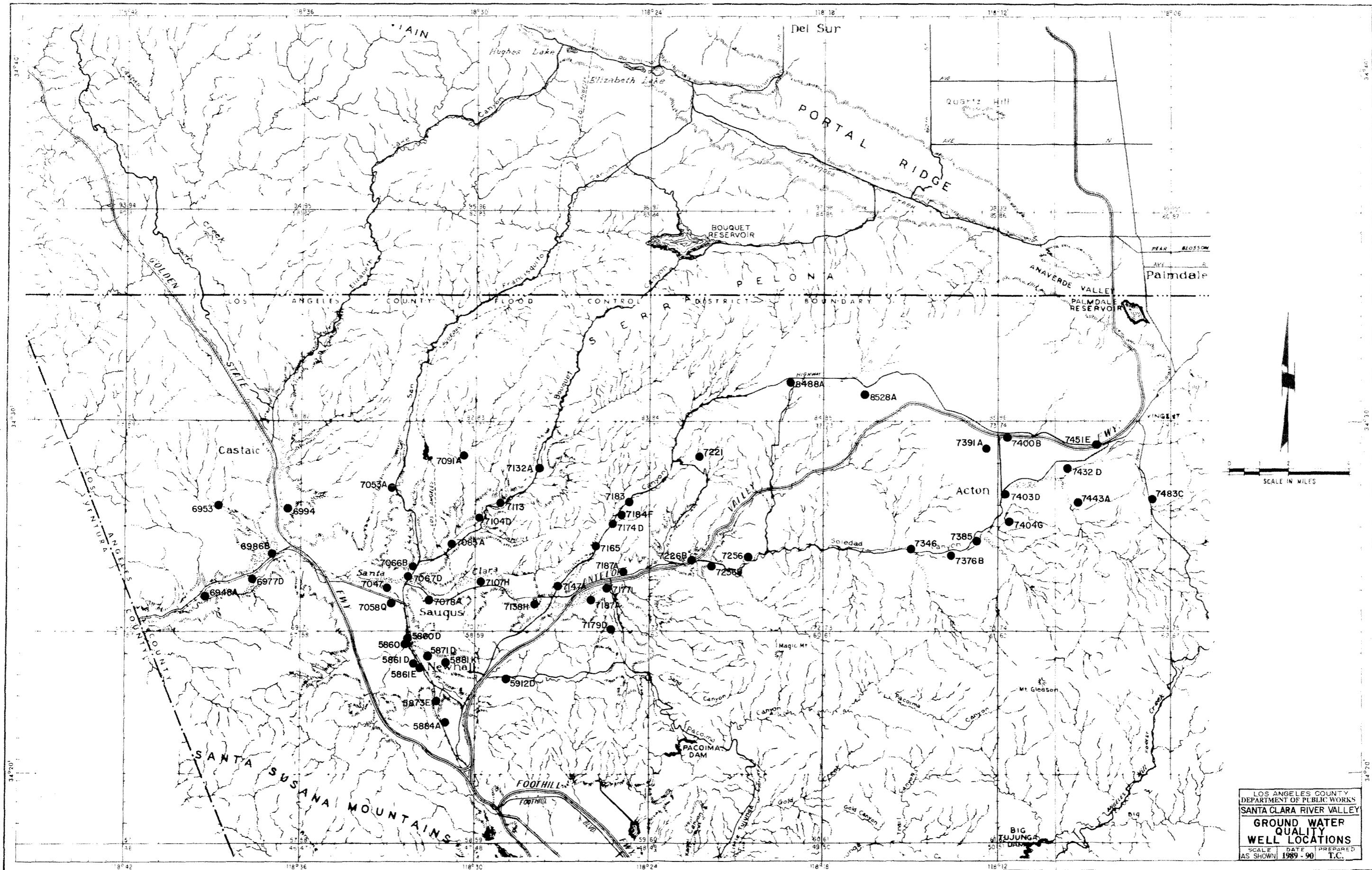

LOS ANGELES COUNTY
 DEPARTMENT OF PUBLIC WORKS
 SANTA CLARA RIVER VALLEY
 GROUND WATER
 QUALITY
 WELL LOCATIONS
 SCALE: AS SHOWN DATE: 1989-90 PREPARED BY: T.C.

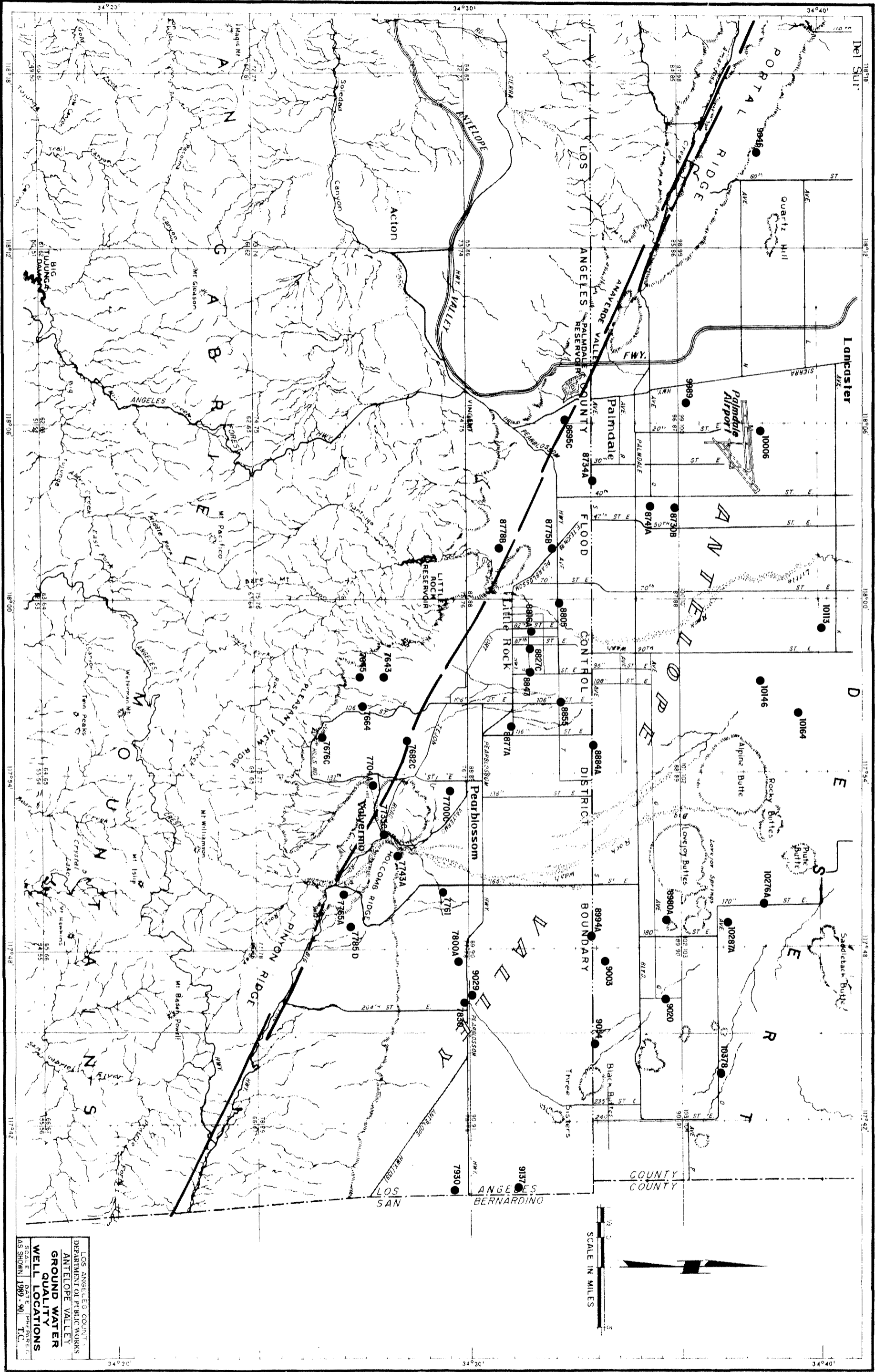

LOS ANGELES COUNTY
 DEPARTMENT OF PUBLIC WORKS
 ANTELOPE VALLEY
 GROUND WATER
 QUALITY
 WELL LOCATIONS
 SCALE 1:50,000
 DATE 1989
 SHEET 101

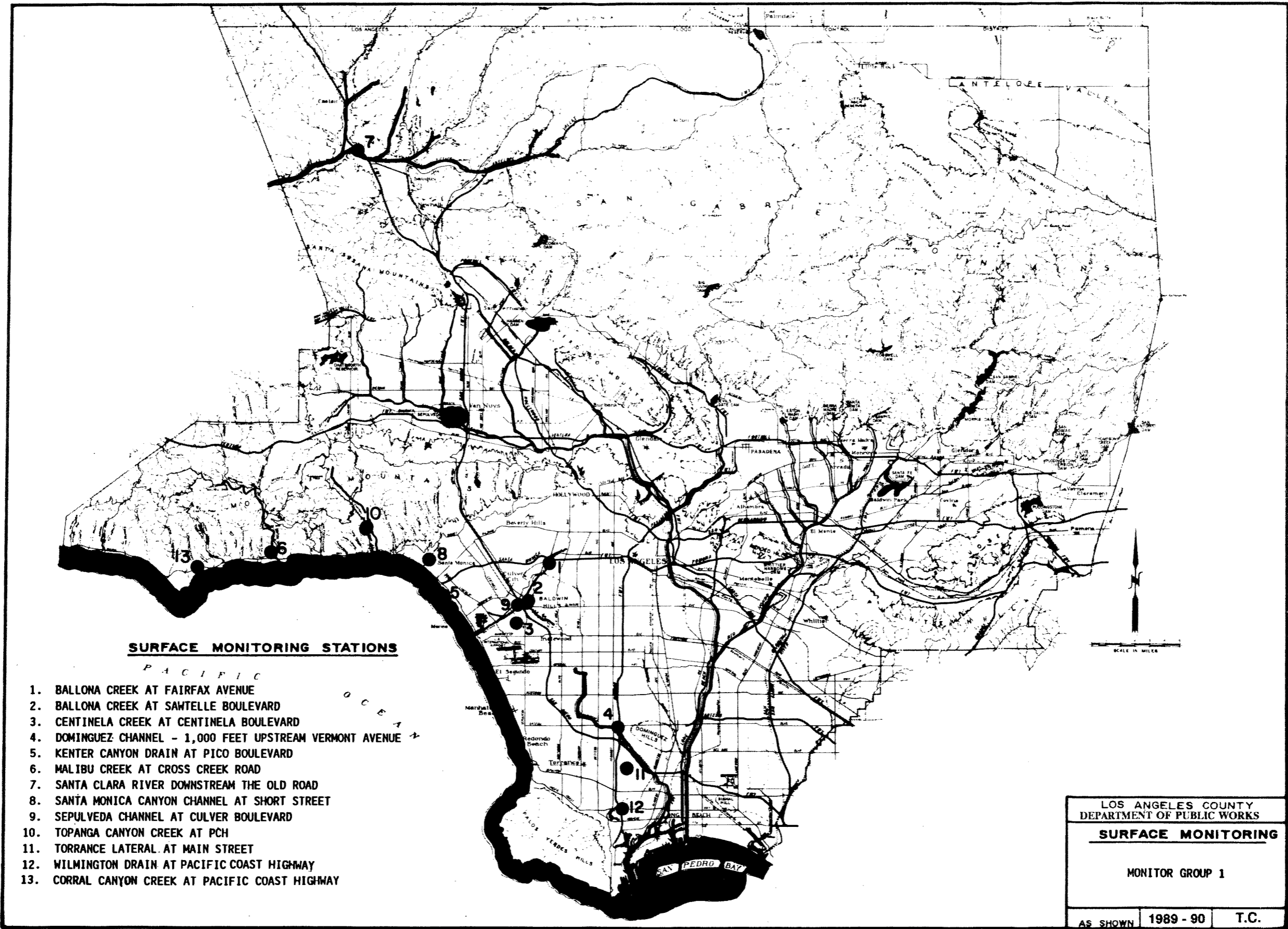

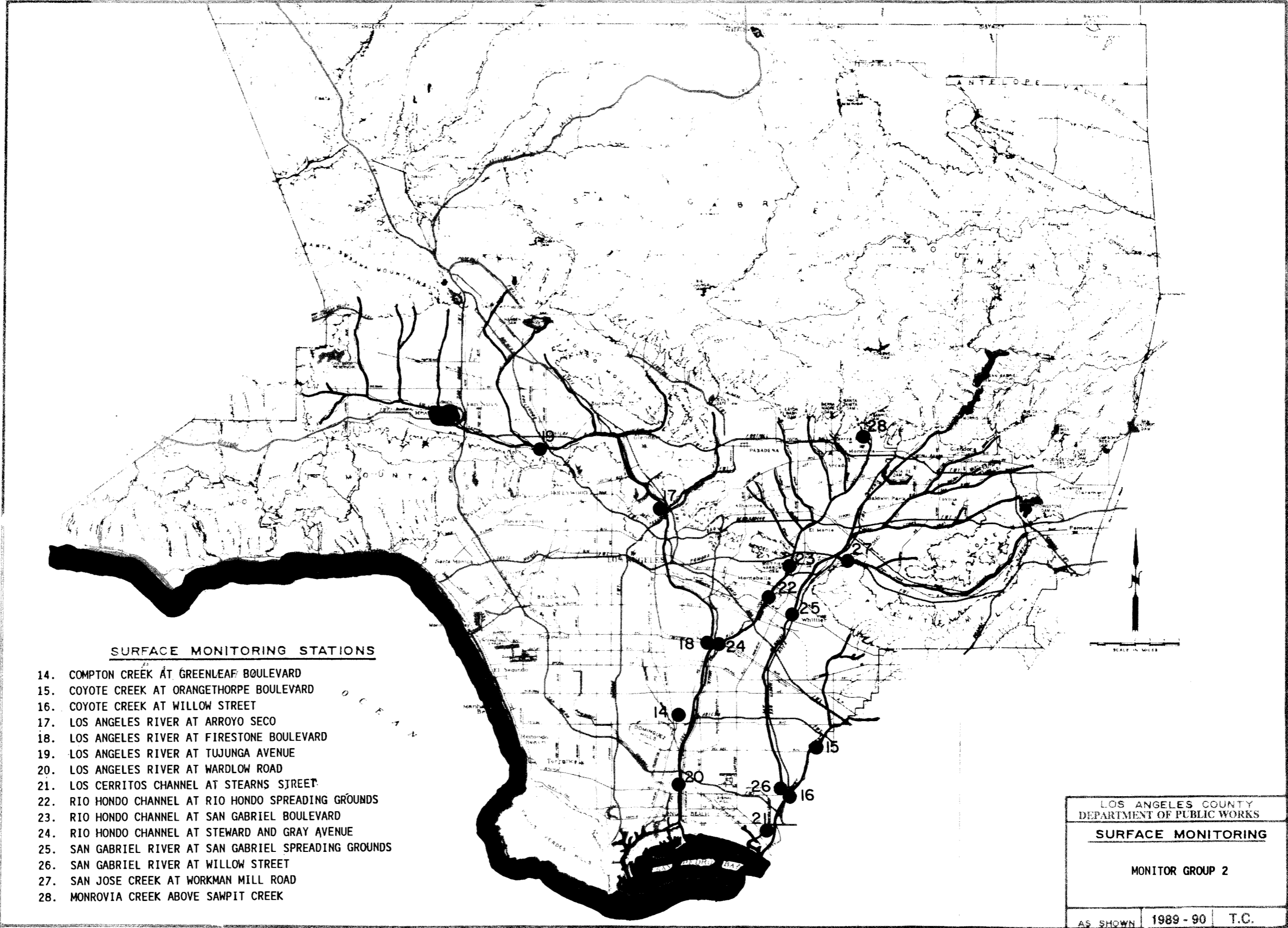

WATER CONSERVATION

WATER CONSERVATION

Information presented in this section includes amounts of local, imported, and reclaimed water conserved in spreading areas and information on the seawater barrier projects which prevent saltwater intrusion to groundwater zones in the coastal areas. Pertinent data is presented regarding the locations and descriptions of Department water conservation facilities, as well as facilities owned by others. Also included are groundwater maps delineating static groundwater elevations recorded during the report period and hydrographs of selected key wells.

CONSERVING THE WATERS

In addition to its flood control program, the Department has the equally important task of conserving as much of the storm and other waters as practicable. The use of water conservation facilities adjacent to river channels, and in soft-bottom channels permits water to percolate into groundwater basins for later pumping. These water spreading facilities are located in areas where the underlying soils are composed of pervious formations.

The various types of water conserved, local, imported, and reclaimed, are construed to have the following meanings in this section: Local water is primarily runoff due to rainfall on the mountain and valley watersheds, dam releases, and rising water within the County. Imported water is water originating outside the County either from Northern California or from the Colorado River, commonly blended from both sources which is transported to and delivered within the County. Reclaimed water is the effluent produced by the Whittier Narrows Water Reclamation Plant, the San Jose Creek Water Reclamation Plant, and the Pomona Reclamation Plant, all operated by the Los Angeles County Sanitation District.

The importance of this activity is apparent when it is realized that about 35 to 45 percent of the water used in the County is pumped from ground supplies. The growth of the County, combined with periodic droughts, has seriously depleted these supplies on numerous occasions.

The Department's policy is to conserve the maximum amount of storm water possible consistent with considering runoff quantity and quality, capacities of the spreading facilities, and groundwater conditions.

IMPORTED WATER

During this report period, imported Colorado River and State Project water for spreading was obtained from the Metropolitan Water District. Imported water for groundwater recharge in the Coastal Plain was spread at the Department's facilities in the Rio Hondo and San Gabriel Coastal Basin Spreading Grounds and in the San Gabriel River systems, south of Whittier Narrows Dam, on behalf of the Central and West Basin Water Replenishment District. Imported water for groundwater recharge in the San Gabriel Valley was spread in Santa Fe Spreading Grounds, in the San Gabriel River between Morris and Santa Fe Dams, in Irwindale Spreading Basin and in Forbes Spreading Grounds on behalf of MWD, the Main San Gabriel Basin Watermaster, and the San Gabriel Valley Municipal Water District.

RECLAIMED WATER

The County Sanitation Districts' Whittier Narrows Water Reclamation Plant effluent, purchased by the Central and West Basin Water Replenishment District, was transported to the Rio Hondo and San Gabriel Coastal Basin Spreading Grounds and San Gabriel River System for groundwater replenishment.

The County Sanitation Districts' San Jose Creek Water Reclamation Plant, activated in May 1972, made its first delivery of effluent in November 1972. The portion of the effluent that is spread is also purchased by the Central and West Basin Water Replenishment District.

The maximum amount of reclaimed water allowed for spreading annually in the Montebello Forebay is 50,000 acre-feet effective July 1989.

SEAWATER BARRIER PROJECTS

The Department operates three barrier projects to protect the groundwater in the West Coast and Central Basins against seawater intrusion by creating freshwater pressure ridges along the coastline. The pressure ridges are created by injecting fresh water through a series of injection wells. During the report period, 20,279 acre-feet of water was injected at the West Coast Basin Barrier Project, 5,736 acre-feet at the Dominguez Gap Barrier Project, and 4,112 acre-feet at the Los Angeles part of the Alamitos Barrier Project. On behalf of the Orange County Water District, 1,929 acre-feet of water was injected at the Orange County portion of the Alamitos Barrier Project.

The following construction projects were performed on the barriers during the report period:

1. Alamitos Barrier Project:

Two single zone injection wells, two single zone observation wells, and cluster wells at five sites were constructed.

2. Dominguez Gap Barrier Project

One single zone injection well and seven multi-zone observation wells were constructed.

3. West Coast Basin Barrier Project

A contract for five single zone injection wells was awarded.

SEASONAL DATA AND MAPS

During this report period, monthly and semi-annual measurements of groundwater levels in observation wells located throughout the groundwater basins in Los Angeles County were made and processed.

Hydrographs of selected key wells are included in this report.

GROUNDWATER BASINS AND GROUNDWATER RECHARGE

Groundwater in Los Angeles County is stored in basins underlying five major geographic areas. These groundwater basins are separated by geologic features which impede groundwater movement or sometimes by arbitrary political boundaries. The following is a background and summary of the Department's groundwater recharge activities within each of these areas:

The Department operates 2,369 acres of spreading grounds and basins and soft-bottom channel spreading areas for replenishment of local aquifers to increase water supplies. The Department also assisted in the operation and maintenance of 679 acres of spreading grounds owned by others. An additional 246 acres of spreading grounds are controlled, maintained, and operated by other agencies. The total gross acreage of spreading grounds in the County is 3,294 acres. During the report period, the Department conserved approximately 54,543 acre-feet of storm runoff.

The conservation of local runoff is supplemented by spreading imported water and reclaimed water purchased by water agencies. During the period, 130,382 acre-feet of imported water and 50,107 acre-feet of reclaimed water were spread.

The Department is continuing its efforts to improve its water spreading facilities in order to maximize the amounts of water conserved and to simplify the spreading operations.

SAN GABRIEL VALLEY

The Department operates 20 spreading grounds in the San Gabriel Valley that receive direct valley runoff and flows from the San Gabriel Mountains. Some of these spreading grounds can also receive imported water. During the report period, the Department added approximately 31,633 acre-feet of local water and 70,651 acre-feet of imported water to the groundwater stored in the basins underlying the San Gabriel Valley and diverted 2,832 acre-feet of local water to grounds owned by others.

The following construction projects were performed in San Gabriel Valley during the report period:

1. Citrus Spreading Grounds

Construction of the "Granado Drain" to direct excess Covina Irrigation Company water to Big Dalton Wash for spreading in Citrus spreading Grounds was completed.

2. Eaton Spreading Basin and Eaton Wash Spreading Grounds:

Existing intake gates at both facilities were fitted with electric motor operators.

3. Irwindale Spreading Basin:

A contract for constructing the inlet structure to Manning Pit was awarded.

Main San Gabriel Basin

This is the largest basin underlying the San Gabriel Valley with an estimated storage capacity of 9.5 million acre-feet. It reacts quickly to artificial spreading in Santa Fe Reservoir Spreading Grounds and to infiltration in the San Gabriel River downstream of Santa Fe Dam.

During the report period, the Department replenished the Main San Gabriel Basin with 27,829 acre-feet of local water and 34,326 acre-feet of imported water. Also, a new historic low for the groundwater elevation in the San Gabriel Main Basin was recorded. At well 3030F in Baldwin Park, the lowest elevation was 199.2 feet on September 11, 1990.

Upper San Gabriel Canyon Basin

Approximately 2,869 acre-feet of local water and approximately 34,934 acre-feet of imported water were recharged by the Department through its San Gabriel Canyon Spreading Grounds and by percolation in the adjacent San Gabriel River. Also, 2,193 acre-feet of local water was routed to Fish Canyon Spreading Grounds which is operated by the Committee of Nine.

Lower San Gabriel Canyon Basin

The basin is located south of the Upper San Gabriel Canyon Basin and is separated from it by the underground Lohmon Dike. Groundwater cascades over the Lohmon Dike from the Upper San Gabriel Canyon Basin and recharges the Lower San Gabriel Canyon Basin. The Department spread 367 acre-feet of local water in Sawpit Spreading Grounds which is within the Lower Canyon Basin.

Wayhill Basin

The Department spread 210 acre-feet of local water and 1,391 acre-feet of imported water at its Forbes spreading facility in the Wayhill Basin.

Foothill Basin

The Department spread 127 acre-feet of local water at its San Dimas Canyon Spreading Grounds facility in the Foothill Basin.

Glendora Basin

The Department spread 11 acre-feet of local water in its Dalton facilities within the Glendora Basin.

Claremont Heights Basin

Approximately 5 acre-feet of local water were diverted to the Pomona Valley Protective Association's Thompson Creek Spreading Grounds which benefits the groundwater in the Claremont Heights Basin.

Live Oak Basin

The Department has no spreading facilities in the Live Oak Basin.

Chino Basin

The basin is located in the most eastern part of the County. No Department recharge facilities are located within the Chino Basin.

San Dimas Basin

The basin is north of the San Jose Hills, east of the Main Basin, and south of the Wayhill Basin. The Department spread 4 acre-feet of local water in its Live Oak Spreading Grounds to recharge the basin.

Pomona Basin

The basin is located south of Claremont, Live Oak, and San Dimas Basins, and north of the Chino Basin and northeast of the San Jose Hills. The Department has no water spreading facilities within this basin.

Puente, Sapdra, and Walnut Basins

No spreading occurs in this area.

Raymond Basin

The basin covering approximately 40 square miles is located in the northwest corner of the San Gabriel Valley and is separated from the Main San Gabriel Basin by the Raymond Fault. The Raymond Basin contains the Monk Hill Basin and the Pasadena and Santa Anita Subareas. The Department recharged 216 acre-feet of local water by its spreading facilities in the Raymond Basin and diverted 634 acre-feet to the City of Sierra Madre's spreading facility during the report period.

COASTAL PLAIN

The groundwater basins underlying the Coastal Plain are divided by geological features into the Central (includes the Montebello and Los Angeles Forebays), West Coast, Santa Monica, and Hollywood Basins. During the period October 1, 1989 to September 30, 1990, the Department recharged 16,266 acre-feet of local water, 59,353 acre-feet of imported water, 50,107 acre-feet of reclaimed water to the groundwater basins underlying the Coastal Plain. Most of the water was spread in the Montebello Forebay.

During the report period, the first phase of the Groundwater Recharge Telemetry System (GRTS I) was being installed. GRTS I provides remote monitoring and control capabilities at Rio Hondo and San Gabriel Coastal Basin Spreading Grounds Headworks. Operator stations are located at Rio Hondo Headworks and at our Fremont Headquarters Operations Center. The next phase (GRTS II) will provide additional remote monitoring and control

points at interbasin structures within Rio Hondo and San Gabriel Spreading Grounds and also at our five rubber dams in the San Gabriel River.

Central Basin

The Central Basin has the most storage capacity of the basins in the Coastal Plain. In addition to the water recharged in the Department's spreading facilities, water injected in the Alamitos Barrier Project also contributes to the replenishment of the pressure aquifers underlying the Central Basin.

Rio Hondo System

One contract for interbasin structure modification and additional earthwork on the east side of the Rio Hondo Coastal Basin Spreading Grounds was completed while a second contract for similar work on the west side was awarded but not completed.

San Gabriel System

A. San Gabriel Coastal Basin Spreading Grounds

Contract work progressing on interbasin structure modification and additional earthwork.

B. San Gabriel River

Extension of the storm drain (Choiser Drain) was constructed to provide an outlet downstream of the rubber dam in the San Gabriel River at Washington Boulevard to prevent backflow in the drain due to potentially high water levels in back of the dam.

West Coast Basin

The West Coast Basin is the second largest basin underlying the Coastal Plain and is separated from the Central Basin by the Newport-Inglewood Fault zone. Groundwater is primarily recharged by Central Basin subsurface flows and by water injected by the Department in the West Coast Basin and Dominguez Gap Barrier Projects. Groundwater elevations in the West Coast Basin are below sea level except in the area of the West Coast Basin Barrier injection mound.

Dominguez Spreading Grounds

The Department spread 43 acre-feet of water in the Dominguez Spreading Grounds.

SAN FERNANDO VALLEY

The San Fernando Valley is also called the Upper Los Angeles River Area (ULARA). Most of the runoff from the surrounding mountains flows to the Valley.

San Fernando Main Basin

The basin is the largest basin underlying the San Fernando Valley. During the report period, 3,789 acre-feet of local water and 378 acre-feet of imported water were spread by the Department. The County entered into an agreement with the City of Los Angeles to spread water at the newly renovated Tujunga Wash Spreading Grounds which is located approximately two miles downstream of Hansen Spreading Grounds. The City installed a rubber dam diversion and appurtenant facilities for County spreading operations which started in March 1990.

Sylmar Basin

A much smaller basin underlying the San Fernando Valley is the Sylmar Basin; the Department has no spreading facility within this basin.

Verdugo and Eagle Rock Basins

The small Verdugo and Eagle Rock Basins comprise the remaining basins underlying the San Fernando Valley. The Department has no spreading facilities within either basin.

SANTA CLARITA VALLEY

The Department has no spreading facilities in the area. Most of the Valley area is farmland, permitting substantial natural percolation.

The Upper Santa Clarita subunit comprises five basins.

ANTELOPE VALLEY

There are several groundwater basins underlying the Antelope Valley, five of them are located within Los Angeles County.

During this report period, the Department recharged over 23 acre-feet of local water in its spreading facility in the Big Rock area to groundwater in the Pearland Basin.

The groundwater level in the Lancaster Basin, has declined steadily since 1925 and reached a new historic low during the report period.

LOS ANGELES COUNTY DEPARTMENT OF PUBLIC WORKS
WATER CONSERVATION DIVISION

SUMMARY OF DATA ON SPREADING FACILITIES
OWNED AND OPERATED BY THE DEPARTMENT
UPDATED THROUGH SEPTEMBER 1990

SPREADING FACILITY	TYPE	SEASON FIRST USED	AREA IN ACRES		CAPACITIES				LOCATION	SOURCE OF WATER	REMARKS
			GROSS	NETTED	CHANNEL**	INTAKE	STORAGE	PERCOLATION*			
					CFS	CFS	A-F.	CFS			
ARROYO SECO	SHALLOW BASINS	1948-49	24	15	-	75	30	18	EASTERLY SIDE OF ARROYO SECO, 0.5 MILES ABOVE DEVIL'S GATE DAM.	CONTROLLED FLOW FROM CITY OF PASADENA. UNCONTROLLED FLOW FROM ARROYO SECO AND THE ALTADENA STORM DRAIN.	SPREADING GROUNDS ARE HELD UNDER EASEMENT FROM THE CITY OF PASADENA.
BEA LOWORD	SHALLOW BASINS	1958-59	24	17	-	25	25	18	BOTH NORTH AND SOUTH SIDES OF SAN DIMAS WASH CHANNEL AT SOUTHWESTERLY CORNER OF INTERSECTION OF ARROW HIGHWAY AND BARRANCA AVENUE.	COVINA IRRIGATING COMPANY.	SPREADING GROUNDS UTILIZED TO CONSERVE EXCESS COVINA IRRIGATION COMPANY WATER RELEASED FROM THE COMMITTEE OF MINE.
BIG DALTON	SHALLOW BASINS	1930-31	24	6	-	25	12	15	WESTERLY SIDE OF BIG DALTON WASH, ONE HALF MILE ABOVE SIERRA MADRE AVENUE.	CONTROLLED FLOWS FROM BIG DALTON DAM AND BIG DALTON DERRIS BASIN.	
BRANFORD	DEEP BASIN	1956-57	12	8	1,540	1,540	137	1	SOUTHWESTERLY OF ARLETA AVENUE ABOVE CONFLUENCE OF TUJUNGA WASH AND PACOIMA DIVERSION CHANNEL.	UNCONTROLLED FLOWS FROM BRANFORD STREET DRAIN.	INSTREAM SPREADING FACILITY. OUTLET CAPACITY 1,540 CFS TO PACOIMA DIVERSION CHANNEL.
BURBA VISTA	DEEP BASIN	1954-55	10	6	2,900	2,900	177	6	1.0 MILE EASTERLY OF SAWPIT WASH. 0.5 MILE NORTHERLY OF ARROW HIGHWAY, BETWEEN MERIDIAN STREET AND BURBA VISTA CHANNEL.	CONTROLLED FLOW FROM SANTA FE DAM AND UNCONTROLLED FLOW FROM BURBA VISTA CHANNEL.	INSTREAM SPREADING FACILITY. AN ADDITIONAL OUTLET CONSTRUCTED TO PROVIDE TOTAL OUTLET CAPACITY OF 270 CFS.
CITRUS	MEDIUM DEPTH BASINS	1960-61	19	14.4	-	250	80	28	SOUTH SIDE OF BIG DALTON WASH BETWEEN CITRUS AND CERRITOS AVENUES.	CONTROLLED FLOWS FROM BIG DALTON DAM AND BIG DALTON, LITTLE DALTON DERRIS BASINS. UNCONTROLLED FLOWS FROM BIG DALTON WASH.	THERE ARE 2 INTAKES, ONE IS A DROP INLET, THE OTHER AN AIR INFLATED RUBBER DAM.
DOMINGUE GAP	DEEP BASINS	1957-58	54	31	-	20	234	1	SOUTH OF DEL AMO BOULEVARD. AND BORDERS THE EASTERN AND WESTERN SIDES OF THE LOS ANGELES RIVER.	CONTROLLED FLOW FROM LOS ANGELES RIVER LOW FLOW CHANNEL AND UNCONTROLLED FLOWS FROM STORM DRAINS.	EAST SIDE BASIN USED FOR FLOOD REGULATION WITH SOME CONSERVATION STORAGE. INTAKE CAPACITY IS 20 CFS FOR LOW FLOW DIVERSION FROM THE LOS ANGELES RIVER. THE WEST SIDE BASIN IS FED BY A 42-INCH CONCRETE PIPE FROM THE EAST SIDE BASIN.
EATON BASIN	DEEP BASIN	1956-57	16	11	9,600	400	284	10	EAST SIDE OF EATON WASH, NORTH OF DUARTE ROAD, 0.6 MILES SOUTH OF HUNTINGTON DRIVE.	CONTROLLED FLOW FROM EATON WASH DAM AND UNCONTROLLED FLOWS BETWEEN DAM AND SPREADING BASIN.	
EATON WASH	DEEP & SHALLOW BASINS	1947-48	28	24	6,600	100	525	17	EASTERLY SIDE OF EATON WASH FROM BELOW EATON DAM TO FOOTHILL BOULEVARD.	CONTROLLED FLOW FROM EATON WASH DAM.	
FORBES	MEDIUM DEPTH BASINS	1964-65	21	8.8	-	100	87	5	SOUTH SIDE OF SAN DIMAS WASH BETWEEN LOWE HILL AVENUE AND VALLEY CENTER AVENUE.	CONTROLLED RELEASES FROM PUDDINGSTONE DIVERSION DAM, AND UNCONTROLLED FLOWS FROM SAN DIMAS WASH; ALSO IMPORTED FROM SOVND.	RECONSTRUCTION OF BASINS, FROM SHALLOW TO MEDIUM DEPTHS WAS COMPLETED IN APRIL 1989.
HANSEN	SHALLOW BASINS	1944-45	156	110	22,000	400	320	250	NORTHWESTERLY SIDE OF TUJUNGA WASH FROM ABOVE GLENDALE BOULEVARD SOUTHWESTERLY TO SAN FERNANDO ROAD.	CONTROLLED FLOWS FROM HANSEN DAM AND BIG TUJUNGA DAM.	
IRVINDALE	DEEP BASIN	1958-59	17	14	20,000	450	429	15	NORTHEASTERLY OF INTERSECTION OF BIG DALTON CHANNEL AND IRVINDALE AVENUE; CONTAINS 1,300 FEET EAST OF IRVINDALE AVENUE.	BIG DALTON CHANNEL CONTROLLED FLOWS FROM BIG AND LITTLE DALTON DERRIS DAMS AND PUDDINGSTONE DIVERSION DAM; UNCONTROLLED FLOWS; ALSO IMPORTED WATER FROM C848 AND SOVND.	
LITTLE DALTON	SHALLOW BASINS	1931-32	14	5	-	20	5	15	WESTERLY OF GLENDALE MT. ROAD, FROM LITTLE DALTON DERRIS BASIN SOUTH TO EAST PALM DRIVE.	CONTROLLED FLOW FROM LITTLE DALTON DERRIS BASIN.	
LIVE OAK	SHALLOW BASINS	1961-62	5	2	-	15	2	13	WESTERLY SIDE OF LIVE OAK WASH. NORTH OF BASE LINE ROAD (PROJECTED).	CONTROLLED FLOW FROM LIVE OAK DAM AND LIVE OAK DERRIS BASIN.	
LOPEZ	SHALLOW BASINS	1956-57	18	12	-	20	23.6	15	SOUTHEASTERLY SIDE OF PACOIMA WASH, NORTHEASTERLY OF FOOTHILL BOULEVARD.	CONTROLLED FLOW FROM PACOIMA DAM AND LOPEZ FLOOD CONTROL BASIN.	

* THE CAPACITIES LISTED ARE BASED ON INFILTRATION RATES WHICH MAY BE EXPECTED TO PERSIST FOR AT LEAST FIVE DAYS BUT ARE NOT VALID FOR SUSTAINED SPREADING OPERATIONS.

** DESIGN CAPACITY OF MAIN CONCRETE CHANNEL.

LOS ANGELES COUNTY DEPARTMENT OF PUBLIC WORKS
WATER CONSERVATION DIVISION

SUMMARY OF DATA ON SPREADING FACILITIES
OWNED AND OPERATED BY THE DEPARTMENT
UPDATED THROUGH SEPTEMBER 1990

SPREADING FACILITY	TYPE	SEASON FIRST USED	AREA IN ACRES		CAPACITIES				LOCATION	SOURCE OF WATER	REMARKS
			GROSS	NETTED	CHANNEL**	LEVEE	STORAGE	PERCOLATION*			
PACIFICA	MEDIUM DEPTH BASINS	1932-33	169	107	17,000	600	640	50	BOTH SIDES OF OLD PACIFICA WASH CHANNEL FROM ANIETA AVENUE SOUTHWESTERLY TO WOODMAN AVENUE.	CONTROLLED FLOW FROM PACIFICA DAM. PARTIALLY CONTROLLED FLOW FROM LOSPE FLOOD CONTROL BASIN. UNCONTROLLED FLOW FROM EAST CANYON AND PACIFICA WASH. IMPORTED WATER FROM OWENS VALLEY DELIVERED BY CITY OF LOS ANGELES.	
PECK ROAD	DEEP BASIN	1959-60	157	85	30,100	30,100	3,347	25	CONFLUENCE OF SAWPIT AND SANTA ANITA WASHES.	CONTROLLED RELEASES FROM SANTA ANITA AND SAWPIT DEBRIS BASINS AND UNCONTROLLED FLOWS FROM LOCAL RUNOFF VIA SAWPIT AND SANTA ANITA WASHES.	INSTREAM SPREADING FACILITY
RIO HONDO COASTAL	MEDIUM DEPTH BASINS	1937-38	570	400	40,000	1950	3,694	400	EASTERLY SIDE OF RIO HONDO SOUTHERLY FROM U.F.R.R. (SOUTH OF WHITTIER BLVD.) TO SLAUSON AVENUE; WEST SIDE OF RIO HONDO CHANNEL FROM 0.2 MILE ABOVE WHITTIER BOULEVARD SOUTH TO FOSTER BRIDGE BOULEVARD.	CONTROLLED RELEASES FROM SAN GABRIEL CANYON DAMS, SANTA FE AND WHITTIER NARROWS DAMS. UNCONTROLLED RUNOFF VIA SAN GABRIEL RIVER, RIO HONDO CHANNEL AND THEIR TRIBUTARIES; ALSO IMPORTED AND RECLAIMED WATER.	IN COOPERATION WITH THE CORPS OF ENGINEERS. THE DISTRICT OPERATES 2,500 ACRE-FOOT POOL AT WHITTIER NARROWS DAM FOR RETENTION OF STORM WATERS.
SAN DIMAS CANYON	SHALLOW BASINS	1965-66	22	11	-	25	22	12	SOUTHEAST SIDE OF SAN DIMAS WASH BETWEEN PUDDINGSTONE DIVERSION AND SAN DIMAS CANYON ROAD.	CONTROLLED RELEASES FROM PUDDINGSTONE DIVERSION DAM; UNCONTROLLED FLOW FROM LOCAL STORM RUNOFF.	
SAN GABRIEL CANYON	DEEP BASINS	1917	165	-	-	150	-	35	EASTERLY SIDE OF SAN GABRIEL RIVER. BELOW MOUTH OF SAN GABRIEL CANYON. NORTH OF THE CITY OF AUSA.	SAN GABRIEL RIVER CONTROLLED RELEASES FROM COGNELL DAM, SAN GABRIEL DAM, AND MORRIS DAM. COMMITTEE OF NINE SURPLUS FLOWS.	
SAN GABRIEL COASTAL	MEDIUM DEPTH BASINS	1938-39	128	96	-	350	575	75	WESTERLY SIDE OF SAN GABRIEL RIVER, SOUTHERLY FROM WHITTIER BOULEVARD TO WASHINGTON BOULEVARD.	CONTROLLED RELEASES FROM SAN GABRIEL CANYON DAMS, SANTA FE AND WHITTIER NARROWS DAMS. UNCONTROLLED RUNOFF VIA RIO HONDO CHANNEL AND ITS TRIBUTARIES; ALSO IMPORTED AND RECLAIMED WATER.	IN COOPERATION WITH THE CORPS OF ENGINEERS. THE DISTRICT OPERATES 2,500 ACRE-FOOT POOL AT WHITTIER NARROWS DAM FOR RETENTION OF STORM WATERS.
SAN GABRIEL RIVER (HOWESKILLO FORBAY)	MEDIUM DEPTH BASINS	1954-55	156	156	20,000	550	1,462***	75	HEADWORKS TO FIRESTONE AVE ONLY. STORAGE BEHIND THE RUBBER DAMS.	SAME AS UPPER PORTION. ALSO RECLAIMED WATER.	FIVE RUBBER DAMS INSTALLED ON DROP STRUCTURES. WHEN INFLATED, CONVERTS RIVER BED TO SPREADING AREAS.
SAN GABRIEL RIVER (SAN GABRIEL VALLEY)	TEMPORARY CHECK LEVEES	1965-66	196	196	-	-	-	180	SAN GABRIEL RIVER FROM SANTA FE DAM.	CONTROLLED FLOW FROM DAMS IN SAN GABRIEL CANYON, SANTA FE DAM AND UNCONTROLLED VALLEY RUNOFF BELOW SANTA FE DAM; ALSO IMPORTED WATER.	CHECK LEVEES DEVELOPED IN RIVER TO SPREAD WATER.
SANTA ANITA	SHALLOW BASINS	1944-45	20	8.5	-	20	25	5	WESTERLY SIDE OF SANTA ANITA WASH 1.25 MILES ABOVE FOOTHILL BOULEVARD.	CONTROLLED FLOW FROM SANTA ANITA DAM AND SANTA ANITA DEBRIS BASIN.	THE HEADWORKS LOCATED UPSTREAM OF THE DEBRIS BASIN DIVERTS WATER TO SANTA ANITA SPREADING GROUNDS AND CITY OF SIERRA MADRE SPREADING GROUNDS.
SANTA FE AND MEDIUM DEPTH BASINS	SHALLOW AND MEDIUM DEPTH BASINS	1953-54	338	111	-	400	540	400	WITHIN SANTA FE DAM RESERVOIR AND SPILLWAY AREAS.	CONTROLLED FLOWS FROM SAN GABRIEL CANYON RESERVOIRS. UNCONTROLLED FLOWS FROM SAN GABRIEL RIVER BELOW MORRIS RESERVOIR; ALSO IMPORTED WATER FROM SGVWD AND USG-3.	RIGHT OF WAY, HELD UNDER LICENSE FROM THE FEDERAL GOVERNMENT INCLUDES 30 ACRES IN SAN GABRIEL RIVER BED FOR EACH DIVERSION LEVEE.
SAWPIT	SHALLOW BASINS	1946-47	12	3.8	-	30	13	12	WESTERLY SIDE OF SAWPIT WASH BELOW MOUTH OF CANYON NEAR OF WERUMBEGA DRIVE, MONROVIA.	CONTROLLED FLOWS FROM SAWPIT DAM AND SAWPIT DEBRIS BASIN.	
WALNUT	DEEP BASIN	1962-63	16	7.3	8,000	50	166	5	WEST SIDE OF WALNUT WASH, NORTH OF SAN BERNARDINO FREEWAY.	CONTROLLED FLOW FROM PUDDINGSTONE DAM AND UNCONTROLLED FLOWS FROM WALNUT WASH CHANNEL.	
TOTAL:			2,428 AC.	1,479 AC.	-	-	12,655 A.F.	1,701 CFS			

* THE CAPACITIES LISTED ARE BASED ON INFILTRATION RATES WHICH MAY BE EXPECTED TO PERSIST FOR AT LEAST FIVE DAYS BUT ARE NOT VALID FOR SUSTAINED SPREADING OPERATIONS.

** DESIGN CAPACITY OF MAIN CONCRETE CHANNEL.

*** INCLUDES RUBBER DAMS STORAGE

LOS ANGELES COUNTY DEPARTMENT OF PUBLIC WORKS
WATER CONSERVATION DIVISION

SUMMARY OF DATA ON SPREADING FACILITIES
NOT OWNED BY THE DEPARTMENT
UPDATED THROUGH SEPTEMBER 1990

GROUNDS -----	TYPE ---	SEASON FIRST USED -----	AREA IN ACRES		CAPACITIES				LOCATION -----	SOURCE OF WATER -----	REMARKS -----
			GROSS	NETTED	CHANNEL**	INTAKE	STORAGE	PERCOLATION			
					CFS	CFS	A.F.	CFS			
SIERRA MADRE (CITY OF SIERRA MADRE)	SHALLOW BASINS	ABOUT 1933	22	9	-	25	47	15	CITY OF SIERRA MADRE, SOUTH SIDE OF GRANDVIEW AVENUE, ONE HALF MILE WEST OF SANTA ANITA AVENUE.	LITTLE SANTA ANITA CREEK AND STREET RUNOFF ALSO CONTROLLED FLOWS FROM SANTA ANITA DAM.	
FISH CANYON (COMMITTEE OF NINE)	SHALLOW BASINS	ABOUT 1917	6	4	-	-	-	7	WESTERLY SIDE OF SAN GABRIEL RIVER BELOW MOUTH OF FISH CANYON AND NORTH OF THE CITY OF AZUSA.	THE 'COMMITTEE OF NINE'.	OWNED AND OPERATED BY CAL-AMERICAN WATER COMPANY.
THOMPSON CREEK POMONA VALLEY PROTECTIVE ASSOCIATION	DITCHES CHECKS AND DEEP BASIN	ABOUT 1928	53	37	-	35	-	15	SOUTHERLY FROM, AND ADJACENT TO THOMPSON CREEK DAM, EAST SIDE OF CREEK.	COBAL, WILLIAMS, PALMER, AND PADUA CREEKS, ALSO THOMPSON CREEK, WHEN RESERVOIR ABOVE ELEVATION 1,625.	OPERATED BY POMONA VALLEY PROTECTIVE ASSOCIATION.
SAN ANTONIO	DITCHES CHECKS AND SHALLOW	1921-22	598	300	8,000	500	-	300	BOTH SIDES OF SAN ANTONIO CREEK FROM TWO AND ONE HALF MILES ABOVE BASE LINE SOUTH-WESTERLY TO BASE LINE.	CONTROLLED RELEASES FROM THE SAN ANTONIO FLOOD CONTROL DAM.	OPERATED BY POMONA VALLEY PROTECTIVE ASSOCIATION. WEST SIDE OF CHANNEL 500 ACRES. EAST SIDE OF CHANNEL 98 ACRES. IN ADDITION THERE ARE 207 ACRES EAST OF CHANNEL IN SAN BERNARDINO COUNTY; WATER SPREAD IN VICINITY ON AND OFF AS EARLY AS ABOUT 1896.
HEADWORKS (CITY OF LOS ANGELES)	SHALLOW BASINS	1938-39	48	28	57,000	-	40	40	SAN FERNANDO VALLEY, SOUTH OF LOS ANGELES RIVER, ABOVE MARIPOSA STREET.	LOS ANGELES RIVER. PARTIALLY CONTROLLED BY VARIOUS DAMS. RELEASE OF OWENS VALLEY WATER FROM CHATSWORTH RESERVOIR. GROUNDWATER FROM WELLS IN THE WEST END OF SAN FERNANDO VALLEY.	
TUJUNGA (L.A. CITY DEPT. OF WATER AND POWER) ***	SHALLOW BASINS	1931-32	188	130	22,000	400	-	390	SAN FERNANDO VALLEY, EAST SIDE OF TUJUNGA WASH AT ROSCOE BOULEVARD.	LOS ANGELES CITY'S OWENS VALLEY AQUEDUCT AND CONTROLLED RELEASES FROM HANSEN DAM.	PRIOR TO 1938 FLOOD, USED 80 ACRES NET. TUJUNGA CHANNEL ON WESTERLY SIDE OF GROUNDS PAVED IN 1950.
SAN ANTONIO CITY OF POMONA	DITCHES CHECKS, SHALLOW AND DEEP BASINS	(SEE REMARKS)	10	8	-	-	-	-	NORTH OF CLAREMONT, ONE HALF MILE NORTH OF FOOTHILL BOULEVARD AND ONE-EIGHTH MILE WEST OF MILLS AVENUE.	SAN ANTONIO CREEK WATER DELIVERED THROUGH LOOP RESERVE CANYON WATER COMPANY'S PIPE LINE. ALSO SOME LOCAL RUNOFF.	WATER SPREAD IN VICINITY ON AND OFF SINCE ABOUT 1897. GROUND ACQUIRED BY CITY OF POMONA, OCTOBER 1926. NO RECORD OF WATER SPREAD PRIOR TO 1949-50.
TOTALS:			925	516	-	-	-	-			

* THE CAPACITIES LISTED ARE BASED ON INFILTRATION RATES WHICH MAY BE EXPECTED TO
PERSIST FOR AT LEAST FIVE DAYS BUT ARE NOT VALID FOR SUSTAINED SPREADING OPERATIONS.

** DESIGN CAPACITY OF MAIN CONCRETE CHANNEL.

*** THE DEPARTMENT ENTERED INTO AN AGREEMENT WITH THE CITY OF LOS ANGELES TO OPERATE
THIS FACILITY.

**WATER CONSERVED ALL FACILITIES
WATER YEAR : 1989 - 1990**

BASINS	SPREADING FACILITIES	MONTHS: OCTOBER	NOVEMBER	DECEMBER	JANUARY	FEBRUARY	MARCH	APRIL	MAY	JUNE	JULY	AUGUST	SEPTEMBER	ACCUMULATIVE TOTALS
SAN FERNANDO VALLEY	BRANFORD	13.7	24.4	0.4	101.3	141.4	10.5	5.8	29.2	0.2	0.4	13.1	0.4	340.8
	HANSEN	0.0	0.0	169.0	112.0	404.0	576.0	359.0	163.0	59.0	91.0	32.0	64.0	2,029.0
	LOPEZ	0.0	0.0	0.0	0.0	0.4	0.0	0.0	90.0	0.0	0.0	0.0	0.0	90.4
	PACOINA	0.5	0.0	0.0	307.0	553.0	9.9	414.0	422.0	0.9	0.0	0.0	0.0	1,707.3
	SUBTOTAL	14.2	24.4	169.4	520.3	1,098.8	596.4	778.8	704.2	60.1	91.4	45.1	64.4	4,167.5
SAN GABRIEL VALLEY	ARROYO SECO	1.2	0.0	0.0	46.0	87.0	1.0	23.0	5.8	0.0	0.0	0.0	0.0	164.0
	BEN LOMOND	0.0	0.0	0.0	0.0	0.0	230.0	187.0	0.3	0.0	0.0	5.3	0.0	422.6
	BIG DALTON	0.0	0.0	0.0	0.0	0.0	0.0	0.0	0.0	0.0	0.0	0.0	0.0	0.0
	BUENA VISTA	37.6	33.9	34.5	45.2	45.5	51.2	47.7	43.3	42.2	38.4	46.7	50.0	516.2
	CITRUS	24.0	1.9	14.0	48.0	22.0	19.0	0.8	0.0	0.0	0.0	0.0	5.2	134.9
	EATON BASIN	40.0	29.0	25.0	260.0	262.0	39.0	73.0	85.0	9.1	33.0	27.0	21.0	903.1
	EATON GROUNDS	0.0	0.0	0.0	0.0	29.0	11.0	2.4	4.2	0.0	0.0	0.0	0.0	46.6
	FORBES	126.0	103.0	0.0	0.0	0.0	117.0	290.0	260.0	229.0	194.0	182.0	100.0	1,601.0
	IRWINDALE	161.0	193.0	0.0	207.0	114.0	117.0	151.0	0.0	0.0	0.0	0.0	0.0	943.0
	LITTLE DALTON	0.0	0.0	0.0	0.2	11.0	0.0	0.0	0.1	0.0	0.0	0.0	0.0	11.3
	LIVE OAK	0.0	0.0	0.5	0.0	3.1	0.0	0.0	0.0	0.0	0.0	0.0	0.0	3.6
	MORRIS TO STA. F190	2,785.0	1,000.0	767.2	1,073.0	3,250.0	3,417.0	3,266.0	264.7	99.2	97.3	5,970.0	5,567.0	27,556.4
	STA. F190 TO SANTA FE DAM	1,124.0	1,222.0	18.6	35.2	330.0	204.0	232.0	32.1	0.0	0.0	225.0	146.0	3,568.9
	PECK ROAD	34.4	48.3	6.1	377.4	502.0	28.6	89.1	177.3	4.0	0.8	4.6	4.2	1,276.8
	SAN DIMAS CANYON	0.0	0.0	0.0	0.8	17.5	0.0	0.0	7.7	101.0	0.0	0.0	0.0	127.0
	SAN GABRIEL CANYON SPR. CRDS.	517.0	104.0	2,120.0	984.0	2,200.0	2,320.0	1,150.0	235.0	346.0	146.0	125.0	0.0	10,247.0
	SANTA ANITA	0.0	0.0	0.0	0.0	4.9	0.0	0.0	0.0	0.0	0.0	0.0	0.0	4.9
	SANTA FE SPED. GROUNDS	0.0	0.0	0.0	16.0	1,110.0	4,070.0	4,630.0	641.0	0.0	0.0	1,880.0	1,250.0	13,597.0
	SANTA FE TO STA. F261	0.0	0.0	0.0	0.0	224.0	0.0	0.0	0.0	0.0	0.0	0.0	0.0	224.0
	SANTA FE DIVERSION	0.0	0.0	0.0	0.0	0.0	0.0	0.0	0.0	0.0	0.0	0.0	0.0	0.0
SAWPIT	0.0	0.0	38.0	65.0	90.0	54.0	14.0	31.0	48.0	27.0	0.0	0.0	367.0	
WALNUT	75.0	157.0	114.0	98.0	218.0	121.0	124.0	50.0	99.0	89.0	96.0	90.0	1,331.0	
F261 TO WHITTIER NARROWS DAM	2,554.3	2,159.2	188.9	3,017.6	7,141.4	3,170.0	3,472.0	4,582.6	1,958.3	2,299.3	4,128.5	4,565.2	39,237.3	
SUBTOTAL	7,479.5	5,051.3	3,326.8	6,273.4	15,661.4	13,969.8	13,752.0	6,420.1	2,935.8	2,924.8	12,690.1	11,798.6	102,283.7	
COASTAL PLAIN	RIO HONDO S.C.	78.0	6,381.2	1,642.0	7,130.0	9,776.8	8,016.7	10,636.0	9,092.0	5,935.0	4,934.7	2,960.0	6,514.0	73,096.4
	SAN GABRIEL S.C.*	7,381.2	3,423.3	4,735.2	3,321.0	3,265.4	5,612.0	4,672.2	867.6	1,619.0	16.1	3,217.0	3,870.0	42,000.0
	W.W. RESERVOIR (R.HONDO)	312.0	1,085.0	535.0	1,082.0	2,598.0	1,269.0	649.0	837.0	209.0	472.0	942.0	596.0	10,586.0
	DOMINGUEZ GAP	0.2	0.0	15.9	12.3	1.3	0.2	0.0	0.0	0.0	0.0	1.7	11.6	43.2
	SUBTOTAL	7,771.4	10,889.5	6,928.1	11,545.3	15,641.5	14,897.9	15,957.2	10,796.6	7,763.0	5,422.8	7,120.7	10,991.6	125,725.6
ANTELOPE VALLEY	BIG ROCK	0.0	0.0	0.0	8.9	8.5	6.1	0.0	0.0	0.0	0.0	0.0	0.0	23.5
OTHER FACILITIES	SIERRA MADRE	0.0	65.0	0.0	113.0	83.0	93.0	111.0	101.0	0.0	68.0	0.0	0.0	634.0
	THOMPSON CREEK	0.0	0.0	0.0	0.2	3.0	1.0	0.4	0.0	0.0	0.0	0.0	0.0	4.6
	FISH CREEK	114.8	96.8	121.0	150.9	117.6	280.0	221.6	258.4	250.6	240.0	233.3	108.1	2,193.1
	SUBTOTAL	114.8	161.8	121.0	264.1	203.6	374.0	333.0	359.4	250.6	308.0	233.3	108.1	2,831.7
GRAND TOTAL ALL WATER SPREAD & OR DIVERTED		15,379.9	16,127.0	10,545.3	18,612.0	32,613.8	29,844.2	30,821.1	18,280.3	11,009.5	8,747.0	20,089.2	22,962.7	235,032.0

NOTES: * : INCLUDES RIVER PERC.

**TOTAL WATER DELIVERED IN ACRE-FEET
WATER YEAR : 1989 - 1990**

MONTH	IMPORTED WATER OUTLET RELEASES									RECLAIMED WATER DELIVERED									
	SAN DINAS CB - 48	THOMPSON CREEK CB - 28	SAN CAB. RIVER CB - 37	ALHAMBRA CB - 36	OUTLET OLDEN ST. L.A. 699	RELEASERS USG 3 USGMWD	BEATTY CANYON SCVMWD	SAN DIMAS WH SCVMWD	IMPORTED MONTHLY	WHITTIER NARROWS PLANT				SAN JOSE PLANT				POMONA PLANT	RECLAIMED WATER SPREAD
										SPREAD		WASTED	MONTHLY SPREAD	SPREAD		WASTED	MONTHLY SPREAD		MONTHLY A.F.
										R.HONDO	S.GABRIEL			R.HONDO	S.GABRIEL				
OCTOBER	4,776.1	0.0	0.0	0.0	0.0	2,220.7	1,555.2	588.6	9,140.6	0.0	1,260.9	0.0	1,260.9	0.0	2,894.2	0.0	2,894.2	60.0	4,215.1
NOVEMBER	6,027.5	0.0	0.0	0.0	0.0	137.2	1,823.4	295.0	8,283.1	639.9	631.9	0.0	1,271.8	2,496.3	2,423.3	0.0	4,919.6	180.0	6,371.4
DECEMBER	213.7	0.0	0.0	0.0	0.0	2,357.4	97.8	0.0	2,668.9	638.8	636.4	0.0	1,275.2	944.5	4,255.2	0.0	5,199.7	190.0	6,664.9
JANUARY	0.0	2,091.2	0.0	0.0	0.0	1,713.0	0.0	0.0	3,804.2	952.5	161.2	1.9	1,111.8	1,972.4	1,786.0	7.7	3,750.7	200.0	5,062.5
FEBRUARY	3,136.6	3,943.1	0.0	0.0	0.0	6,465.5	0.0	0.0	13,545.2	1,151.9	0.0	18.5	1,133.4	308.4	25.9	49.1	285.2	250.0	1,668.6
MARCH	3,436.3	6,507.3	0.0	0.0	0.0	8,082.3	1,242.7	657.8	19,926.4	1,298.3	0.0	0.0	1,298.3	0.0	868.0	0.0	868.0	240.0	2,406.3
APRIL	7,441.8	3,640.7	0.0	390.7	377.5	8,925.7	0.0	2,138.2	22,914.6	1,270.0	0.0	0.0	1,270.0	0.0	1,094.2	0.0	1,094.2	200.0	2,564.2
MAY	0.0	260.9	0.0	589.3	0.0	0.0	758.5	1,511.9	3,120.6	1,374.0	0.0	2.4	1,371.6	3,870.6	1,118.6	1.3	4,987.9	100.0	6,459.5
JUNE	0.0	5,386.3	0.0	820.7	0.0	0.0	0.0	2,001.6	8,208.6	1,290.6	0.0	0.0	1,290.6	163.6	1,963.7	0.0	2,127.3	40.0	3,457.9
JULY	0.0	1,552.0	0.0	1,654.7	0.0	0.0	0.0	2,162.5	5,369.2	1,298.1	0.0	0.0	1,298.1	2,146.4	0.0	0.0	2,146.4	20.0	3,464.5
AUGUST	0.0	3,253.9	0.0	1,631.0	0.0	8,203.2	0.0	2,182.0	15,270.1	497.6	739.5	0.0	1,237.1	164.5	1,633.3	0.0	1,797.8	30.0	3,064.9
SEPTEMBER	0.0	6,870.2	0.0	1,992.9	0.0	7,147.6	0.0	2,119.9	18,130.6	477.0	772.5	0.0	1,249.5	2,673.2	754.9	0.0	3,428.1	30.0	4,707.6
TOTALS	25,032.0	33,505.6	0.0	7,079.3	377.5	45,252.6	5,477.6	13,657.5	130,382.1	10,888.7	4,202.4	22.8	15,068.3	14,739.9	18,817.3	58.1	33,499.1	1,540.0	50,107.4

NOTES : -THE AMOUNTS OF RECLAIMED WATER FROM POMONA PLANT ARE ESTIMATED.
-THE AMOUNTS OF WATER FROM CB-28 AND CB-48 DURING FEBRUARY 1990 ARE PART OF THE MAKE UP WATER.

WELL HYDROGRAPHS INCLUDED IN THIS REPORT

GROUND WATER BASIN	WELL NO.	APPROXIMATE LOCATION	PAGE NO.
WEST COAST	1346D 760C	11305 TRURO AVE., 250 FT. N. OF IMPERIAL HWY., COMPTON 99 FT. S.W. OF INTERSECTION OF COMPTON BLVD. & DOTY AVE., LAWDALE	G16
CENTRAL BASIN	460K 1601T 906D	2,600 FT. N.E. OF THE INTERSECTION OF LAKEWOOD BLVD. & PACIFIC COAST HWY., LONG BEACH 1,000 FT. S. OF THE INTERSECTION OF WASHINGTON BLVD. & ROSEMEAD BLVD., MONTEBELLO 1,300 FT. N.W. OF THE INTERSECTION OF LONG BEACH & SAN ANTONIO DR., LONG BEACH	G16 G17 G17
MAIN SAN GABRIEL	3030F 2955X	600 FT. N.W. OF THE INTERSECTION OF LOS ANGELES ST. & MAINE AVE., BALDWIN PARK TYLER AVE. & CENTRAL AVE., S. EL MONTE	G18 G19
SAN GABRIEL CANYON	4284A 4285	5,600 FT. N.W. OF THE INTERSECTION OF SIERRA MADRE AVE. & SAN GABRIEL CANYON RD., AZUSA 2,700 FT. N.W. OF SAN GABRIEL CANYON RD. & SIERRA MADRE AVE.	G19
POMONA	3251E 3241J 4469A	2,200 FT. N. OF THE INTERSECTION OF SAN BERNADINO FWY. & TOWNE AVE., POMONA 425 FT. S.W. OF LA VERNE AVE., 400FT. S.E. OF N. GAREY AVE. 739 FT. W. OF MOUNTAIN AVE., 1,025 FT. N. OF HARRISON AVE.	G20
CLAREMONT HEIGHTS	4508B 4508A	800 FT. S.E. OF THE INTERSECTION OF BASELINE RD. & PADUA AVE., CLAREMONT 270 FT. N.W. OF WELL 4508B	G21
RAYMOND	4057H	LOS ROBLES & GLENARM STREETS, PASADENA	G21
SANTA CLARA	7048A 7048C	S.E. OF THE INTERSECTION OF NEWHALL AVE. & MAGIC MOUNTAIN PARKWAY, SAUGUS 544 FT. W. OF W. CURB OF VALENCIA BLVD., 56 FT. S. OF MAGIC MOUNTAIN PARKWAY, VALENCIA	G22
ANTELOPE VALLEY	9974 8825	8,976 FT. S. OF AVE. K & 200 FT. W. OF SIERRA HWY., LANCASTER 25 FT. N. OF AVE. T & 45 FT. E. OF 90TH ST., LITTLE ROCK	G22 G23
MAIN SAN FERNANDO	3872H 4709	CLARK AVE. & GRIFFITH PARK DR., BURBANK SHERMAN WAY & DEERING AVE., CANOGA PARK	G23 G24

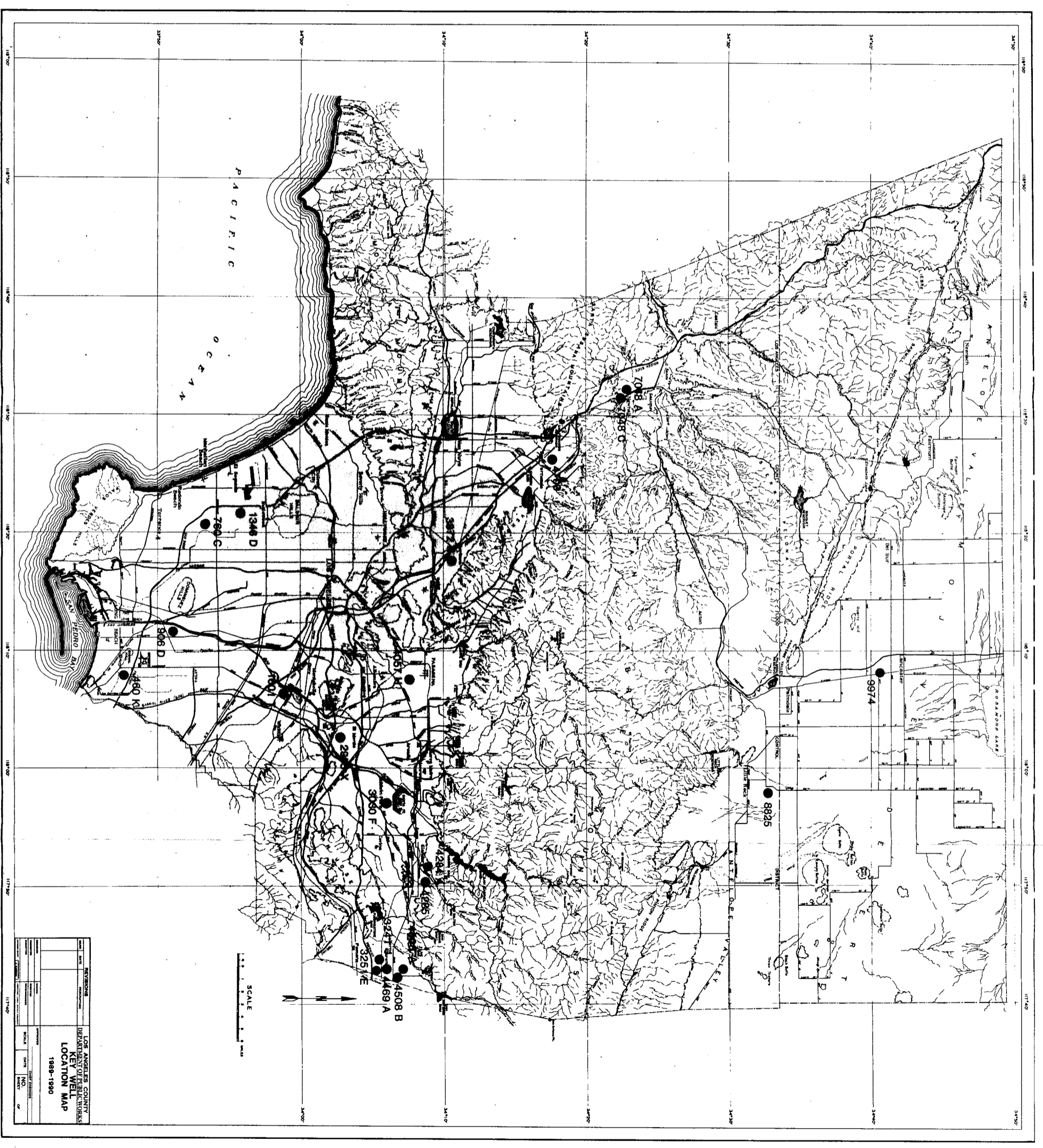

LOS ANGELES COUNTY
DEPARTMENT OF PUBLIC WORKS
KEY WELL
LOCATION MAP
1988-1990

NO.	NAME	REVISION	DATE	BY	CHKD.
1					
2					
3					
4					
5					
6					
7					
8					
9					
10					

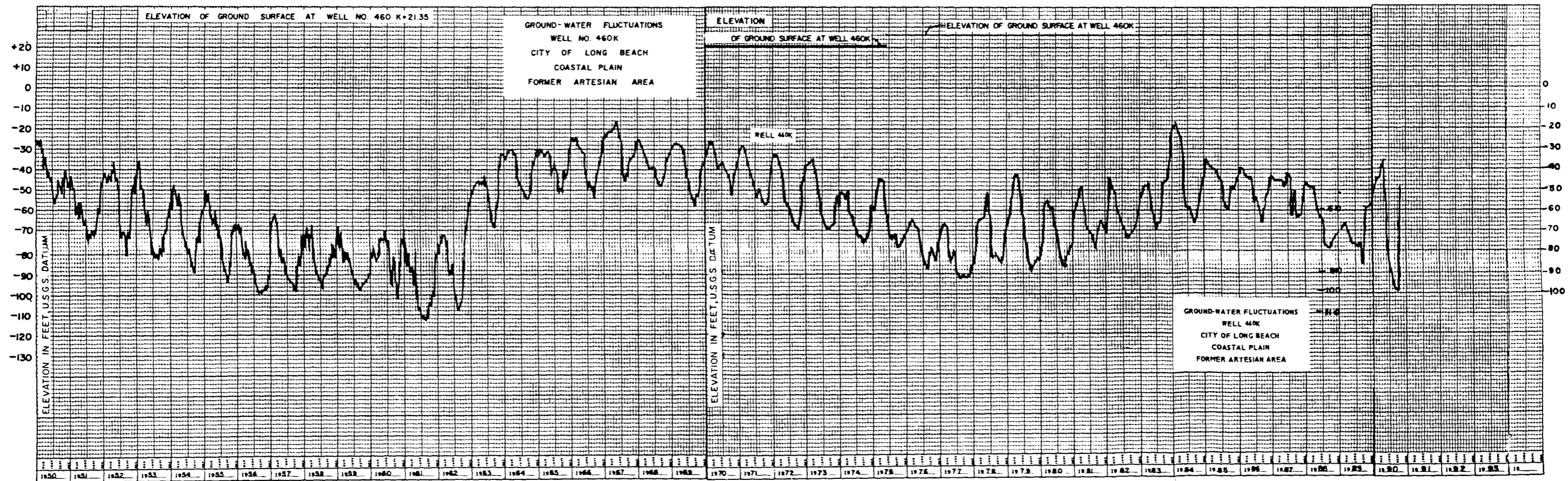
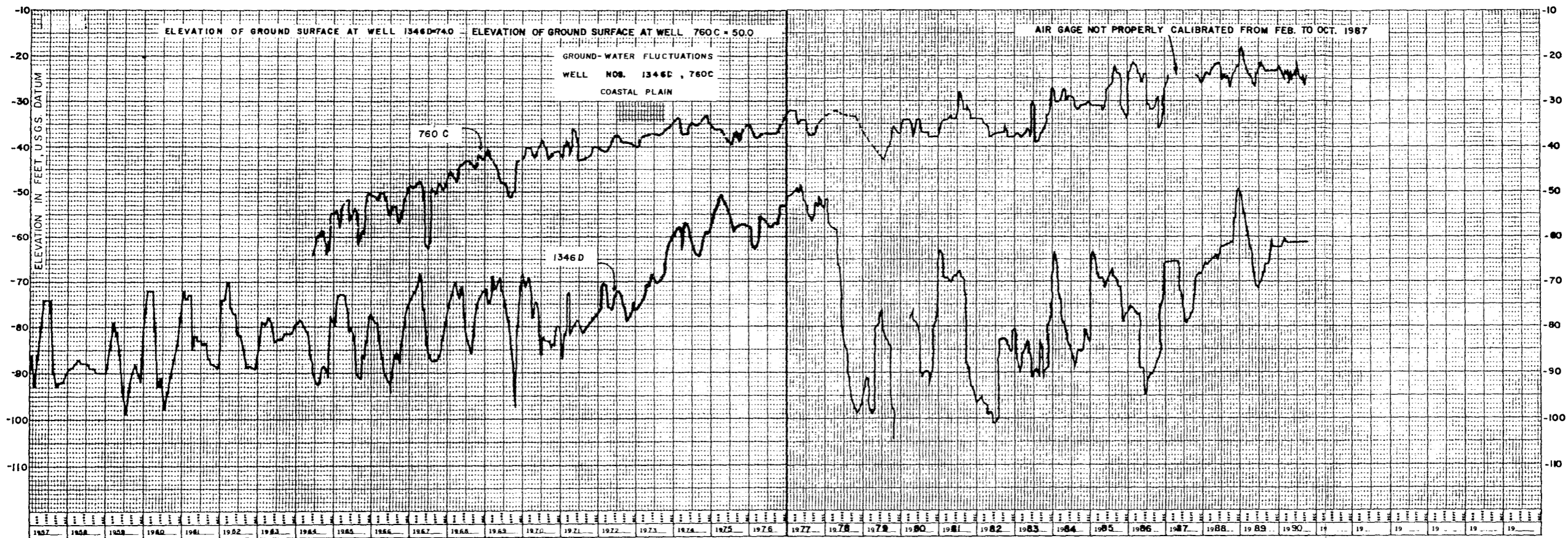

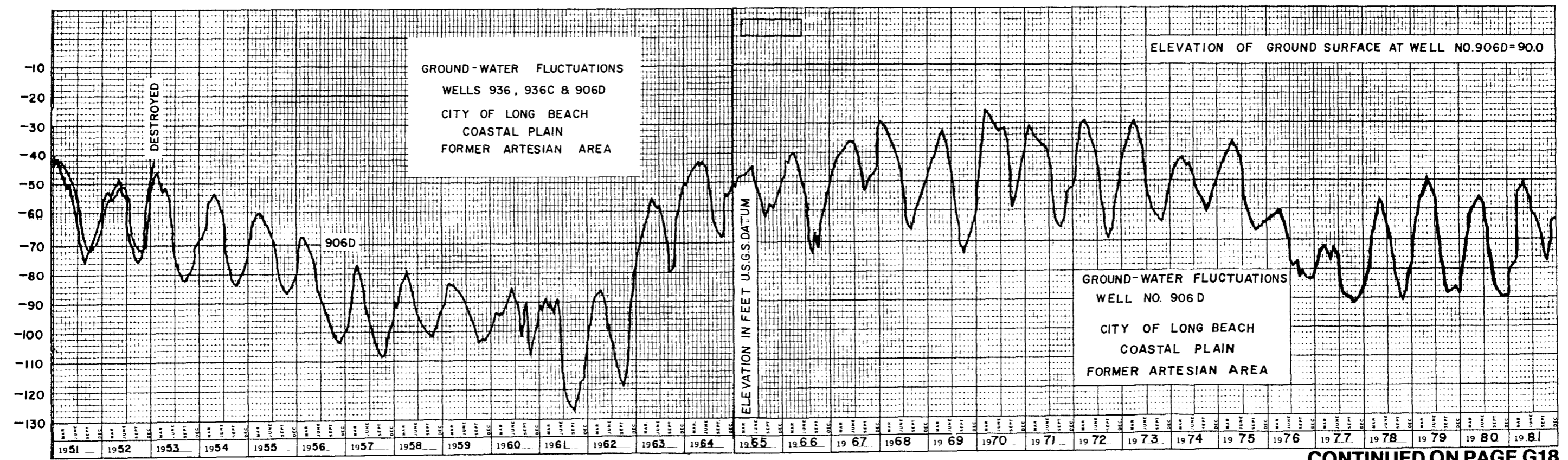
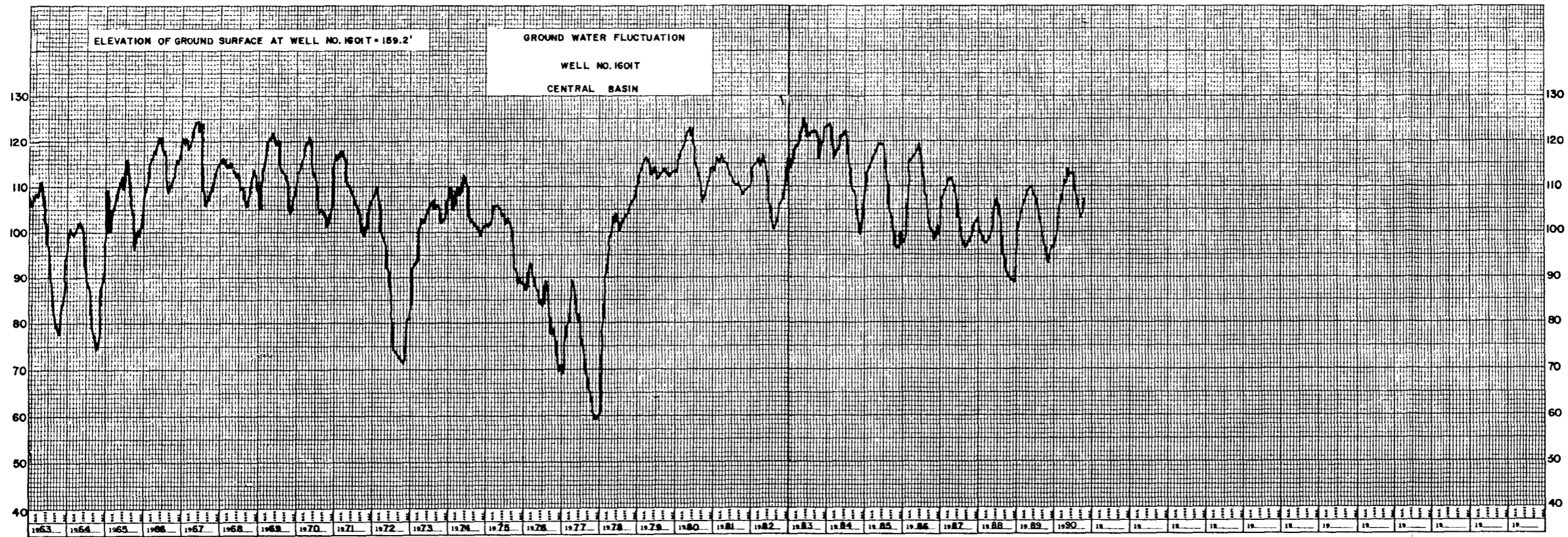

CONTINUED ON PAGE G18

WELL NO. 906D
 CONTINUED FROM PAGE G17

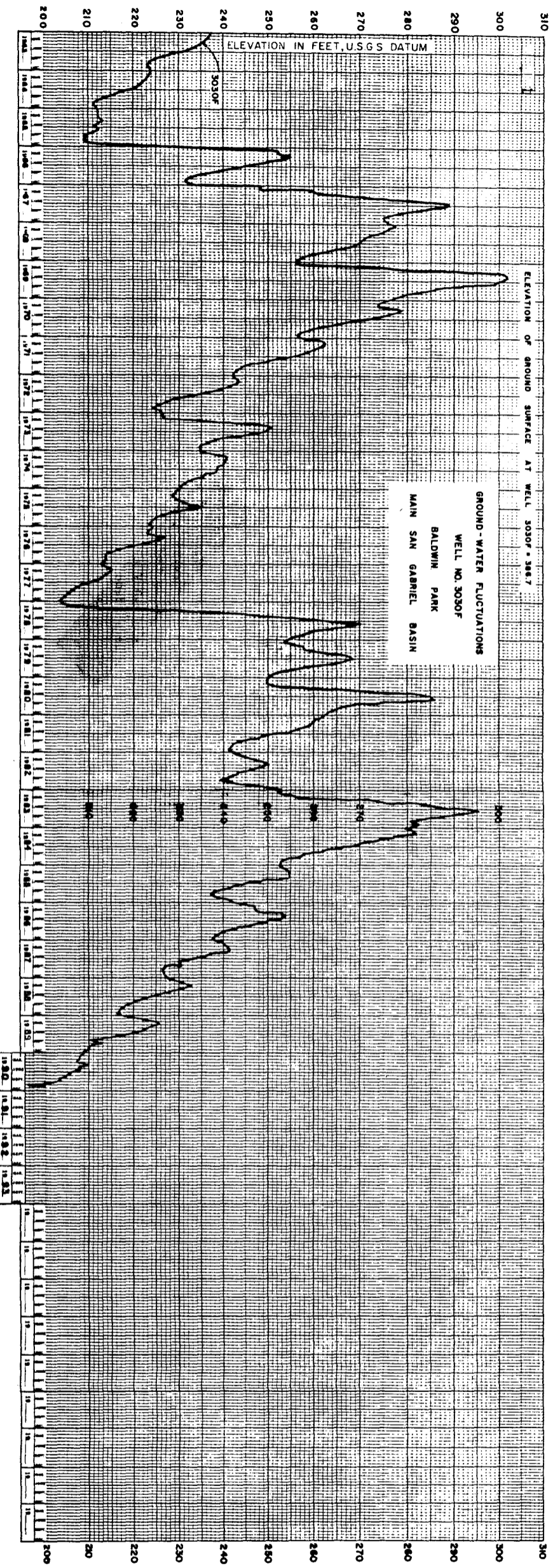
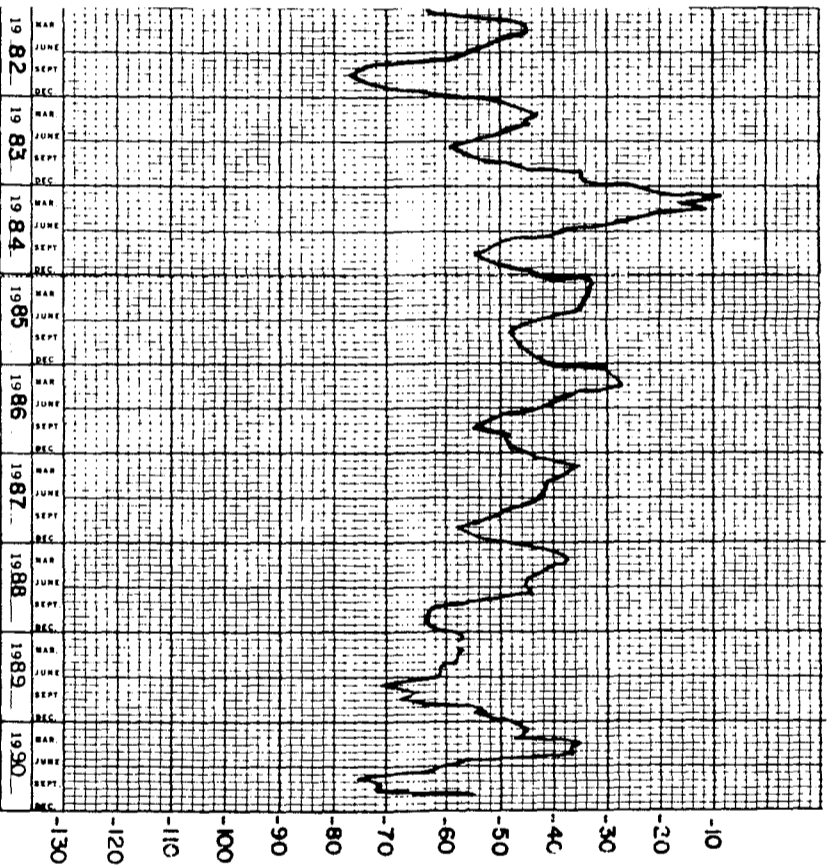

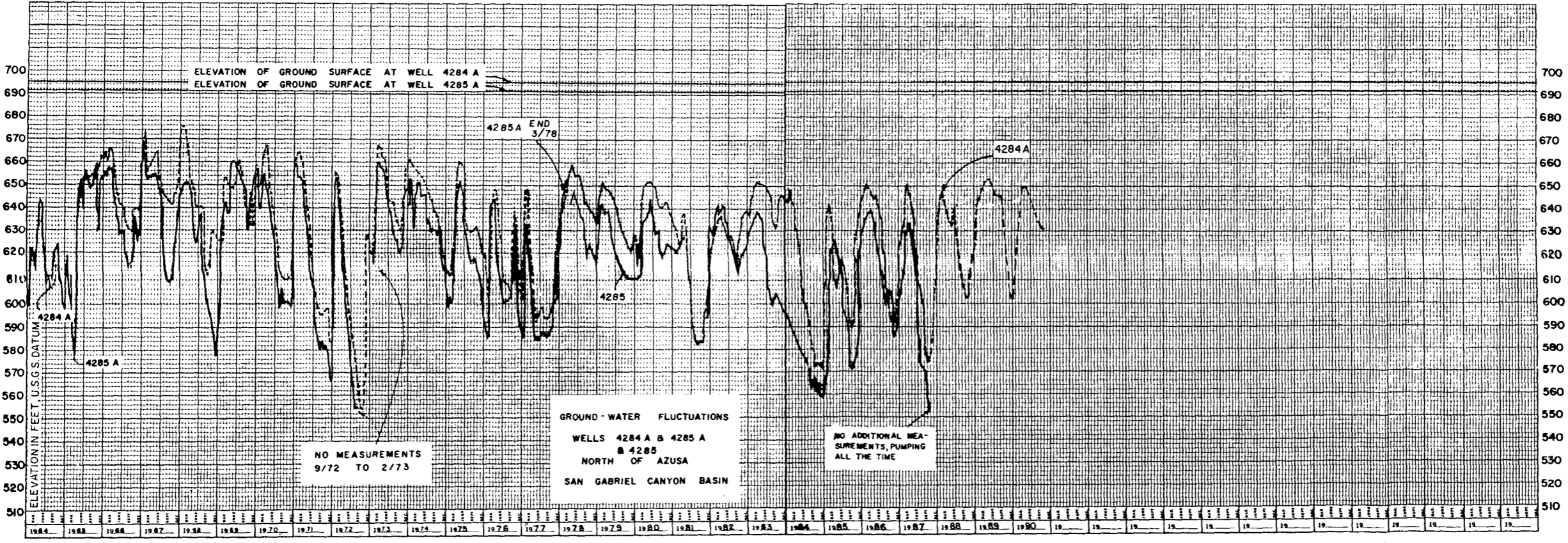
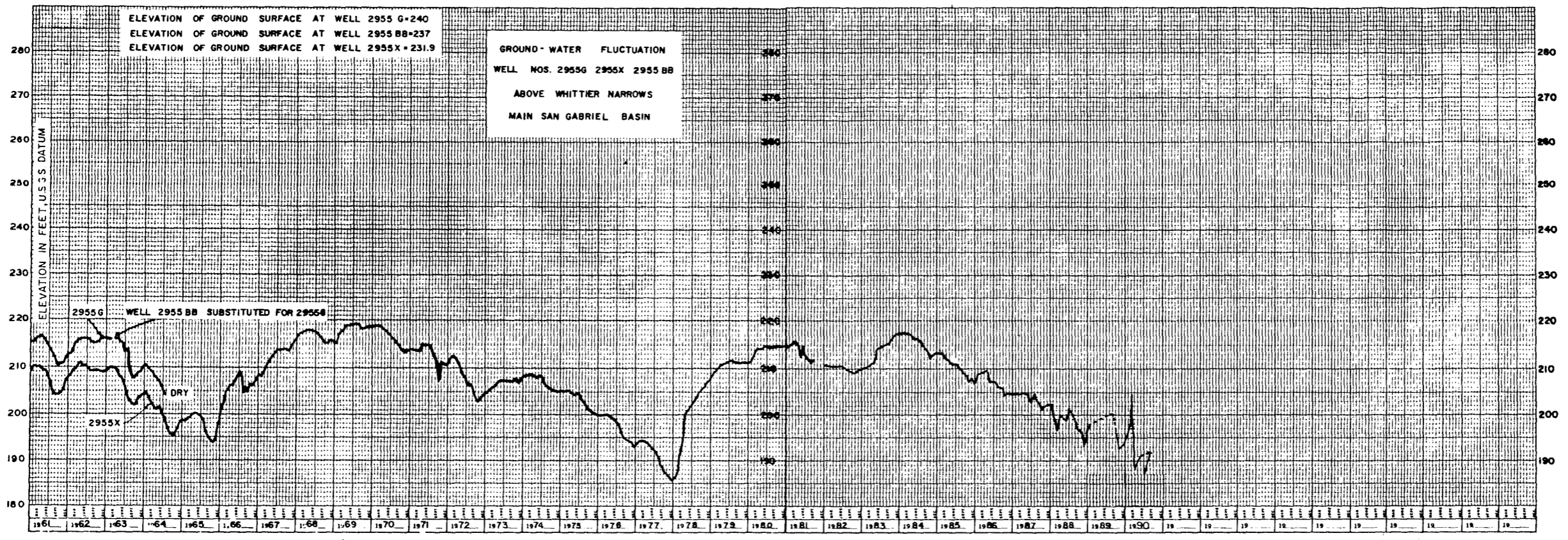

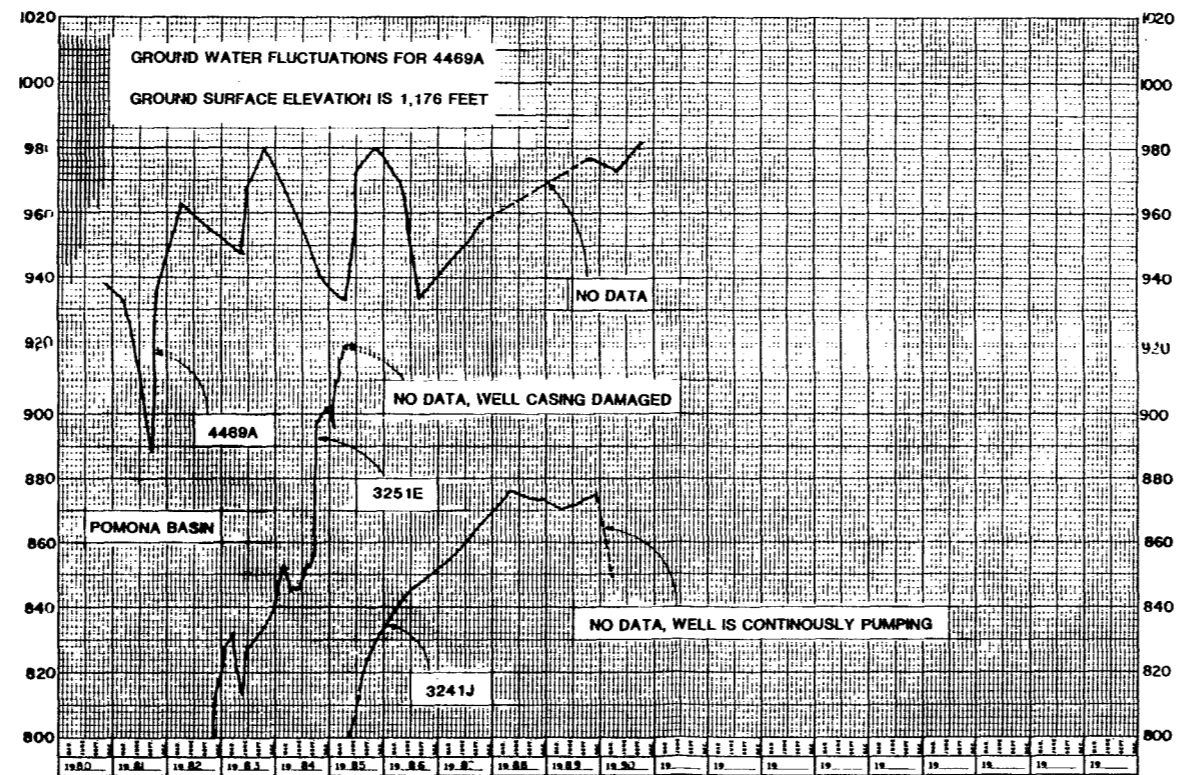
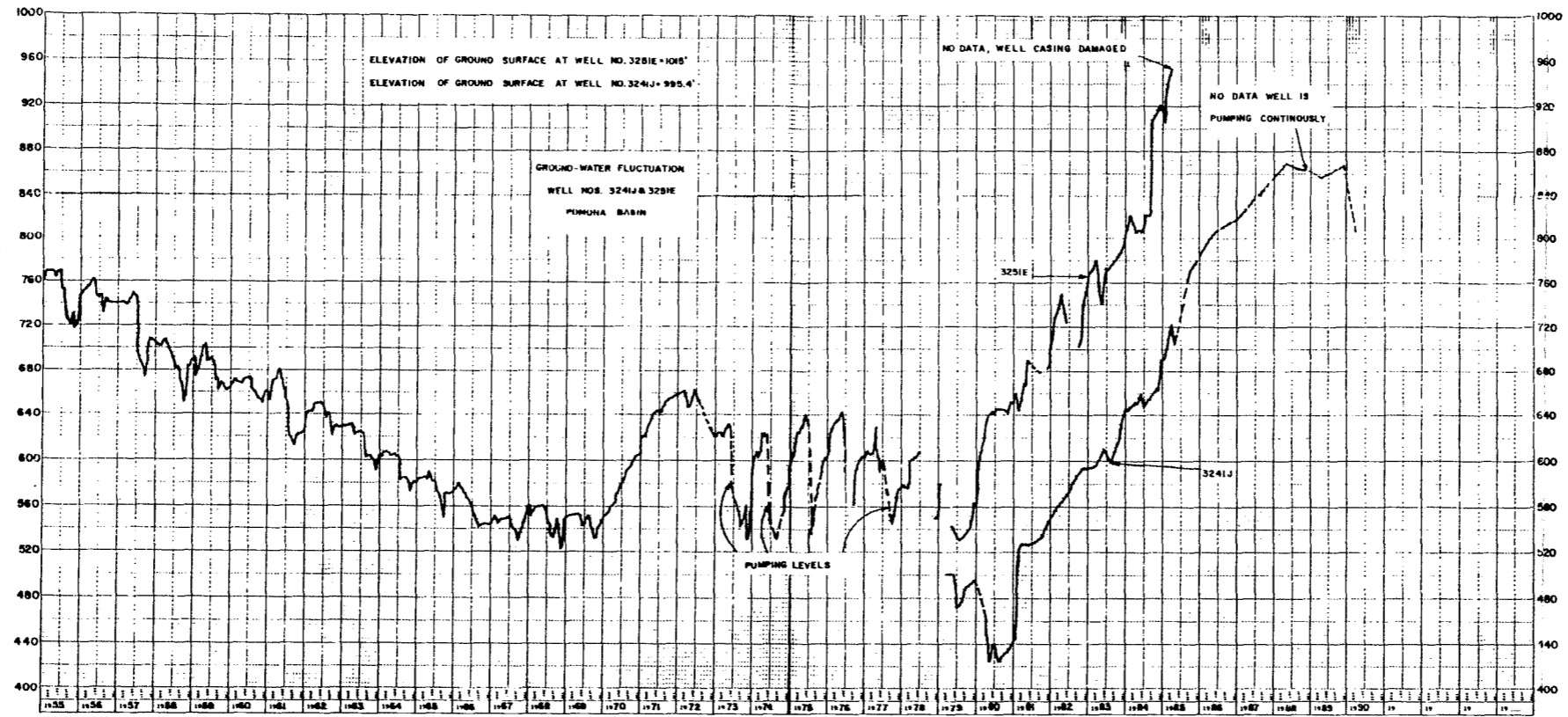

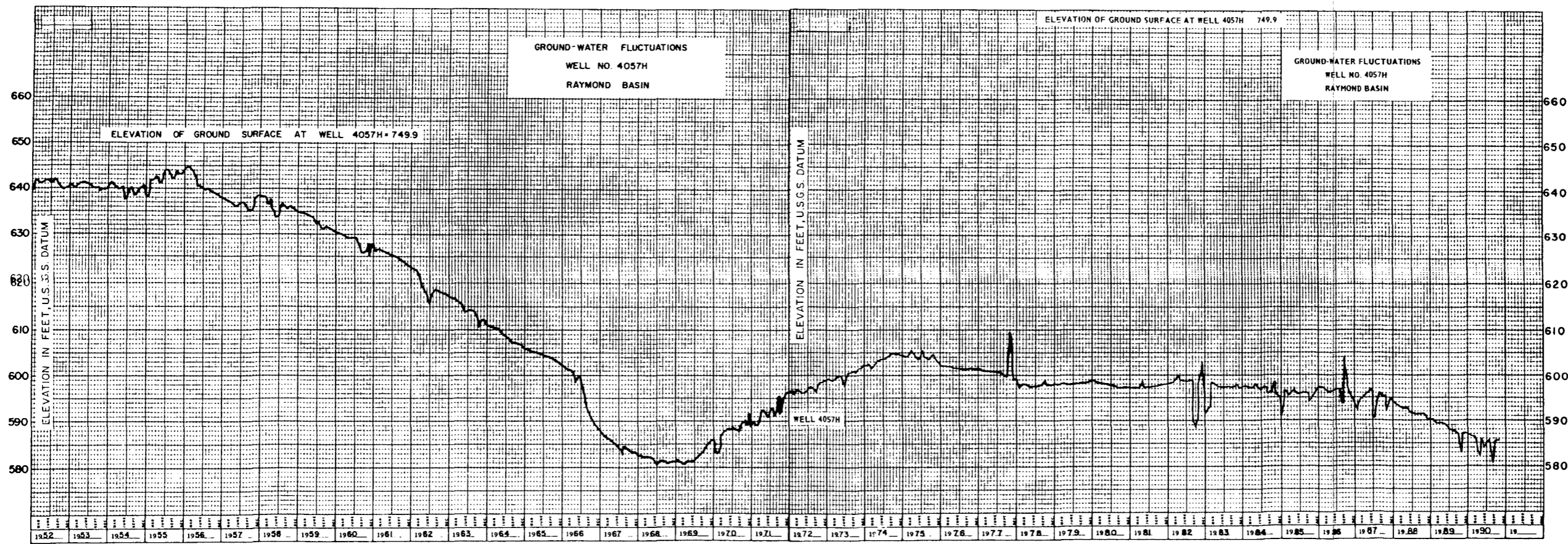
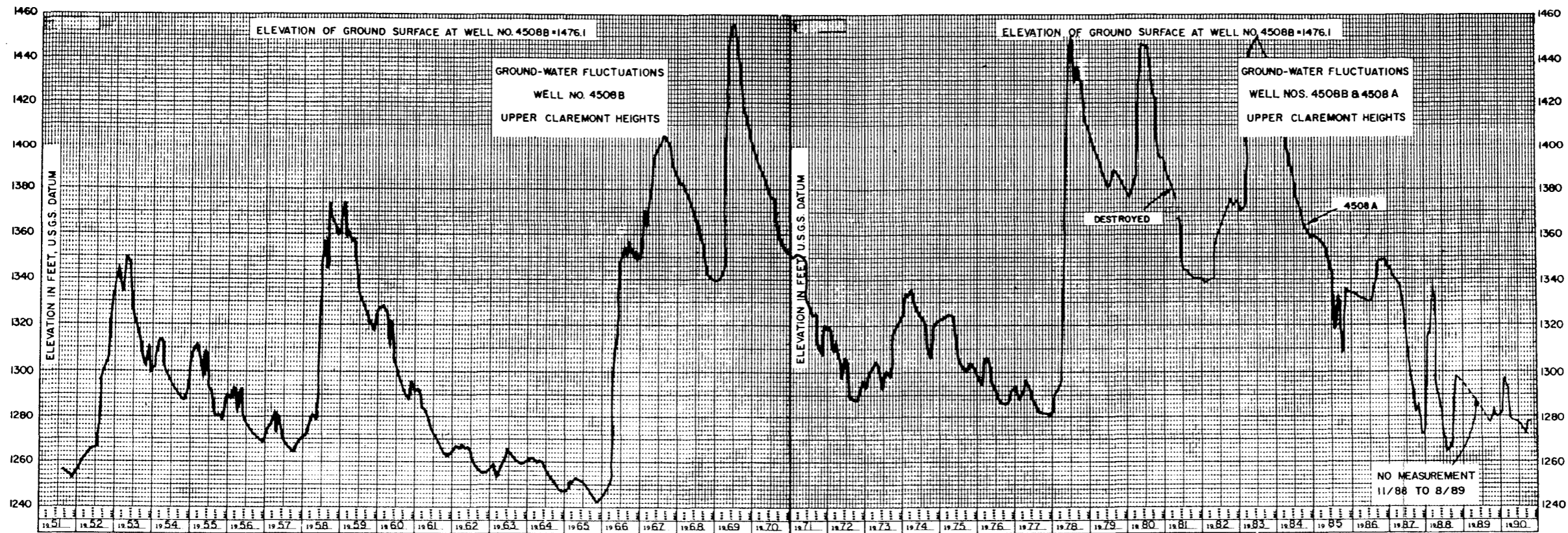

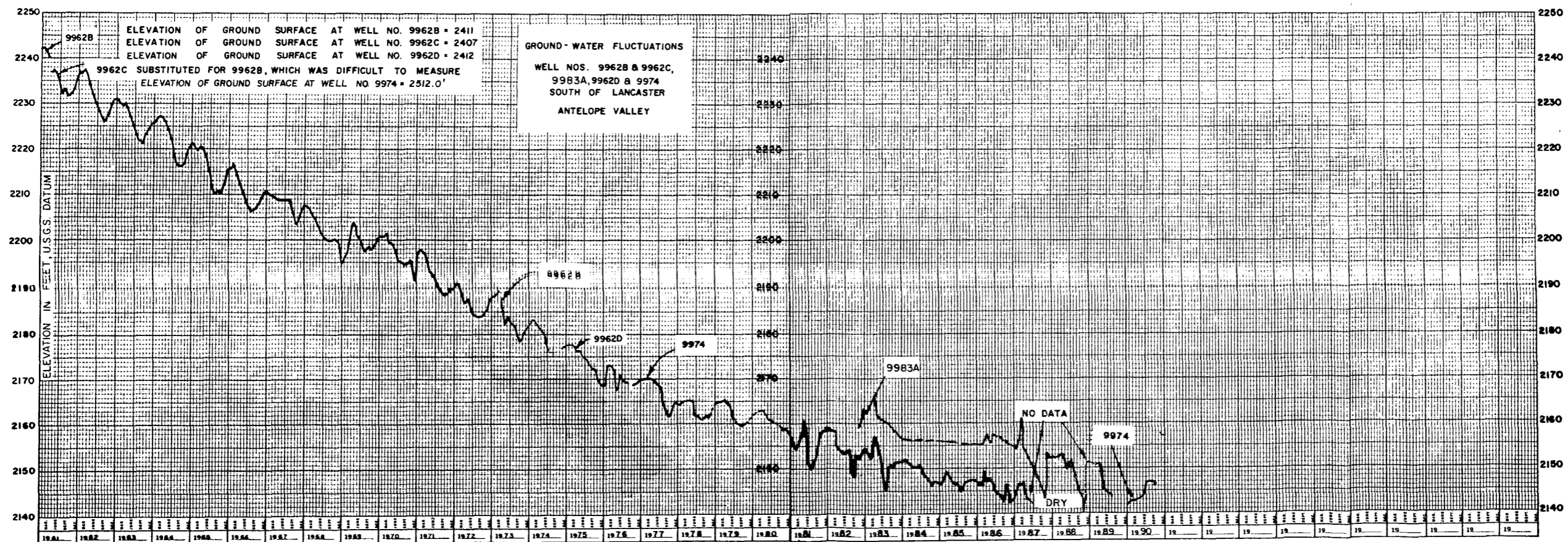
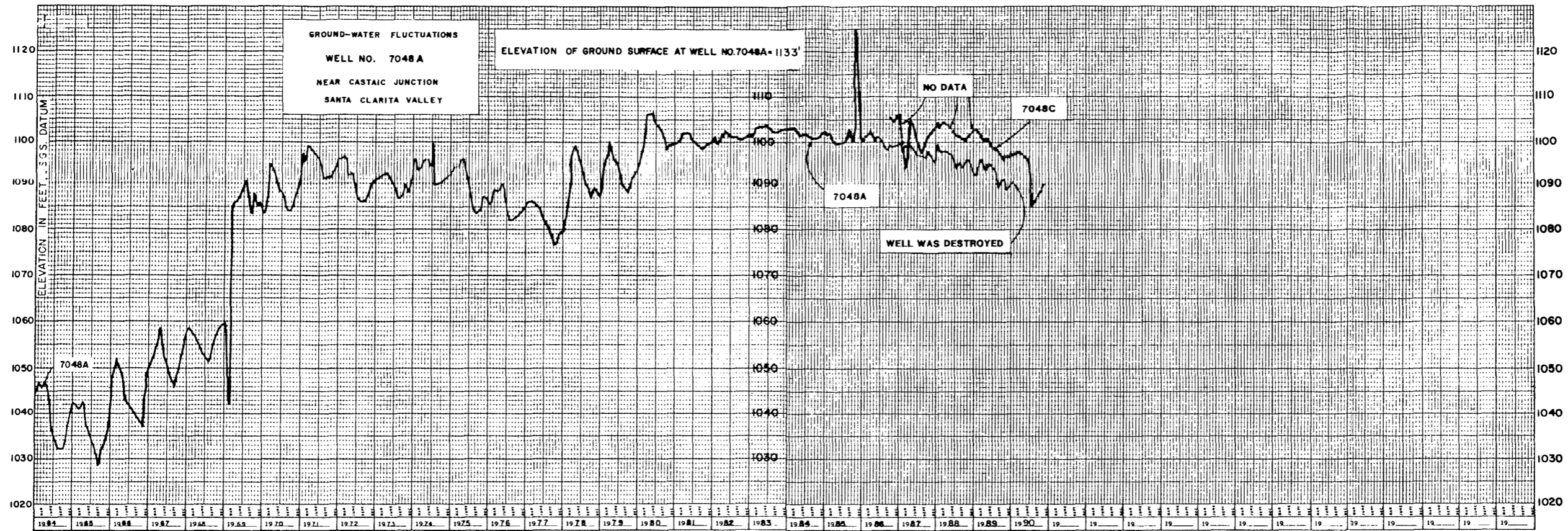

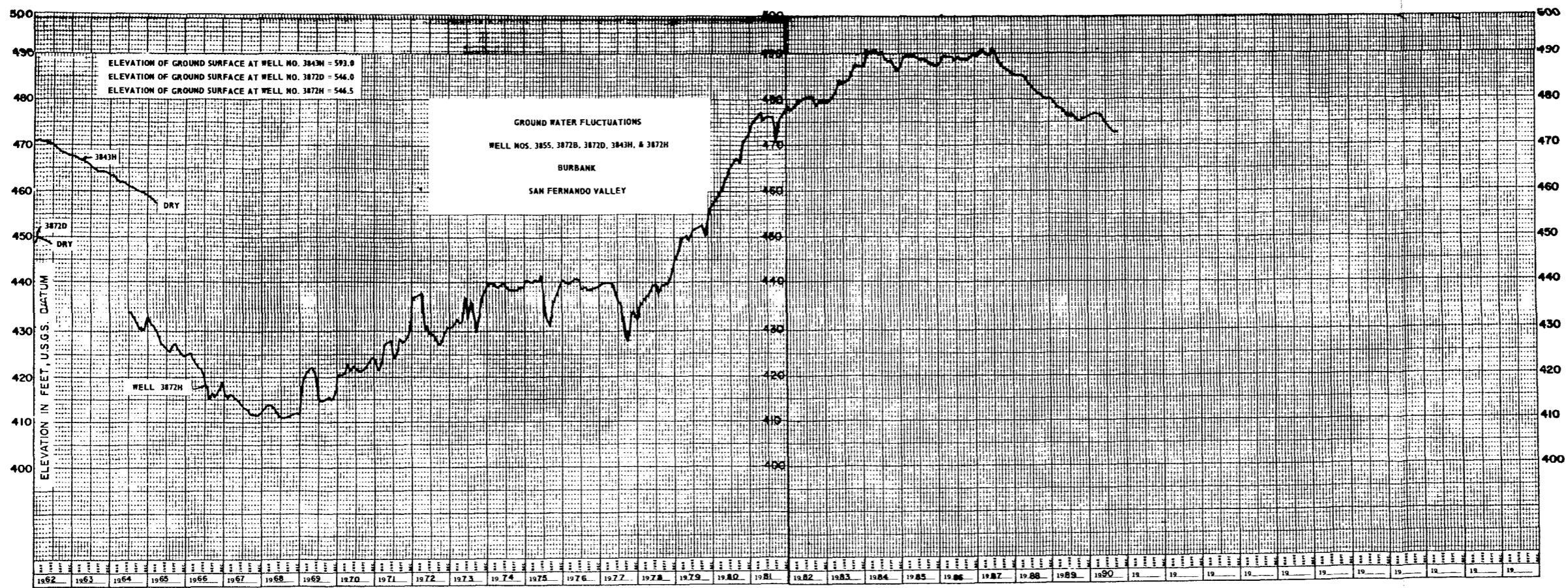
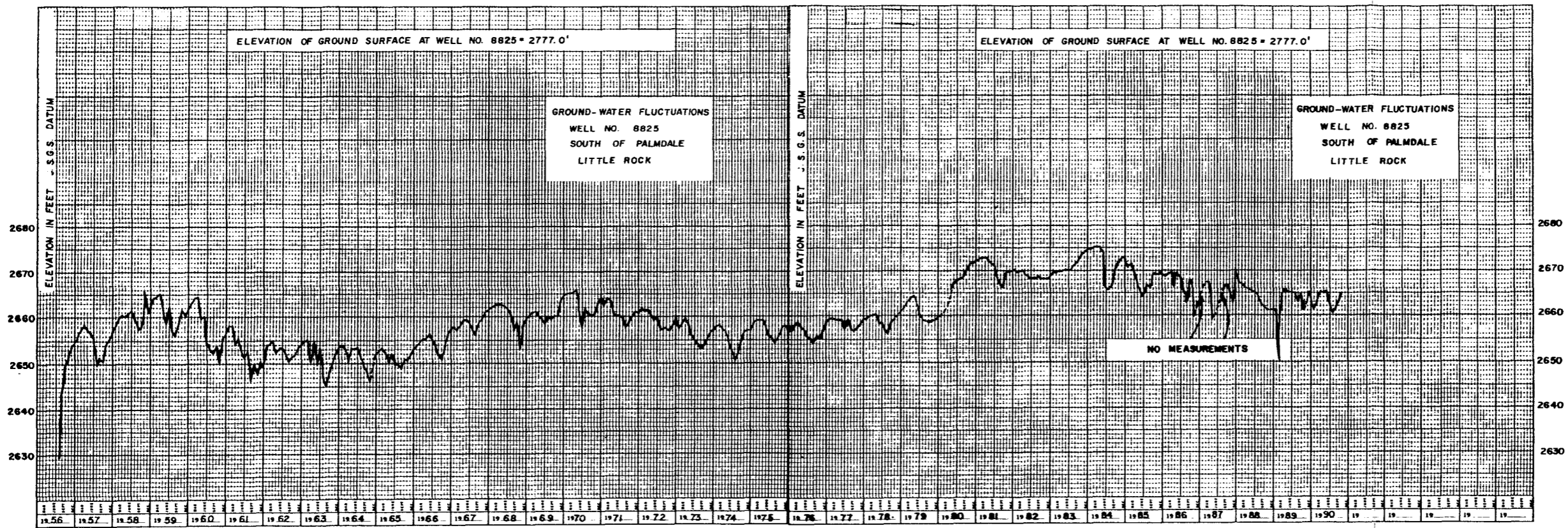

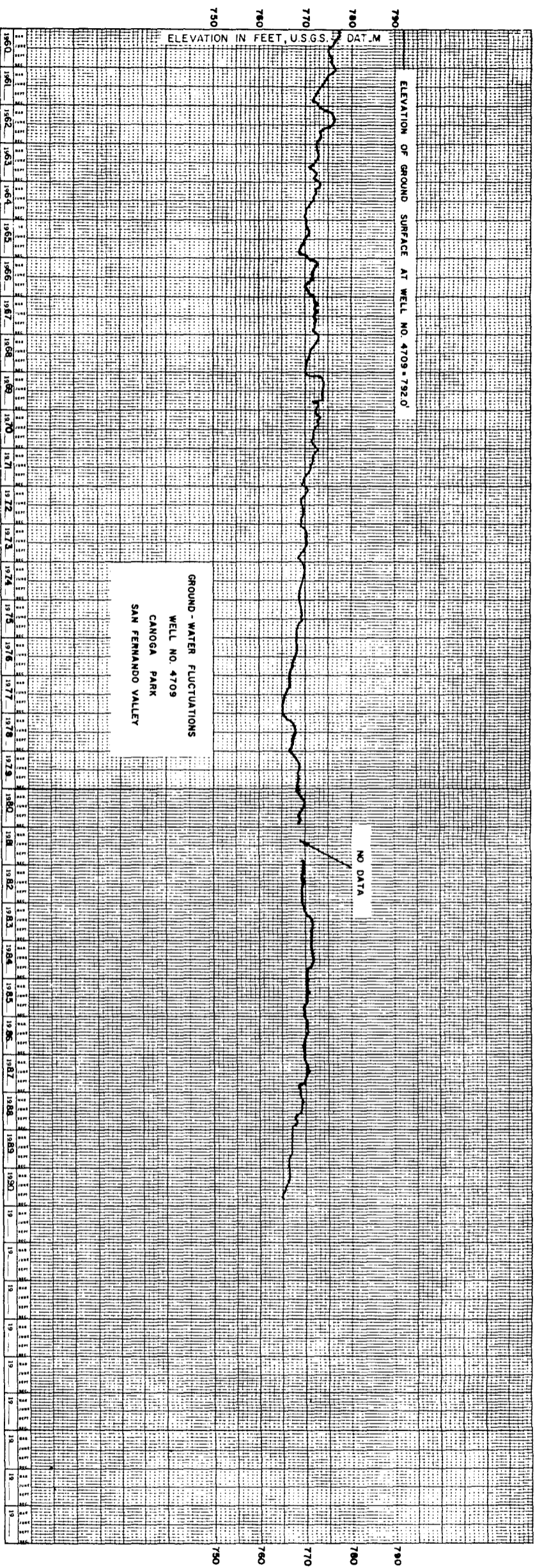

LOS ANGELES COUNTY DEPARTMENT OF PUBLIC WORKS GROUNDWATER BASINS AND RECHARGE FACILITIES

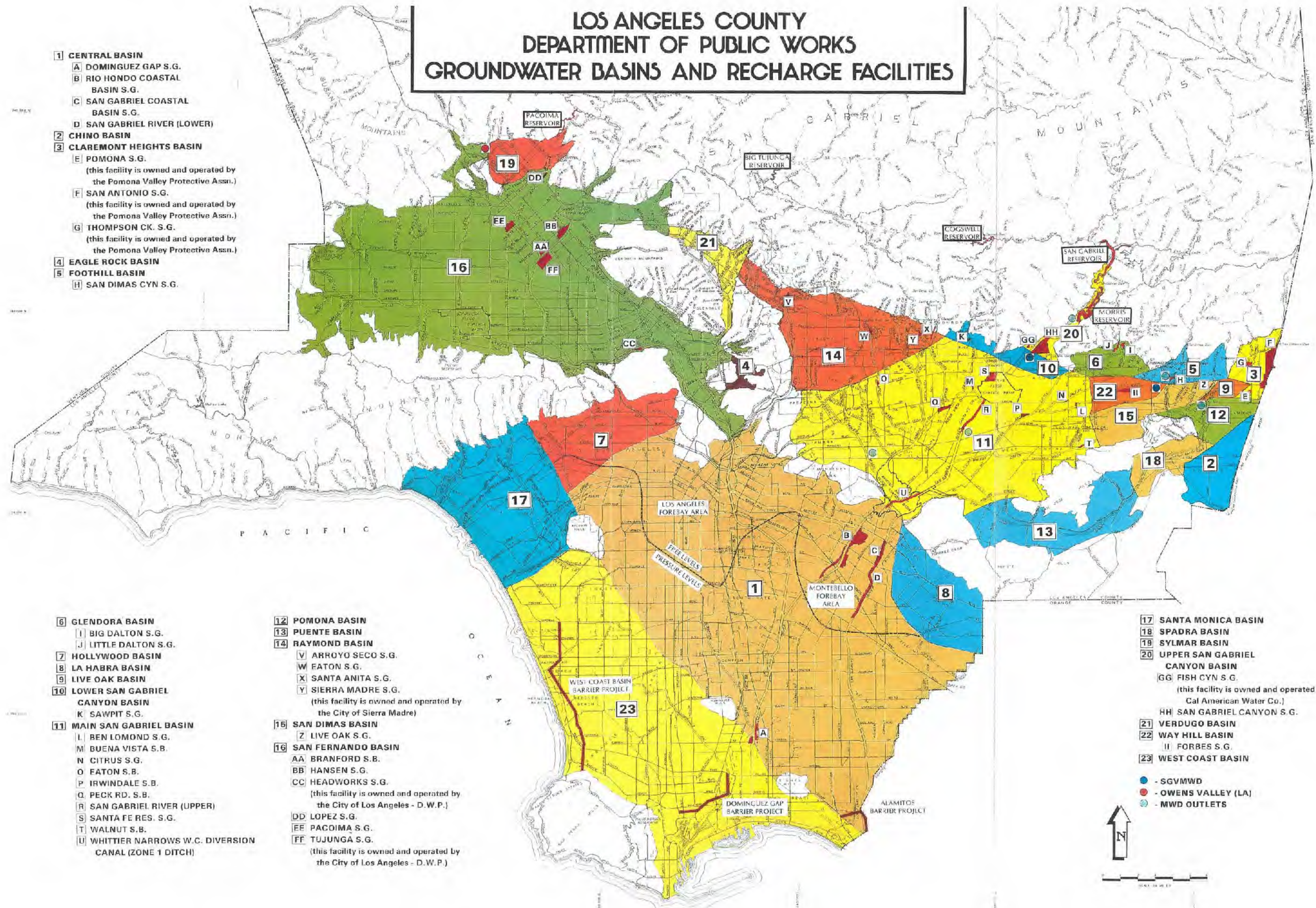

- 1 CENTRAL BASIN**
 - A DOMINGUEZ GAP S.G.
 - B RIO HONDO COASTAL BASIN S.G.
 - C SAN GABRIEL COASTAL BASIN S.G.
 - D SAN GABRIEL RIVER (LOWER)
- 2 CHINO BASIN**
- 3 CLAREMONT HEIGHTS BASIN**
 - E POMONA S.G.
(this facility is owned and operated by the Pomona Valley Protective Assn.)
 - F SAN ANTONIO S.G.
(this facility is owned and operated by the Pomona Valley Protective Assn.)
 - G THOMPSON CK. S.G.
(this facility is owned and operated by the Pomona Valley Protective Assn.)
- 4 EAGLE ROCK BASIN**
- 5 FOOTHILL BASIN**
 - H SAN DIMAS CYN S.G.

- 6 GLENDORA BASIN**
 - I BIG DALTON S.G.
 - J LITTLE DALTON S.G.
- 7 HOLLYWOOD BASIN**
- 8 LA HABRA BASIN**
- 9 LIVE OAK BASIN**
- 10 LOWER SAN GABRIEL CANYON BASIN**
 - K SAWPIT S.G.
- 11 MAIN SAN GABRIEL BASIN**
 - L BEN LOMOND S.G.
 - M BUENA VISTA S.B.
 - N CITRUS S.G.
 - O EATON S.B.
 - P IRWINDALE S.B.
 - Q PECK RD. S.B.
 - R SAN GABRIEL RIVER (UPPER)
 - S SANTA FE RES. S.G.
 - T WALNUT S.B.
 - U WHITTIER NARROWS W.C. DIVERSION CANAL (ZONE 1 DITCH)

- 12 POMONA BASIN**
- 13 PUENTE BASIN**
- 14 RAYMOND BASIN**
 - V ARROYO SECO S.G.
 - W EATON S.G.
 - X SANTA ANITA S.G.
 - Y SIERRA MADRE S.G.
(this facility is owned and operated by the City of Sierra Madre)
- 15 SAN DIMAS BASIN**
 - Z LIVE OAK S.G.
- 16 SAN FERNANDO BASIN**
 - AA BRANFORD S.B.
 - BB HANSEN S.G.
 - CC HEADWORKS S.G.
(this facility is owned and operated by the City of Los Angeles - D.W.P.)
 - DD LOPEZ S.G.
 - EE PACOIMA S.G.
 - FF TUJUNGA S.G.
(this facility is owned and operated by the City of Los Angeles - D.W.P.)

- 17 SANTA MONICA BASIN**
 - 18 SPADRA BASIN**
 - 19 SYLMAR BASIN**
 - 20 UPPER SAN GABRIEL CANYON BASIN**
 - GG FISH CYN S.G.
(this facility is owned and operated by Cal American Water Co.)
 - HH SAN GABRIEL CANYON S.G.
 - 21 VERDUGO BASIN**
 - 22 WAY HILL BASIN**
 - II FORBES S.G.
 - 23 WEST COAST BASIN**
- - SGVMWD
● - OWENS VALLEY (LA)
● - MWD OUTLETS

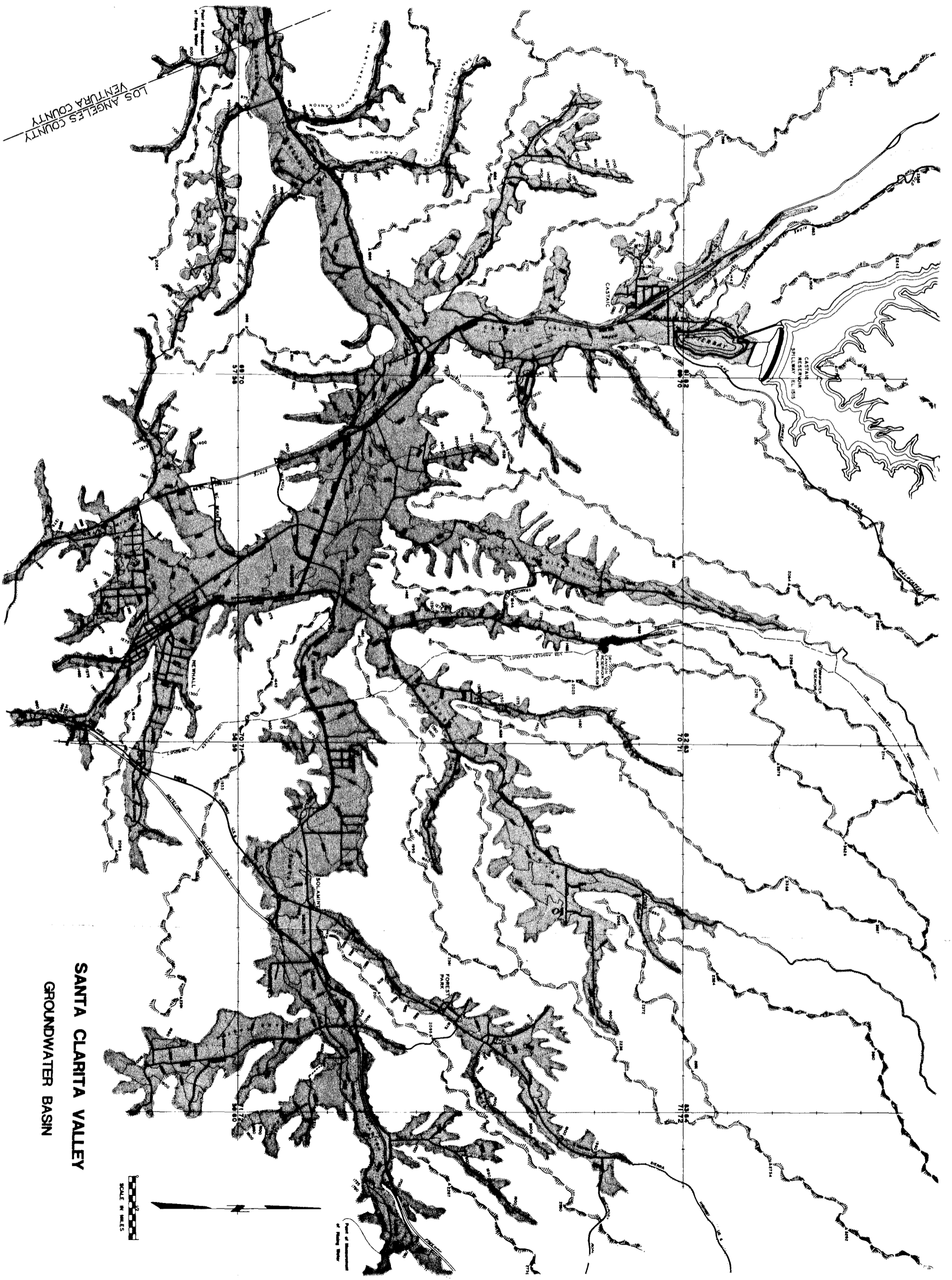

LOS ANGELES COUNTY
VENTURA COUNTY

**SANTA CLARITA VALLEY
GROUNDWATER BASIN**



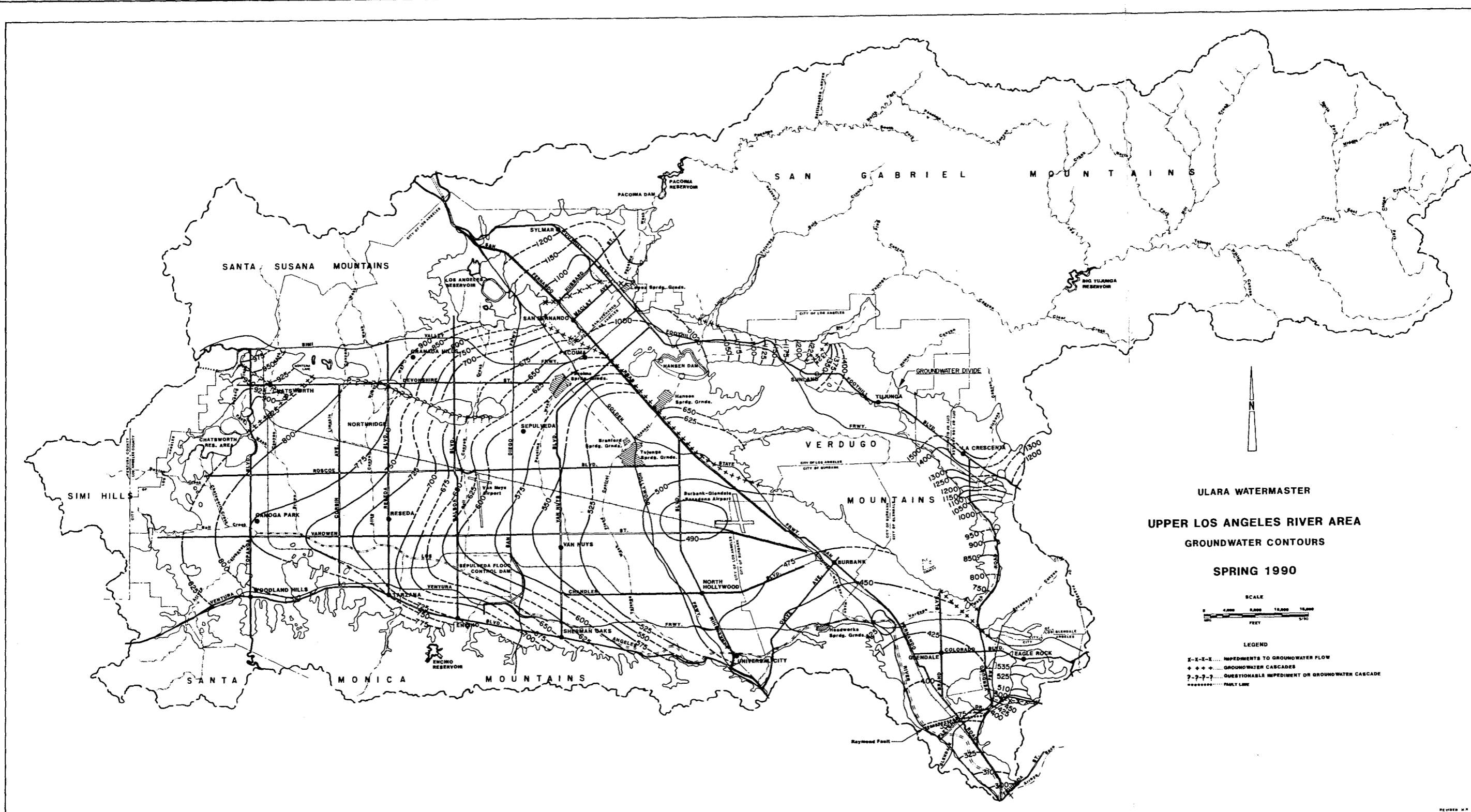

ULARA WATERMASTER
 UPPER LOS ANGELES RIVER AREA
 GROUNDWATER CONTOURS
 SPRING 1990

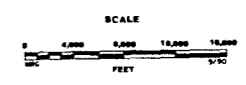

- LEGEND
- - - - - IMPEDIMENTS TO GROUNDWATER FLOW
 - + + + + + GROUNDWATER CASCADES
 - ? - ? - ? QUESTIONABLE IMPEDIMENT OR GROUNDWATER CASCADE
 - FAULT LINE

REVISED BY M. BACIA 1988

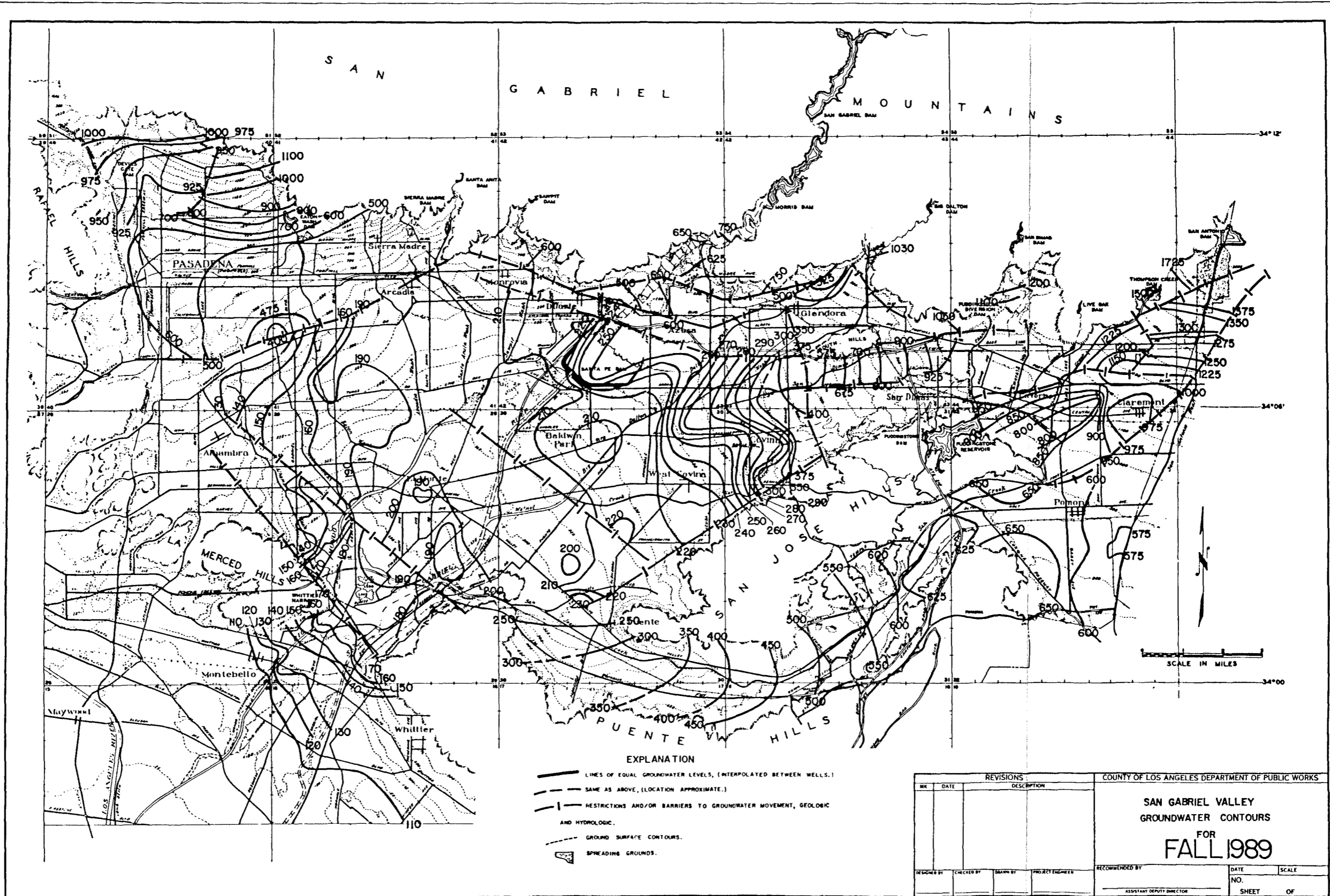

- EXPLANATION
- LINES OF EQUAL GROUNDWATER LEVELS, (INTERPOLATED BETWEEN WELLS.)
 - - - SAME AS ABOVE, (LOCATION APPROXIMATE.)
 - |— RESTRICTIONS AND/OR BARRIERS TO GROUNDWATER MOVEMENT, GEOLOGIC AND HYDROLOGIC.
 - - - GROUND SURFACE CONTOURS.
 - ◻ SPREADING GROUNDS.

REVISIONS				COUNTY OF LOS ANGELES DEPARTMENT OF PUBLIC WORKS	
NO.	DATE	BY	DESCRIPTION	DATE	SCALE
DESIGNED BY	CHECKED BY	DRAWN BY	PROJECT ENGINEER	RECOMMENDED BY	DATE
				ASSISTANT DEPUTY DIRECTOR	SHEET OF

SAN GABRIEL VALLEY
GROUNDWATER CONTOURS
FOR
FALL 1989

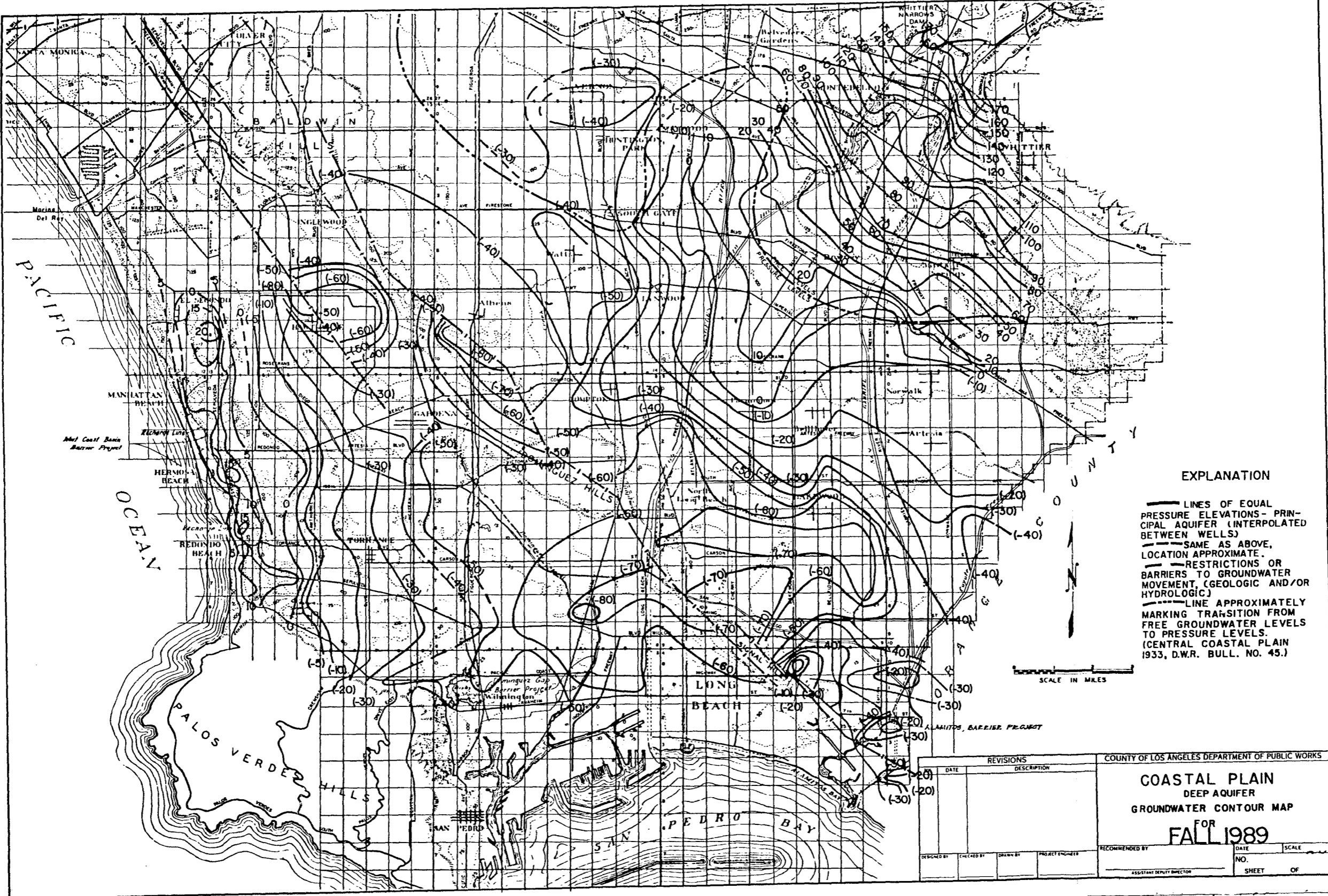

EXPLANATION

- LINES OF EQUAL PRESSURE ELEVATIONS - PRINCIPAL AQUIFER (INTERPOLATED BETWEEN WELLS)
- - - SAME AS ABOVE, LOCATION APPROXIMATE.
- RESTRICTIONS OR BARRIERS TO GROUNDWATER MOVEMENT (GEOLOGIC AND/OR HYDROLOGIC)
- - - LINE APPROXIMATELY MARKING TRANSITION FROM FREE GROUNDWATER LEVELS TO PRESSURE LEVELS. (CENTRAL COASTAL PLAIN 1933, D.W.R. BULL. NO. 45.)

SCALE IN MILES

REVISIONS				COUNTY OF LOS ANGELES DEPARTMENT OF PUBLIC WORKS	
DATE	DESCRIPTION	DESIGNED BY	CHECKED BY	PROJECT ENGINEER	RECOMMENDED BY

**COASTAL PLAIN
DEEP AQUIFER
GROUNDWATER CONTOUR MAP
FOR
FALL 1989**

DATE _____ SCALE _____
NO. _____ SHEET _____ OF _____

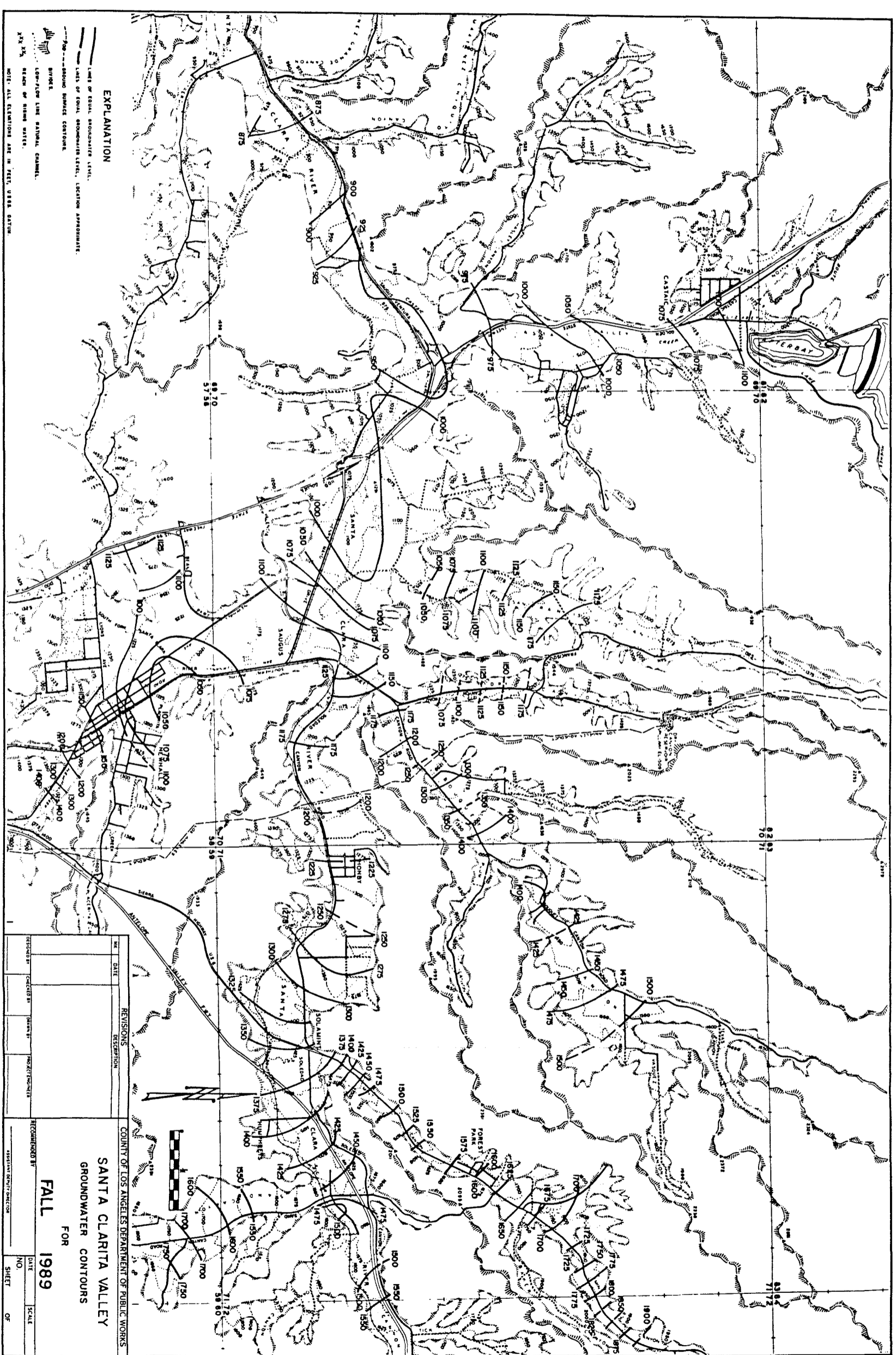

EXPLANATION

———— LINE OF EQUAL GROUNDWATER LEVEL.

———— LINE OF EQUAL ELEVATION LEVEL, LOCATION APPROXIMATE.

--- --- SHOWN SURFACE CONTOUR.

--- --- RIVER.

--- --- LOW-FLOOR LINE NATURAL CHANNEL.

--- --- REACH OF RIVER WATER.

NOTE: ALL ELEVATIONS ARE IN FEET, U.S. SYSTEM.

NO.	DATE	REVISIONS DESCRIPTION

COUNTY OF LOS ANGELES DEPARTMENT OF PUBLIC WORKS

**SANTA CLARITA VALLEY
GROUNDWATER CONTOURS**

FALL 1989

FOR

DESIGNED BY		REVISIONS BY	
CHECKED BY		DATE	
DRAWN BY		NO. OF SHEETS	
PROJECT		NO. OF SHEETS	

DATE: _____

SCALE: _____

SHEET NO. _____ OF _____